



# HENDI

Tools for chefs | 2019



RABY HUNT



# HENDI TERMÉKKATALÓGUS 2019

**Forgalmazó:**

  
VENDI HUNGÁRIA Kft.

[www.vendi.hu](http://www.vendi.hu)

1106 Budapest, Tündérfürt u. 2. — + 36 1 / 431-8687 — [tervezes@vendi.hu](mailto:tervezes@vendi.hu)  
7100 Szekszárd, Rákóczi u. 164. — + 36 74 / 510-054 — [info@vendi.hu](mailto:info@vendi.hu)



On the cover: James Close from 2-star restaurant Raby Hunt (UK)

# Entering the Michelin guide with



**After James Close gave up on becoming a pro golfer, he took a year off to travel France. This experience eventually changed his life. After arriving back in the UK, he started working towards his new goal; becoming a chef. A decade later he's the proud chef and owner of Raby Hunt Restaurant, which received its second Michelin star in 2017 and what is equally remarkable is that he achieved this, completely self-taught.**

James Close's restaurant 'Raby Hunt' is located near Darlington in North East England. In his recently remodelled kitchen he works together with his partner Maria and his team of 8 chefs. James thanks his success to hard work and the mindset of an athlete. We met him for a small interview.

#### **Ambition**

"My goal has always been to improve myself, not on getting rewards. This is a mindset I took with me from my time as 'failing' pro golfer. When I'm cooking,

# an athlete's mindset.



**Being consistent every time you cook, that's the real challenge.**

I always want to learn and improve myself. No dish goes on the menu before it's absolutely perfect."

### Consistency

"Although I love nothing more than creating new dishes and playing with new flavours and techniques, I also appreciate the daily routine of the kitchen, something lots of young chefs seem to have a different opinion on. The repetition of getting the dishes to the same level of quality as the day before seems boring, but for me therein lies the real challenge. Guests

expect to receive the same flavours and experience as other guests before them and I see it as my main task to deliver or even exceed their expectations. That's why some dishes have been on the menu for several years, I still feel challenged preparing them and guests are still surprised by them."

### Hendi items James uses

- Multiple sous-vide systems
- Pots & pans
- GN-sized storage containers







# HENDI

FOOD SERVICE EQUIPMENT

Hendi Food Service Equipment is the supplier and manufacturer of non-food catering equipment, buffet products, kitchenware and tableware for the hospitality and catering industry. Since our foundation in 1934, Hendi has experienced continuous growth and is now an international company with warehouses in the Netherlands, Austria, Poland, United Kingdom, Romania and Greece.

In addition, we have our own salespeople in key European countries, such as Germany, France and Italy.



#### ■ Hendi BV

Steenoven 21, 3911 TX Rhenen  
The Netherlands  
T: +31 (0)317 68 10 40  
F: +31 (0)317 68 10 45  
info@hendi.eu, www.hendi.eu

#### ■ Hendi Polska Sp. z o.o.

ul. Magazynowa 5, 62-023 Gądk  
Poland  
T: +48 61 658 70 00  
F: +48 61 658 70 01  
info@hendi.pl, www.hendi.pl

#### ■ Hendi Food Service Equipment GmbH

Gewerbegebiet Ehring 15  
5112 Lamprechtshausen, Austria  
T: +43 (6274) 200 10 0  
F: +43 (6274) 200 10 20  
office.austria@hendi.eu, www.hendi.eu

#### ■ Hendi UK Ltd.

Central Barn, Hornby Road  
Lancaster, LA2 9JX  
United Kingdom  
T: +44 (0) 333 0143200  
sales@hendi.co.uk, www.hendi.co.uk

#### ■ Hendi Food Service Equipment Romania S.R.L.

Str. 13 decembrie 94A, Hala 14  
Braşov 500164 RO  
Romania  
T: +40 268 320330  
F: +40 268 320335  
office@hendi.ro, www.hendi.eu

#### ■ PKS Hendi South East Europe SA

5 Metsovou Str.  
18346 Moschato, Athens  
Greece  
T: +30 210 483 97 00  
F: +30 210 483 97 10  
office.greece@hendi.eu, www.hendi.eu

#### ■ Hendi Italia S.R.L.

Boznerstrasse 63 - Via Bolzano, 63  
39057 Eppan a.d.W.-Appiano s.s.d.v.(BZ)  
Italy  
T: +39 471 918 656  
F: +39 471 505 566  
office.italy@hendi.eu, www.hendi.eu

#### ■ Hendi HK Ltd.

1208, 12/F, Exchange Tower  
33 Wang Chiu Road, Kowloon Bay  
Hong Kong  
info-hk@hendi.eu  
www.hendi.eu

POTS & PANS

GN CONTAINERS

KITCHEN TOOLS

CREAM WHIPPERS & PASTRY

FOOD PROCESSING

THERMAL PROCESSING

PIZZA, PASTA & KEBAB

CONVECTION OVENS

COOLING

TRANSPORT & FURNITURE

HYGIENE

BAR & COLD DRINKS

HOT DRINKS

TABLEWARE

BUFFET PRODUCTS

BARBECUES & HEATERS



2



11



13



14



15



16



20



26



28



29



30



32



36



40



58



66



80



88



98



102

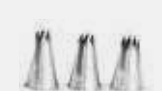

109



110



114



115



118



122



126



132



134



137



143



146



154



165



170



174



186



188



190



191



194



195



196



198



200



202



204



206



211



221



222



225



227



232



234



236



237



246



248



249



250



252



254



257



259



259



262



266



268



281



284



286



288



290



292



296



297



297



298



304



330



332



335



342



344



356



360



365



370



393



398



403



404



405



406



409



# Selection of new products for 2019

<p><b>POTS &amp; PANS</b></p> <p><b>Griddle for induction cookers</b> page 10</p> 	<p><b>POTS &amp; PANS</b></p> <p><b>Fish poacher 60cm</b> page 15</p> 	<p><b>GN CONTAINERS</b></p> <p><b>Grilamid GN container for high temperatures</b> page 27</p> 
<p><b>KITCHEN TOOLS</b></p> <p><b>Cutting board HACCP Gastronorm 1/1</b> page 38</p> 	<p><b>KITCHEN TOOLS</b></p> <p><b>9-piece Knives set</b> page 44</p> 	<p><b>KITCHEN TOOLS</b></p> <p><b>Cut resistant gloves</b> page 53</p> 
<p><b>KITCHEN TOOLS</b></p> <p><b>Colander square perforated</b> page 85</p> 	<p><b>KITCHEN TOOLS</b></p> <p><b>Kitchen scale 15 kg</b> page 87</p> 	<p><b>KITCHEN TOOLS</b></p> <p><b>Smoke Infuser</b> page 97</p> 
<p><b>BAKERY &amp; PASTRY</b></p> <p><b>Thermo Cream Whipper</b> page 99</p> 	<p><b>BAKERY &amp; PASTRY</b></p> <p><b>Icing tips set flower &amp; petal</b> page 109</p> 	<p><b>BAKERY &amp; PASTRY</b></p> <p><b>5 Wheel dough cutter</b> page 112</p> 

## FOOD PROCESSING

**Stick blender Profi Line 400 with adjustable speed**  
page 122



## FOOD PROCESSING

**Vacuum chamber packaging machine Profi Line**  
page 138



## THERMAL PROCESSING

**Gas cooker Kitchen Line 4-burner with convection electric oven GN 1/1**  
page 144



## THERMAL PROCESSING

**Quartz heated countertop display two levels**  
page 151



## THERMAL PROCESSING

**Rise and fall heat lamp**  
page 153



## THERMAL PROCESSING

**iVide Plus Sous vide stick**  
page 156



## THERMAL PROCESSING

**Smoke oven electric**  
page 159



## THERMAL PROCESSING

**The Control °Freak™ Induction Hob**  
page 161



## THERMAL PROCESSING

**Food dehydrator Profi Line**  
page 163



## THERMAL PROCESSING

**Deep fryers mastercook digital**  
page 164



## THERMAL PROCESSING

**Doughnut deep fryer 12L**  
page 169



## THERMAL PROCESSING

**Salamander with Quartz infrared heating elements**  
page 175



# Selection of new products for 2019

## THERMAL PROCESSING

**Multi Toaster 6 tongs**  
page 181



## THERMAL PROCESSING

**Samsung microwave programmable 1780W**  
page 182



## PIZZA, PASTA & KEBAB

**Spiral mixers**  
page 188



## CONVECTION OVENS

**Convection ovens & combi-ovens  
NANO 4x 450x340mm**  
page 200



## CONVECTION OVENS

**Oven mitts leather**  
page 209



## COOLING

**Round cake display 100L**  
page 210



## COOLING

**Back bar refrigerators**  
page 216



## COOLING

**Wine coolers dual zone**  
page 217



## COOLING

**Ice cream display freezer 600 L**  
page 219



## COOLING

**Three door salad counter  
with glass display 380L**  
page 227



## HYGIENE

**Glass dishwasher K40**  
page 250



## HYGIENE

**Water softeners**  
page 254



**NEW!**

**HYGIENE**

**Trash bin 43 L**  
page 261



**BAR & COLD DRINKS**

**Ice ball mould whisky ball**  
page 267



**BAR & COLD DRINKS**

**Bullet ice cube maker**  
page 269



**BAR & COLD DRINKS**

**Juice dispenser 2x12L**  
page 280



**HOT DRINKS**

**Coffee tamper with spring**  
page 288



**HOT DRINKS**

**Percolator single walled**  
page 291



**HOT DRINKS**

**Hot drinks boiler**  
page 296



**TABLEWARE**

**Galvanized buckets**  
page 324



**BUFFET PRODUCTS**

**Chafing dishes Profi Line satin finish**  
page 350



**BUFFET PRODUCTS**

**Buffet ladles and serving spoons**  
page 360



**BUFFET PRODUCTS**

**Juice dispenser**  
page 370



**BUFFET PRODUCTS**

**Retractable belt barrier**  
page 377





## INDEX A-Z

### A

Adaptor bar for Gastronorm containers.....	23
Air pot.....	331
Analog kitchen timer .....	92
Anti-Griddle™.....	161
Anti-slip mat .....	38
Apple corer.....	51
Aromatic wood chips.....	160
Ashtrays and ash collector .....	339 - 340

### B

Baba mould.....	110
Back bar refrigerators.....	216, 270
Bag rolls attachment for vacuum packing machine.....	140
Baguette board .....	39, 374
Bain-marie gastronorm.....	178
Bakers' sieve.....	113
Bakery humidified convection oven.....	199
Baking mat non-stick silicone.....	113
Baking moulds.....	114
Ball measuring pourer .....	264
Bar blade.....	262
Bar caddy.....	285
Bar mat .....	286
Bar spoon.....	284
Bar storers.....	279
Bar tables.....	379
Barbecue accessories .....	400 - 402, 406 - 407
Barbecues and grills .....	398 - 399, 402 - 406
Barrier posts.....	377
Baskets .....	328, 375
Basting spoon .....	79
Beer glass carrier.....	287
Beer skimmer.....	287
Beer tray .....	397
Bird's nest shaped strainer .....	67
Blackboards.....	343
Blast chillers.....	230, 231
Blender jars .....	281
Blender with noise cover .....	282, 283
Blinis frying pan .....	14
Bombe pan.....	9
Boning knife.....	41 - 42, 45
Boston shaker.....	284
Bottle cap perforator .....	264
Bottle opener with catcher bin.....	262
Bowls .....	82, 314, 320, 388
Bread bags.....	327
Bread baskets .....	328, 375
Bread board .....	39, 374
Bread knife.....	41, 43, 45
Breadroll dispenser .....	233
Bucket miniatures.....	322
Buckets .....	65, 68, 320, 324
Buffet dishes, display stands and serving stands.....	386 - 388
Buffet ladles and serving spoons .....	360
Buffet tables.....	378, 380
Butane gas cartridge .....	145

Butcher's hooks.....	62
Butcher's knife.....	45
Butter & Sauce dish.....	325
Butter and fat brushes.....	111
Butter curler .....	51

### C

Cake displays .....	210, 211
Cake mould .....	110
Cake plates .....	367
Cake scoop/cutter/knife/server..	192, 360, 361, 367
Cake tongs .....	363
Can opener.....	56
Candle holder.....	354, 376
Cappuccino steam jug.....	332
Carafe.....	372
Carving board.....	39, 374
Carving fork .....	41, 43, 79, 360 - 361
Carving knife.....	35, 41 - 42, 45
Cast iron griddle .....	401
Catering chair .....	380
Centrifugal juice extractor.....	274
Chafing Dish fuel.....	356, 357
Chafing Dish heaters .....	347
Chafing Dish ladles and serving spoons .....	361
Chafing Dish round .....	348, 351
Chafing Dishes electric.....	346
Chafing Dishes gastronorm .....	347 - 351, 353, 356 - 357
Champagne cooler.....	266
Champagne stopper .....	264
Channel knife.....	50
Charcoal barbecues.....	406
Cheese grater, slicer and knife.....	52
Cheese-grating machine .....	187
Chef's hats .....	261
Chest freezer .....	219
Chicken grid .....	207
Children's plate.....	316
Chip scoops & shovels.....	66 - 67
Chips bag holder .....	319
Chips colanders .....	64
Chocolate fountain.....	373
Citrus juicers and squeezers.....	276 - 279
Citrus peeler .....	50
Clearing trolleys.....	234, 235
Cleaver.....	41, 43
Clips for dishwasher racks.....	253
Cloth strainer.....	68
Cocktail shaker .....	284
Coffee machines and filters.....	290
Coffee tamper .....	288
Coffee trays.....	397
Coffee/tea pot with lid.....	332
Coin tokens .....	287
Colanders .....	85, 322
Condiment sets.....	316, 334 - 335
Confectionery funnels.....	93
Conical strainers.....	83
Contact grills.....	172 - 173
Container with non-stick coating .....	208

Convection ovens.....	196, 198 - 201
Convection steam ovens.....	198, 202 - 205
Conveyor toasters .....	180
Cooking spoon .....	73
Cook's knife.....	35, 40, 42, 45
Cooling element GN 1/1.....	243, 245, 247
Cordless kebab knife electric .....	187
Corkscrews & bottle openers.....	262
Countertop cooling displays .....	213, 219
Cream jug.....	332
Cream whippers and supplies.....	98, 100 - 101
Crème-Brûlée burners.....	116, 117
Crêpes and waffle makers.....	179
Crêpes pan .....	11 - 12, 14
Cups and saucers .....	305, 307, 309, 311, 313, 320
Curved porcelain.....	389
Cut resistant gloves .....	53
Cutlery.....	298 - 303
Cutlery & napkin caddy.....	324
Cutlery trays, stand, baskets and holder....	253, 381
Cutting boards .....	35 - 39, 285, 374

### D

Dariole moulds.....	110
Decanter.....	290
Decorating and injector tips .....	99
Decoration tools.....	51, 52
Deep fryers Mastercook and Blue Line....	164 - 166
Deep frying basket miniatures .....	318
Deep plates .....	305, 307, 309, 311, 313, 320
Dicing disc.....	119
Digital kitchen timer .....	92
Digital scale .....	87
Dish warmers.....	354
Dishwasher baskets and racks.....	252 - 253
Dishwashers .....	250
Dispenser bottles.....	94 - 95
Dispensers and jugs .....	370
Display refrigerators.....	211, 218
Display trays.....	232 - 233
Door signs .....	341
Dough cutters & scrapers .....	51, 112
Dough docker .....	115
Doughnut deep fryer.....	169
Drainage mat .....	286
Drawer with rails .....	224
Dressing- and panwhisk .....	80
Dressing pot.....	390
Dripping tray .....	26, 29
Dutch pancake griddle.....	400

### E

Egg cup and spoon.....	337
Egg slicers .....	56
Electric dough rollers .....	191
Electric kettles .....	69, 297
Electric meat tenderizer.....	125
Electric soup kettles .....	344
Embossed vacuum bags .....	140 - 141, 156
Enamelled pans .....	17, 320 - 321, 402

Extender for dishwasher basket.....252

## F

Fast food trays..... 391 - 392  
Fast response thermometer..... 91  
Fat skimmer..... 67  
Filleting knife..... 45  
Fish bone tweezers..... 72  
Fish frying pan..... 11-12  
Fish poacher..... 15  
Flat plate..... 305, 307, 309, 311, 313, 320  
Floor stand ovens..... 198 - 199  
Foldable catering furniture..... 378  
Folding chair cover..... 380  
Folding tray stand..... 394  
Fondue-burner..... 357  
Food dehydrators..... 162 - 163  
Food rings and pushers..... 96, 110  
Forage hats..... 261  
Free-flow pourer..... 263  
Freezer counters..... 223 - 224  
Freezers..... 220 - 221  
French fries cutter..... 61, 120  
French fries cutting disc..... 119  
French whisks..... 80  
Fruit basket..... 328  
Frying pans..... 5, 7, 11 - 14, 17  
Fuel dispenser..... 357  
Fuel for fondue-burners..... 357  
Funnels..... 69, 99

## G

Galvanized buckets and tubs..... 324  
Garlic press..... 56  
Garnish bowl slanted..... 314, 318  
Garnishing tools..... 52  
Gas canister..... 117  
Gas cookers..... 143 - 145  
Gas lighter..... 117  
Gastronorm containers..... 20 - 31  
Gastronorm containers enamelled..... 208  
Gastronorm grids..... 207  
Gastronorm lids..... 21, 23, 25 - 31, 33, 35  
Gastronorm pans porcelain..... 390  
Gastronorm perforated inserts..... 23  
Gastronorm trays..... 207, 385  
Glass brushes..... 286  
Glass dishwasher..... 250  
Glass dome..... 97, 160  
Glass rimmer..... 285  
Gourmet pan..... 15  
Grapefruit knife..... 50  
Grater, four-sided..... 58  
Grating disc..... 118  
Gravy boat..... 316  
Gravy pan..... 16  
Grease filter for deep fryer..... 65  
Greaseproof paper..... 319  
Grid & flame tamer..... 401  
Grid for ovens..... 206

Griddle for induction cookers..... 10  
Griddle scrapers..... 74, 170, 406  
Griddles Blue Line..... 170  
Grill mesh non-stick PTFE..... 162  
Grill pan - ridged surface..... 11  
Group head cleaning brush..... 289

## H

HACCP Cutting mat set..... 38  
HACCP Kitchen knives..... 35, 45 - 49  
HACCP Storage containers..... 32 - 34  
Ham/salmon knife..... 41, 43, 45  
Hamburger press..... 131  
Hamburger turner..... 74  
Hand dryer..... 259  
Heated countertop cabinets and displays.. 151, 152  
Heating element GN 1/1..... 243 - 244  
Heavy duty mixers..... 124  
High power blender..... 281  
High voltage insect killer..... 258  
Hokkers..... 142  
Honey dispenser..... 334  
Hood dishwasher..... 251  
Horeca markers..... 33  
Hot Chocolate dispenser..... 297  
Hot drinks boilers..... 294 - 296  
Hot tray..... 151  
Hotdog stand..... 94  
Humidified convection oven..... 197

## I

Ice bucket double-walled..... 266  
Ice cream bowl „Clown“..... 316  
Ice cream cones stand..... 105  
Ice cream containers and lids..... 106  
Ice cream dippers, scoops and spatulas.. 102 - 105  
Ice cream display freezer..... 219  
Ice cream maker..... 107  
Ice crushers..... 272  
Ice cube tongs..... 266  
Ice flakes maker..... 269  
Ice moulds and machines..... 267 - 268  
Ice scoop..... 266  
Ice-cream cup..... 337  
Icing tips and tubes..... 109  
Induction cookers..... 146 - 150  
Induction deep fryer..... 168  
Induction frying pan..... 10  
Induction heater..... 151, 347  
Induction hot plate..... 147  
Induction wok..... 148  
Infrared food warmer bridge..... 153  
Infrared heat bulb..... 153  
Infrared thermometers..... 90  
Ingredient box..... 285  
Ingredient trolley..... 240  
Insect killers..... 256 - 258  
Insulated catering containers  
and dispensers..... 242, 248  
Insulated ice container..... 241

iVide Sous Vide circulators..... 155 - 156

## J

Japanese knives..... 44  
Jigger..... 284  
Juice dispensers..... 280, 370 - 371  
Juice jug..... 372

## K

Kebab grill & knives..... 186 - 187  
Kitchen bowl..... 82  
Kitchen scale..... 87  
Kitchen scissors..... 53  
Kitchen sink..... 259  
Kitchen spoon..... 77  
Knife magnet with hooks..... 43  
Knife sharpeners..... 41, 43, 45, 54  
Knives..... 35, 40 - 49, 126 - 129  
Knives carrying case..... 53  
Knock boxes..... 289

## L

Ladles and skimmers..... 78 - 79  
Ladles, turners and serving spoons  
- heat resistant..... 73, 362  
Large digital scale..... 87  
Lava rocks and rock grid..... 401 - 402  
Lemon slice squeezer..... 333  
Lemon Zester..... 50  
Lid clips for HACCP storage containers..... 33, 35  
Lid for bucket with reinforced base..... 68  
Lid for pizza dough boxes..... 192  
Lid for racks..... 253  
Lid spacer for pizza's..... 194  
Liquid chafing dish fuel with wick..... 358 - 359  
Loading table with sink for dishwasher..... 251  
Lobster forks and tongs..... 303  
Lounge Heater..... 409  
Low temperature oven..... 157

## M

Measuring jugs..... 86  
Meat & chips tray..... 64  
Meat mincers..... 126 - 130  
Meat slicers..... 134  
Meat Tenderizers..... 63  
Meat tray..... 232 - 233  
Melamine..... 382, 384, 386, 387, 395  
Melon scoops..... 50  
Menu card table stand..... 338  
Microwaves..... 182 - 185  
Milk dispenser..... 371  
Milk frothing thermometer..... 92, 289  
Milk jug..... 316, 332  
Milkshaker..... 278  
Mincing knives & scissors..... 53  
Mini pans Little Chef..... 326  
Mixing bowl with rounded base..... 82  
Muddler..... 284  
Mug..... 309, 320  
Multi dispenser..... 371

Multi rack	289, 376
Multi Toaster 6 tongs	181
Multipurpose jugs	332
Multipurpose tweezers	72
Mussel & gravy pans	16

## N

Napkin holder	337
Non-drip pourers and brackets	264
Non-slip display stands	388
Non-stick baking mats, grids & paper	113
Non-stick coated blade for slicers	135

## O

Oil and vinegar set	334
Oil jug	69
Onion goggles	57
Oval dish	305, 307, 309, 311, 313
Oven dishes	315
Oven mitts	209, 407
Oven thermometer	92
Oven trays	206 - 207

## P

Paella pan	17, 405
Palette knife	75
Palm tamper adjustable	288
Pan carrier adapter	7
Pan gripper	192
Pan series aluminium Profi Line	9
Pan series Budget Line	8
Pan series Kitchen Line	6
Pan series Profi Line	2, 4
Paper bags	327
Paring knives	41, 43, 49
Party pan	171
Party tray	397
Party tub	266, 324
Pasta bowl round	387
Pasta cooker basket	3
Pasta makers	190
Pasta plate	311, 313
Pastry bags	108
Pastry cutter set	111
Pastry tong	363
Patio Heaters	408 - 409
Patty dividers	131
Pavement blackboard	342
Peelers	49
Pepper and salt mills	336
Percolators	291 - 293
Perforated plate	126 - 129
Piano whisk	81
Pitchers	372
Pitta bread baskets	328
Pizza counters	228 - 229
Pizza delivery bags	194
Pizza ovens	193 - 195
Pizza preparation counters	228
Pizza preparation, baking and delivery products	192 - 194

Pizza slicer	51, 192
Planetary mixers	124
Plate square	387
Plate trolley	241
Plateaus with slate or wood appearance	382 - 383
Platform trolley	236
Platter rectangular	387
Pocket thermometers	91
Polyethylene butcher block	62
PolyScience® Chef Series sous vide thermal circulator	155
Porcelain GN pans	390
Porcelain series	305 - 315
Portable gas stove	145
Potato mashers and ricer	55
Potato peelers	51, 120
Poultry shears	43, 53
Pourers	263
Presentation displays and covers	364, 366
Presentation plates and bowls	314
Protective covers for barbecues and patio heaters	400, 402, 408 - 409

## Q

Quartz heated countertop display two levels	151
---	-----

## R

Rack for 18 vegetable cutter discs	119
Ramekin	117, 325
Raspings disc	118
Rasps	58
Reception bell	337
Refrigerated countertop serveries	225
Refrigerated display cabinets	212, 214 - 215
Refrigerator & freezer counters	222 - 224
Refrigerator thermometer	92
Refrigerators & freezers	220 - 221, 232
Replacement lamps for fly killers	257, 258
Retractable belt barrier	377
Rice cookers	158
Rice steamer basket	9
Ring for Hokker	142
Rise and fall heat lamps	153
Roasting pan	15
Roasting shovel	73
Roasting thermometer/timer	90
Roll top chafing dishes	355
Roll top displays and presentation covers	364 - 366
Roll top set	367
Rollers for electric meat tenderizer	125
Rolling pin	115
Roulade string	62
Round cake displays	210

## S

Sage Commercial by Polyscience®	161
Salad bowls	305, 307, 309, 313, 320, 369
Salad counters	226 - 227
Salad cutlery	360, 362
Salad dish	311
Salad spinner	57

Salad tongs	71, 363
Salamanders	174 - 175
Salt and pepper shakers	65, 335
Salt mills	336
Salt tablets for water softening	254 - 255
Samsung microwaves	182 - 183
Sandwich toaster	181
Santoku knife	41
Sauce boat	329
Sauce spoons and ladles	360, 362
Sauce stand	95
Saucepans	4, 7, 9
Sausage cutters	64, 130
Sausage filling machines	132
Sausage rolling grills	176
Sausage warmer	177
Sauté pan	5, 7, 11
Scales	87
Scoops	86
Scrapers & Turners	74
Sea food tray stand	369
Serving dishes	337
Serving spoons	360 - 361
Serving stands	368
Serving tongs	70 - 71, 363
Serving trays	392 - 397
Serving trolleys	235 - 236, 240
Shakers	334
Shock proof thermometer with probe	91
Side table for Green Fire barbecues	400
Side top for Xenon-Pro	404
Sieves	84
Silicone baking moulds	114
Single Pedestal Pre-Rinser	260
Skimmers	73, 78 - 79, 360 - 361
Slanted bowls	389
Slate plateaus	327
Slicers	133 - 136
Slicing disc	118
Slotted spatulas	79, 360 - 361
Slotted spoon	360
Slowjuicer	275
Slush machine	280
Small frying pan	323
Small sauce pan with spout	323
Smoking and smoke infusion	97, 159 - 160
Snack containers	322
Snail dish, tongs and fork	303
Soda siphons, chargers and accessories	273
Soup & gravy pans	16, 321
Soup and sauce bowls	329
Soup bowls	305, 307, 309, 311, 313 - 314, 329
Soup chafing dishes	348, 353
Soup kettles	344 - 345
Soup ladles	73, 360 - 361
Soup tureen	329
Sous-vide systems	154
Spaghetti spoon	73, 360 - 361
Spaghetti tongs	363
Spatula	73, 75, 77, 79

Speed peeler .....	49
Spiral mixers .....	188 - 189
Spoon holder .....	361
Spreader .....	51
Steak cutlery .....	302
Steak thermometer .....	91
Steam convection oven .....	199
Steamer for dumplings, rice and pasta .....	9
Stew pans .....	2 - 9
Stick Blenders .....	121 - 123
Storage containers Gastronorm .....	32 - 34
Storage rack .....	238, 239
Storage racks .....	237, 239
Strainer miniatures .....	322
Strainers .....	284
Sugar serving supplies .....	333 - 334
Sushi display .....	213
Sushi tweezers .....	72

**T**

Tab grabber .....	56, 338
Tab holder .....	338
Table beer tap .....	287
Table covers .....	378, 380
Table knife .....	299
Table signs .....	341
Tablecloth clip .....	337
Tabletop blackboard .....	343
Tabletop litterbin .....	338
Tamping supplies .....	288
Tap with pull out rinser .....	260
Tapas dishes .....	315 - 317
Tea service supplies .....	333
Tepan-Yaki griddle .....	171

The Control Freak™ Induction Hob .....	161
Thermo catering boxes and containers .....	243 - 245
Thermo Cream Whipper .....	99
Thermoboxes .....	246, 247
Thermometer with foldable probe .....	90
Thermosystems .....	178
Thermo-tray rectangular .....	364
Tiered stand .....	368
Toasters .....	180
Tomato cutter .....	60
Tomato knives .....	49, 51
Toothpick holder .....	334
Tortilla press .....	131
Tote box .....	253
Trash bins and bag holders .....	261
Tray Stainless steel .....	396
Trolley for dishwasher racks .....	253
Trolley for thermo container .....	243
Tumbler .....	320
Turners .....	73 - 74
Tweezers .....	72

**U**

Universal knives .....	35, 45
Universal tongs .....	72
Unloading table for dishwashers .....	251
Utility knife .....	40
UV sterilizer .....	259

**V**

Vacuum cooking bags .....	137, 154
Vacuum jugs .....	330 - 331
Vacuum packing .....	137 - 141
Vegetable corer .....	50

Vegetable cutters .....	59, 118 - 119
Vegetable dish .....	329
Vegetable spoon .....	79
Vegetable strainer .....	82
Velocity slanted bowls .....	325

**W**

Waffle makers .....	179
Waiter's corkscrews .....	262
Wall blackboard .....	342
Wall rack for pastry bags .....	108
Wall shelf .....	249
Wall signs .....	341
Washbasin knee operated .....	259
Water kettle .....	69
Water softeners .....	254-255
Waterproof thermometer .....	91
Wet floor sign .....	258
Whisk attachment for stick blenders .....	121, 123
Whisks .....	80
Wine cooler miniatures .....	322
Wine coolers .....	217, 265, 271
Wire brush .....	406
Wok .....	12, 15, 142, 148, 400
Wok holder .....	400
Wooden butcher block .....	62
Wooden rolling pin .....	115
Wooden spoon .....	77
Work table .....	249
Worm screw .....	126 - 129

**X**

Xenon & Xantos .....	404
----------------------	-----











## PAN SERIES PROFI LINE

- Sanded pan with high gloss polished heavy bumper.
- Solid handles with multi-point fixing to the pot surface which don't get hot.
- Acid-resistant.
- Sandwich type bottom (stainless steel/aluminium/stainless steel) combines the heat distribution of aluminium with the durability and magnetic properties of stainless steel to allow induction cooking.
- The bottom is formed by special impact bonding, causing the whole surface of the component layers to weld seamlessly - this guarantees corrosion resistance and optimal heat conduction.
- All lids are made of 1 mm stainless steel with steam release holes.

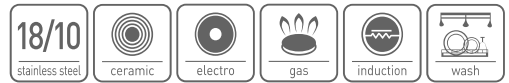

See movie

Aesthetic, solid packaging, clear and visible label



### STEW PAN HIGH - WITH LID

code	liter	wall (mm)	mm
832004	3	0,7	Ø160x(H)150
832202	6	0,7	Ø200x(H)190
832400	10	0,7	Ø240x(H)220
832509	16	0,7	Ø280x(H)260
832608	24	0,8	Ø320x(H)300
832707	37	1	Ø360x(H)360
832806	50	1	Ø400x(H)400

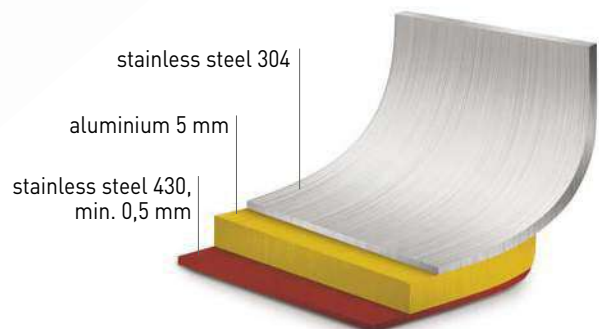



Steam release holes



Handles don't get hot



Sandwich type bottom formed by special impact bonding



**STEW PAN MIDDLE - WITH LID**

code	liter	wall (mm)	mm
831007	2	0,7	Ø160x(H)110
831205	4	0,7	Ø200x(H)130
831403	7	0,7	Ø240x(H)150
831502	10	0,7	Ø280x(H)170
831601	15	0,8	Ø320x(H)190
831700	23,5	1	Ø360x(H)230



833506

With extra hook to support while draining

**PASTA COOKER BASKET**

- Suitable for stew pan Ø 360mm - prod. no. 831700
- With extra hook to support while draining

code	liter	mm
833506	1,5	160x(H)230







# PAN SERIES PROFI LINE



830604



830505



830406



830208



830000



## STEW PAN LOW - WITH LID

code	liter	wall (mm)	mm
830000	1,5	0,7	Ø160x(H)75
830208	2,8	0,7	Ø200x(H)90
830406	4,8	0,7	Ø240x(H)105
830505	7,5	0,7	Ø280x(H)120
830604	12	0,8	Ø320x(H)150

830048

830055

830154

830253



## SAUCEPAN - WITHOUT LID

- Long hollow handle of stainless steel.

code	liter	wall (mm)	mm
830048	1	0,7	Ø140x(H)70
830055	1,5	0,7	Ø160x(H)75
830154	2	0,7	Ø180x(H)80
830253	3	0,7	Ø200x(H)90





830352

### SAUTÉ PAN - WITHOUT LID

- Long hollow handle of stainless steel.

code	liter	wall (mm)	mm
830352	0,9	0,7	Ø160x(H)60
830376	1,5	0,7	Ø200x(H)60



830376



835432

### FRYING PAN - WITHOUT LID

- Long hollow handle of stainless steel.

code	wall (mm)	mm
835432	0,7	Ø240x(H)45
835531	0,7	Ø280x(H)50
835630	0,7	Ø320x(H)55



835531

835630



835401

### FRYING PAN, WITH NON-STICK COATING - WITHOUT LID

- Teflon® Platinum Plus non-stick coating.
- Long hollow handle of stainless steel.
- Riveted handle.

code	wall (mm)	mm
835401	0,7	Ø240x(H)45
835500	0,7	Ø280x(H)50
835609	0,7	Ø320x(H)55



835500

835609



Full range of the induction cookers on page 146





## PAN SERIES KITCHEN LINE

- Encapsulated sandwich type bottom.
- Combines the heat distribution of aluminium with the durability and magnetic properties of steel to allow induction cooking.
- The bottom is formed by special impact bonding, causing the whole surface of the component layers to weld seamlessly - this guarantees corrosion resistance and optimal heat conduction.
- Satin finish of all outer surfaces.
- Steel handles affixed with multi-point welding stay cool enough to touch.

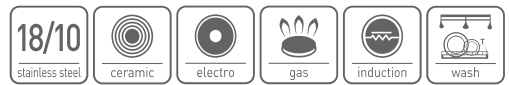

See movie

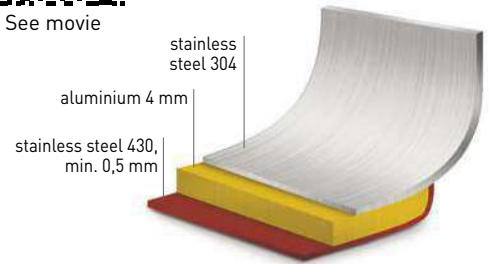

### STEW PAN HIGH - WITH LID

code	liter	wall (mm)	mm
837108	2,8	0,6	Ø160x(H)140
837207	5	0,6	Ø200x(H)160
837306	9	0,6	Ø240x(H)200
837405	13,5	0,7	Ø280x(H)220
837603	20	0,8	Ø320x(H)270



### STEW PAN MIDDLE - WITH LID

code	liter	wall (mm)	mm
836101	1,7	0,6	Ø160x(H)95
836200	3,5	0,6	Ø200x(H)115
836309	5,5	0,6	Ø240x(H)135
836408	9	0,7	Ø280x(H)155
836507	15	0,8	Ø320x(H)190



### STEW PAN LOW - WITH LID

code	liter	wall (mm)	mm
836002	1,5	0,6	Ø160x(H)75
836019	3	0,6	Ø200x(H)95
836026	5	0,6	Ø240x(H)115
836033	7,4	0,7	Ø280x(H)120
836040	12	0,8	Ø320x(H)150



Encapsulated bottom



Steam release holes



Handles don't get hot

### SAUCEPAN - WITHOUT LID

- Long hollow handle of stainless steel.

code	liter	wall (mm)	mm
838105	1,5	0,6	Ø160x(H)75
838204	3	0,6	Ø200x(H)95
838303	5	0,6	Ø240x(H)115



838105

838204

838303

### SAUTÉ PAN - WITHOUT LID

- Long hollow handle of stainless steel.

code	liter	wall (mm)	mm
839409	1,6	0,6	Ø200x(H)75



839409

### FRYING PAN - WITHOUT LID

- Long hollow handle of stainless steel.

code	wall (mm)	mm
838501	0,6	Ø240x(H)45
838600	0,6	Ø280x(H)50
838617	0,7	Ø320x(H)55



838501

838600

838617

### PAN SUPPORT ADAPTER

- For placing small pans on large pan supports

code	mm
839997	255x255x(H)25



839997







## PAN SERIES BUDGET LINE

- Sandwich type bottom (stainless steel / aluminium / 18/0 stainless steel) combines the heat distribution of aluminium with the durability and magnetic properties of stainless steel to allow induction cooking.
- Satin finish of all outer surfaces.
- Riveted stainless steel handles which don't get hot.
- Lid with steam release holes.

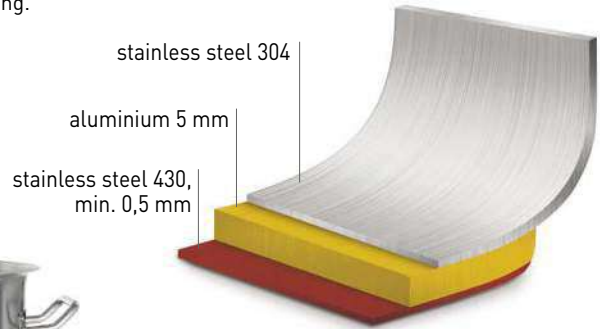

### STEW PAN WITH LID

code	liter	wall (mm)	mm	
832882	17	0,8	Ø280x(H)280	<b>NEW!</b>
832899	21	0,8	Ø300x(H)300	<b>NEW!</b>
834206	22	0,8	Ø320x(H)280	
834404	37	0,8	Ø360x(H)360	
834701	50	0,8	Ø400x(H)400	
834909	71	1	Ø450x(H)450	
835104	98	1	Ø500x(H)500	

### STEW PAN MIDDLE - WITH LID

**NEW!**

code	liter	wall (mm)	mm
832820	9	0,8	Ø250x(H)180
832837	14	0,8	Ø300x(H)200
832844	24	0,8	Ø360x(H)240
832851	32	0,8	Ø400x(H)260

Sandwich type bottom



Riveted handle



Handles don't get hot





## PAN SERIES ALUMINIUM PROFI LINE

- Wall thickness min. 2.5 mm.
- High-gloss polished rim.
- Lightweight, very solid design.
- With strong double riveted aluminium handles.
- Aluminium pans have superior heat conduction and cooking properties.



### STEW PAN - WITH LID

code	liter	mm
611104	5,5	Ø205x(H)180
611302	9,5	Ø240x(H)210
611401	10	Ø250x(H)235
611500	15,5	Ø280x(H)250
611609	19	Ø300x(H)280
611708	23	Ø325x(H)285
612002	27,5	Ø335x(H)330
612101	33,5	Ø355x(H)340
612200	38,5	Ø375x(H)360
612309	45	Ø400x(H)360
612408	64,5	Ø460x(H)415
612507	88	Ø520x(H)445



611500

### BOMBE PAN - WITH LID

- With rounded bottom

code	liter	mm
610107	13	Ø320x(H)180
610206	18	Ø360x(H)200
610305	26	Ø400x(H)220



610206

### SAUCEPAN - WITHOUT LID

code	liter	mm
613009	1	Ø160x(H)80
613108	1,5	Ø180x(H)90
613207	2,5	Ø200x(H)100



613009

Ideal for cooking pasta,  
rice and dumplings



619100



613603

### RICE STEAMER BASKET - PERFORATED

code	for	liter	mm
619100	611708	21	Ø320x(H)270
619209	612101	29	Ø360x(H)290
619308	612309	41	Ø400x(H)330

### DUMPLINGS, RICE AND PASTA STEAMER - WITH BASKET AND LID

- Perforated basket.

code	liter	mm
613603	30	Ø325x(H)370
613702	40	Ø355x(H)405
613801	55	Ø400x(H)445



## FRYING PANS DIE-CAST ALUMINIUM 'TITANIUM PROFESSIONAL'

- Made of cast aluminium, suitable for all heat sources and even suitable for use in ovens (up to 250°C).
- Cast aluminium excels at conducting heat, the pan is quickly ready for use.
- The handle is made from 18/10 stainless steel and remains cool during use.
- The Whitford® Xylan non-stick coating has a high temperature resistance (up to 250°C). Adhesion of the non-stick coating is improved by a layer of titanium between the aluminium and the coating. This double-layer procedure improves the service life of the coating and provides additional scratch-resistance.
- Very easy to clean after use.

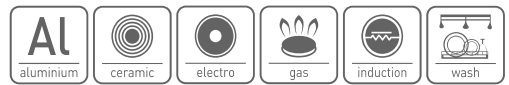

## INDUCTION FRYING PAN

code	bottom (mm)	mm
629154	Ø180	Ø240x(H)50
629253	Ø220	Ø280x(H)55
629345	Ø260	Ø320x(H)60

629154

629253

629345



Primer coating: for anti-corrosion, anti-shock & better durability of coatings

Titanium coating: for anti-scratch & anti-abrasion

Mid coating: Whitford® Xylan non-stick

Top coating: Reinforcement of non stick layer and brighten surface.

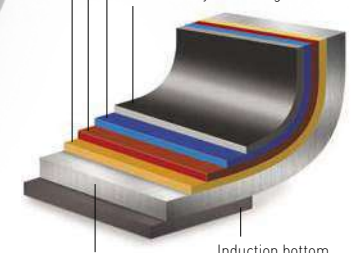

Full range of the induction cookers on page 146

With strong stainless steel handle

Induction bottom

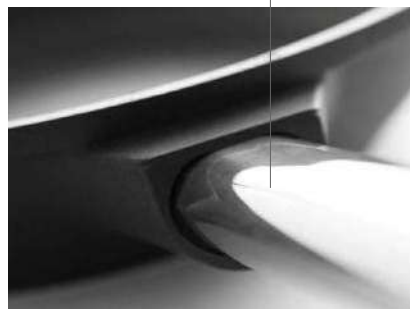

# NEW!

629130



## GRIDDLE FOR INDUCTION COOKERS

- Suitable for use on induction stoves.
- Made of die cast aluminum with Teflon® non-stick coating.

code	mm
629130	390x260x(H)35



## FRYING PANS DIE-CAST ALUMINIUM 'TITANIUM PROFESSIONAL'

- Made of cast aluminium, suitable for all heat sources except induction and even suitable for use in ovens (up to 250°C).
- Cast aluminium excels at conducting heat, the pan is quickly ready for use.
- The handle is made from 18/10 stainless steel and remains cool during use.
- The Whitford® Xylan non-stick coating has a high temperature resistance (up to 250°C). Adhesion of the non-stick coating is improved by a layer of titanium between the aluminium and the coating. This double-layer procedure improves the service life of the coating and provides additional scratch-resistance.
- Very easy to clean after use.

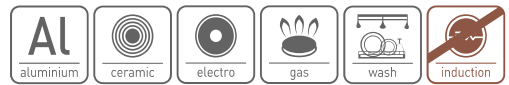

Primer coating: for anti-corrosion, anti-shock & better durability of coatings

Titanium coating: for anti-scratch & anti-abrasion

Mid coating: Whitford® Xylan non-stick  
Reinforcement of non stick and bright surface

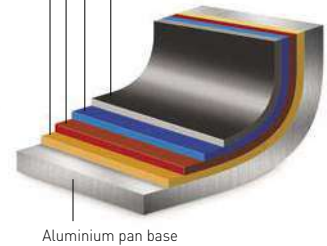

### FRYING PAN

code	bottom (mm)	mm
629109	Ø180	Ø240x(H)55
629208	Ø220	Ø280x(H)55
629307	Ø260	Ø320x(H)55
629352	Ø300	Ø360x(H)55
629390	Ø340	Ø400x(H)55



### GRILL PAN - RIDGED SURFACE

code	bottom (mm)	mm
629802	Ø220	280x280x(H)55



### SAUTÉ PAN

code	bottom (mm)	mm
629505	Ø225	Ø280x(H)85



### FISH FRYING PAN - OVAL

code	bottom (mm)	mm
629604	Ø175	400x275x(H)35



### CRÊPES PAN

code	bottom (mm)	mm
629413	Ø260	Ø320x(H)20



## FRYING PANS ALUMINIUM 'MARBLE PROFESSIONAL'

- Made of durable aluminium, suitable for all heat sources, even suitable for use in ovens.
- Aluminum offers even heat conduction, the pan is quickly ready for use.
- The handle is made of epoxy coated steel.
- The 'Marble' non-stick coating has a high temperature resistance (up to 260°C). The coating is applied in three layers and is wear-resistant.
- Very easy to clean after use.



### FRYING PAN

code	thickness (mm)	bottom (mm)	mm
627600	4	Ø140	Ø200x(H)40
627617	4	Ø180	Ø240x(H)42
627662	4	Ø200	Ø260x(H)45
627624	4	Ø220	Ø280x(H)50
627631	4	Ø260	Ø320x(H)50
627648	4	Ø280	Ø360x(H)50
627655	4	Ø300	Ø390x(H)50



627655

627624

627600

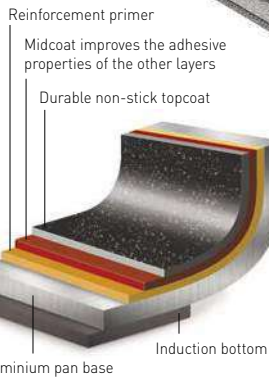

### WOK PAN

code	thickness (mm)	bottom (mm)	mm
627730	4	Ø210	Ø280x(H)75
627747	4	Ø210	Ø320x(H)100



627747



627686



627716

### CRÊPES PAN

code	thickness (mm)	bottom (mm)	mm
627679	4	Ø240	Ø280x(H)25
627686	4	Ø280	Ø320x(H)20

### FISH FRYING PAN - OVAL

code	thickness (mm)	bottom (mm)	mm
627716	4	Ø185	280x400x(H)55



## FRYING PANS ALUMINIUM 'PLATINUM PROFESSIONAL'

- Made of durable aluminium, suitable for all heat sources.
- Aluminium excels at conducting heat, the pan is quickly ready for use.
- Stainless steel handle with insulating silicon handle for a good grip.
- The 'Teflon™ Platinum Plus' non-stick coating has a high temperature resistance (up to 260°C). The coating is applied in three layers which increases the wear resistance and makes the pan ideal for intensive use.
- Very easy to clean after use.



Full range of the induction cookers on page 146

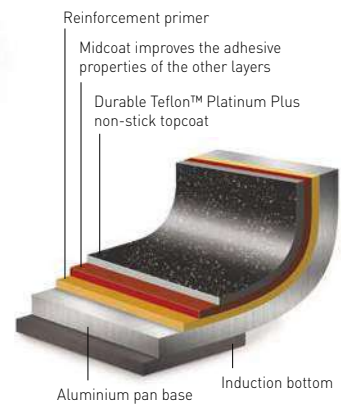

### FRYING PANS

code	thickness (mm)	bottom (mm)	mm
621103	4	Ø140	Ø200x(H)44
621110	4	Ø180	Ø240x(H)50
621127	4	Ø200	Ø260x(H)52
621134	4	Ø220	Ø280x(H)52
621158	4	Ø260	Ø320x(H)60

Induction bottom



Insulated handle



Very hard non-stick coating





## FRYING PANS CLASSIC STEEL

- Traditional frying pans made of rolled steel.
- Favourite pans of cooking masters.
- Simplicity, quality, firmness and versatility, features appreciated by many generations.



### FRYING PAN

code	thickness (mm)	bottom (mm)	mm
628591	3	Ø150	Ø200x(H)45
628638	3	Ø180	Ø240x(H)45
628607	3	Ø190	Ø250x(H)50
628614	3	Ø220	Ø280x(H)50
628706	3	Ø240	Ø300x(H)50
628621	3	Ø260	Ø320x(H)50
628713	3	Ø280	Ø370x(H)55



See movie



628805



628850

### CRÊPES PAN

code	thickness (mm)	bottom (mm)	mm
628805	2,5	Ø190	Ø230x(H)25

### BLINIS FRYING PAN

code	thickness (mm)	bottom (mm)	mm
628850	2,5	Ø100	Ø140x(H)35

### BEFORE FIRST USE



**Step 1**  
Put cooking oil in the pan and heat it. Add potato peelings and a lot of salt, then let it fry a bit.



**Step 2**  
Take a kitchen towel and carefully rub the mixture around the inside of the pan.



**Step 3**  
After rubbing the pan thoroughly, empty the pan. Now there will be residue of the potato peelings left in the pan.



**Step 4**  
To remove the residue put a lot of salt in the pan and rub the salt around the pan with a kitchen towel to remove the residue. Don't do this on the stove.



**Step 5**  
Remove the dirty salt, wipe the pan clean and pour a thin layer of oil in the pan.



**Step 6**  
Spread the oil in the pan with a clean kitchen towel. The pan is now ready for first use or storage.





### WOK 3-PLY - WITHOUT LID

- Fast heating and excellent heat distribution.
- Very durable through high wear resistance.
- Long hollow handle made of stainless steel.
- Flat bottom of Ø 145 mm.

code	mm
839003	Ø360x(H)90



839003

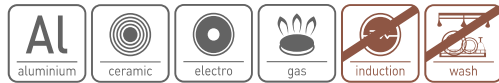

### GOURMET PAN

- Non-stick coating.
- Perfect for serving scrambled eggs, shrimps and other hot snacks and small dishes.
- Handle made of phenolic resin.

code	packed per	mm
110126	2	Ø140x(H)30

**NEW!  
MODEL!**



110126

Perforated rack for easy draining and lifting food out of the poacher



508527

### ROASTING PAN

- With handles.
- Only suitable for ovens, not for direct contact heating.



code	mm
508503	315x245x(H)50
508510	385x275x(H)60
508527	430x310x(H)60

**NEW!**



### FISH POACHER 60CM

- With an insert elevation plate to poach the fish.
- The kettle is easy to clean and maintain.

code	mm
836057	705x185x(H)160

836057



## MUSSEL & GRAVY PANS



625002



625057



625101



### MUSSEL PAN - WITH LID

- Black enamel.
- Flanged stainless steel rim.

code	max. contents in kg. (ca.)	liter	mm
625002	1,2	2,3	Ø190x(H)120/190
625057	1,6	3,0	Ø210x(H)130/200
625101	2,4	5,0	Ø225x(H)140/210



625606



625804



625705



### GRAVY PAN - WITH LID

- Black enamel.
- Flanged stainless steel rim.

code	liter	mm
625606	0,8	Ø125x(H)90/145

### SOUP & GRAVY PAN - WITH LID

- Enamelled.
- Flanged stainless steel rim.
- Low lid.

code		liter	mm
625804	blue	0,3	Ø120x(H)95
625705	black	0,6	Ø135x(H)103

## FRYING PANS PAELLA



622704



622728



622742

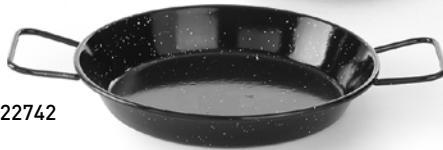

622841

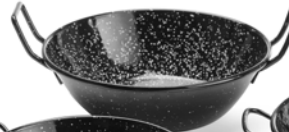

622858



622834



622827

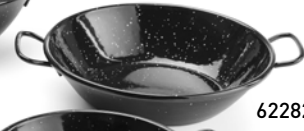

622810



### ENAMELLED PAELLA PANS

- With 2 handles.
- Enamelled sheet steel.

code	mm
622704	Ø100x(H)20
622711	Ø120x(H)25
622728	Ø150x(H)27
622735	Ø200x(H)36
622742	Ø240x(H)40

### ENAMELLED PAELLA BOWLS

- Deep model.
- Enamelled sheet steel.

code	mm
622810	Ø145x(H)40
622827	Ø170x(H)40
622834	Ø185x(H)43
622841	Ø205x(H)57
622858	Ø245x(H)70



### PAELLA PAN

- Top-quality frying pans made of sheet steel.
- With 2 handles.

code	mm	
622100	Ø340x(H)40	
622308	Ø460x(H)40	
622407	Ø600x(H)40	Fiesta gas grill 146002
622605	Ø800x(H)50	Fiesta gas grill 146804





# Gastronorm containers

**GASTRONORM  
CONTAINER  
PROFI LINE**
**GASTRONORM  
CONTAINER  
KITCHEN LINE**
**GASTRONORM  
CONTAINER  
BUDGET LINE**
**GASTRONORM  
CONTAINER  
TRITAN BPA FREE**
**GRILAMID GN  
CONTAINER FOR HIGH  
TEMPERATURES**

	<b>GASTRONORM CONTAINER PROFI LINE</b>	<b>GASTRONORM CONTAINER KITCHEN LINE</b>	<b>GASTRONORM CONTAINER BUDGET LINE</b>	<b>GASTRONORM CONTAINER TRITAN BPA FREE</b>	<b>GRILAMID GN CONTAINER FOR HIGH TEMPERATURES</b>
<b>SUITABLE FOR:</b>					
Convection ovens	✓	✓	✓		
Bain-marie system	✓	✓	✓		✓
Chafing dishes	✓	✓	✓		✓
Refrigerators	✓	✓	✓	✓	✓
Food storage	✓	✓	✓	✓	✓
Dishwasher cleaning	✓	✓	✓	✓	✓
<b>PROPERTIES:</b>					
For use at temperatures	-40°C / 300°C	-40°C / 300°C	-40°C / 300°C	-40° / 90°C	-40°C / 150°C
Stackable	✓	✓	✓	✓	✓
<b>CONSTRUCTION:</b>					
Made of	stainless steel 18/10	stainless steel	stainless steel	tritan	grilamid
Thickness (mm)	0,6-0,8	0,6-0,7	0,6-0,7		2-2,9
Available heights (mm)	20 up to 200	20 up to 200	20 up to 200	65 up to 200	65 up to 150
<b>ACCESSORIES:</b>					
Perforated containers	✓	✓			
Lids	✓	✓	✓	✓	✓
Lids with silicone rim		✓	✓		
Lids with spoon recess	✓	✓			
Dripping tray				✓	
Adaptor bar	✓	✓	✓		
<b>ADDITIONAL INFO:</b>					
Easy to clean	✓	✓	✓	✓	✓
Gastronorm size engraved		✓		✓	✓
With capacity scale				✓	✓
Doesn't absorb odours or flavours	✓	✓	✓	✓	✓
	<ul style="list-style-type: none"> <li>Compliant with the most strict food contact regulations (for hospitals)</li> <li>•</li> <li>Excellent corrosion resistance (salt &amp; sour resistant)</li> <li>•</li> <li>Reduced radius to ensure maximum content</li> <li>•</li> <li>Very strong and durable</li> </ul>	<ul style="list-style-type: none"> <li>Reinforced corners to add strenght</li> <li>•</li> <li>If treated correctly corrosion resistant</li> </ul>	<ul style="list-style-type: none"> <li>If treated correctly corrosion resistant</li> </ul>	<ul style="list-style-type: none"> <li>Bisphenol A Free</li> <li>•</li> <li>High impact resistance, very durable</li> <li>•</li> <li>With capacity scale</li> <li>•</li> <li>Cristal clear material</li> </ul>	<ul style="list-style-type: none"> <li>Can be used in bain-marie system and chafing dishes</li> <li>•</li> <li>Stable in cooking water, sterilizable at steam 134°C &gt; 200 cycles</li> <li>•</li> <li>High impact resistance, very durable</li> </ul>
<b>MORE ON PAGE:</b>	20-21	22-23	24-25	26	27





**GASTRONORM  
CONTAINER  
POLYCARBONATE  
TRANSPARENT**



**GASTRONORM  
CONTAINER  
POLYCARBONATE**



**GASTRONORM  
CONTAINER  
POLYPROPYLENE**



**HACCP  
STORAGE  
CONTAINER**



**PORCELAIN  
CONTAINER**

				✓
✓	✓	✓	✓	✓
✓	✓	✓	✓	✓
✓	✓	✓	✓	✓
-40°C / 110°C	-40°C / 110°C	-40°C / 80°C	-40°C / 80°C	under 600°C
✓	✓	✓	✓	✓
polycarbonate	polycarbonate	polypropylene	polypropylene	porcelain
2-3	2-3			
65 up to 200	65 up to 150	100 up to 200	65 up to 200	20 up to 65
✓	✓	✓	✓	
✓				
✓	✓	✓	✓	✓
✓	✓	✓	✓	✓
✓	✓	✓	✓	✓
High impact resistance, very durable	Perfect for presentation	Transparent material	With integrated HACCP label for monitoring of food storage process	Special porcelain type, toughest type available
• Crystal clear material	• High impact resistance, very durable		• Transparent material	• Thermal shock resistant, can withstand extreme temperature changes
	• Crystal clear material		• Coloured lid clips according to HACCP sold separately	• High-impact and wear resistance and still relatively light-weight
				• Extremely pure and brilliant white
29	30-31	28	32-33	390

**GASTRONORM CONTAINERS PROFI LINE**

- Made of high grade stainless steel 18/10.
- Very solid design.
- Smooth edges, easy to clean.
- Can be used in convection ovens, refrigerators, bain-marie systems and chafing dishes.

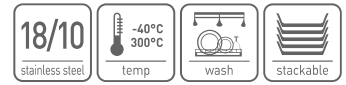

height (mm)



**GASTRONORM CONTAINER 1/1**  
- 530x325 mm

code	liter	thickness (mm)	height (mm)
801208	28,0	0,8	200
801215	21,0	0,8	150
801222	14,0	0,8	100
801239	9,0	0,8	65
801246	5,0	0,8	40
801253	2,5	0,8	20

**GASTRONORM CONTAINER 2/3**  
- 354x325 mm

code	liter	thickness (mm)	height (mm)
801307	18,0	0,8	200
801314	13,0	0,8	150
801321	9,0	0,7	100
801338	5,5	0,7	65
801345	3,0	0,7	40
801352	1,5	0,7	20

**GASTRONORM CONTAINER 2/4**  
- 530x162 mm

code	liter	thickness (mm)	height (mm)
801840	8,6	0,7	150
801666	5,8	0,7	100
801857	4,0	0,7	65
801864	2,5	0,7	40
801871	1,2	0,7	20



801420

**GASTRONORM CONTAINER 1/2**  
- 325x265 mm

code	liter	thickness (mm)	height (mm)
801406	12,5	0,8	200
801413	9,5	0,7	150
801420	6,5	0,7	100
801437	4,0	0,7	65
801444	2,0	0,7	40
801451	1,0	0,7	20



801529

**GASTRONORM CONTAINER 1/3**  
- 325x176 mm

code	liter	thickness (mm)	height (mm)
801505	7,8	0,8	200
801512	5,7	0,7	150
801529	4,0	0,7	100
801536	2,5	0,7	65
801543	1,5	0,7	40
801550	0,8	0,7	20



801628

**GASTRONORM CONTAINER 1/4**  
- 265x162 mm

code	liter	thickness (mm)	height (mm)
801604	5,5	0,8	200
801611	4,0	0,7	150
801628	2,8	0,7	100
801635	1,8	0,7	65
801642	1,7	0,7	40
801659	0,9	0,7	20



801727

**GASTRONORM CONTAINER 1/6**  
- 176x162 mm

code	liter	thickness (mm)	height (mm)
801703	3,4	1,0	200
801710	2,4	0,8	150
801727	1,6	0,7	100
801734	1,0	0,7	65



801826

**GASTRONORM CONTAINER 1/9**  
- 176x108 mm

code	liter	thickness (mm)	height (mm)
801826	1,0	0,7	100
801833	0,6	0,7	65



802236

**GASTRONORM CONTAINER 1/1 PERFORATED** - 530x325 mm

code	liter	thickness (mm)	height (mm)
802205	28	0,8	200
802212	21	0,8	150
802229	14,0	0,8	100
802236	9,0	0,8	65
802243	5,0	0,8	40
802168	2,5	0,8	20



802328

**GASTRONORM CONTAINER 2/3 PERFORATED**  
- 354x325 mm

code	liter	thickness (mm)	height (mm)
802328	9,0	0,7	100
802335	5,5	0,7	65
802342	3,0	0,7	40



802427

**GASTRONORM CONTAINER 1/2 PERFORATED**  
- 325x265 mm

code	liter	thickness (mm)	height (mm)
802427	6,5	0,7	100
802434	4,0	0,7	65
802441	2,0	0,7	40



802526

**GASTRONORM CONTAINER 1/3 PERFORATED** - 325x176 mm

code	liter	thickness (mm)	height (mm)
802502	7,8	0,7	200
802519	5,7	0,7	150
802526	4,0	0,7	100
802533	2,5	0,7	65
802540	1,2	0,7	40



804100

**GASTRONORM LID**

code	thickness (mm)	mm
804100	0,8	GN 1/1 - 530x325
804117	0,7	GN 2/3 - 354x325
804179	0,8	GN 2/4 - 530x162
804124	0,7	GN 1/2 - 265x325
804131	0,7	GN 1/3 - 325x176
804148	0,7	GN 1/4 - 265x162
804155	0,7	GN 1/6 - 176x162
804162	0,7	GN 1/9 - 176x108



With spoon recess

805114

**GASTRONORM LID WITH SPOON RECESS**

code	thickness (mm)	mm
805107	0,7	GN 1/1 - 530x325
805114	0,7	GN 2/3 - 354x325
805121	0,7	GN 1/2 - 265x325
805138	0,7	GN 1/3 - 325x176
805145	0,7	GN 1/4 - 265x162
805152	0,7	GN 1/6 - 176x162



802601

**GASTRONORM LID WITH SILICONE RIM**

- With silicone rim for airtight sealing.  
- Only suitable for 'Profi-Line' and polycarbonate gastronorm containers.

code	mm
802601	GN 1/1 - 530x325
802618	GN 2/3 - 354x325
802625	GN 1/2 - 265x325
802632	GN 1/3 - 325x176
802649	GN 1/4 - 265x162
802656	GN 1/6 - 176x162

## GASTRONORM CONTAINERS KITCHEN LINE

- Extra strong due to reinforced corners. Gastronorm size is engraved.
- Smooth edges, easy to clean.
- Can be used in convection ovens, refrigerators, bain-marie systems and chafing dishes.

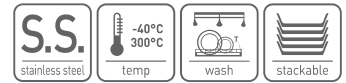

height (mm)



20

40

65

100

150

200



806142



806241



806340

**GASTRONORM CONTAINER 1/1**  
 - 530x325 mm

code	liter	thickness (mm)	height (mm)
806159	26,4	0,7	200
806142	19,8	0,7	150
806135	13,2	0,6	100
806128	8,6	0,6	65
806111	5,3	0,6	40
806104	2,6	0,6	20

**GASTRONORM CONTAINER 2/3**  
 - 354x325 mm

code	liter	thickness (mm)	height (mm)
806258	15,5	0,7	200
806241	11,6	0,7	150
806234	7,7	0,6	100
806227	5,0	0,6	65
806210	3,0	0,6	40
806203	1,5	0,6	20

**GASTRONORM CONTAINER 1/2**  
 - 325x265 mm

code	liter	thickness (mm)	height (mm)
806357	11,0	0,7	200
806340	8,4	0,7	150
806333	5,6	0,6	100
806326	3,6	0,6	65
806319	2,2	0,6	40
806302	1,1	0,6	20





806449

**GASTRONORM CONTAINER 1/3**  
- 325x176 mm

code	liter	thickness (mm)	height (mm)
806456	6,8	0,7	200
806449	5,1	0,7	150
806432	3,4	0,6	100
806425	2,2	0,6	65
806418	1,3	0,6	40
806401	0,6	0,6	20



806548

**GASTRONORM CONTAINER 1/4**  
- 265x162 mm

code	liter	thickness (mm)	height (mm)
806555	5,5	0,7	200
806548	4,1	0,7	150
806531	2,7	0,6	100
806524	1,8	0,6	65



806647

**GASTRONORM CONTAINER 1/6**  
- 176x162 mm

code	liter	thickness (mm)	height (mm)
806654	3,2	0,7	200
806647	2,4	0,7	150
806630	1,6	0,6	100
806623	1,0	0,6	65



806739

**GASTRONORM CONTAINER 1/9**  
- 176x108 mm

code	liter	thickness (mm)	height (mm)
806739	1,0	0,7	100
806722	0,6	0,6	65



808153

808108

**ADAPTOR BAR FOR GASTRONORM CONTAINERS**

- For fitting small GN-containers in bain-maries, chafing dishes etc.

code	mm
808153	GN 1/1 - 532x20
808108	GN 1/2 - 325x20

**NEW!**



806197

**GASTRONORM PERFORATED INSERTS**

code	mm
806197	GN 1/1
806296	GN 2/3
806395	GN 1/2
806494	GN 1/3
806593	GN 1/4
806692	GN 1/6



807132

**GASTRONORM CONTAINER 1/1 PERFORATED**  
- 530x325 mm

code	liter	thickness (mm)	height (mm)
807132	13,2	0,6	100
807125	8,6	0,6	65
807118	5,3	0,6	40



807224

**GASTRONORM CONTAINER 2/3 PERFORATED**  
- 354x325 mm

code	liter	thickness (mm)	height (mm)
807224	5,0	0,6	65

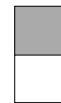

807330

**GASTRONORM CONTAINER 1/2 PERFORATED**  
- 325x265 mm

code	liter	thickness (mm)	height (mm)
807330	5,6	0,6	100
807323	3,6	0,6	65



804032

**GASTRONORM LID WITH SILICONE RIM**

- With silicone rim for airtight sealing.  
- Only suitable for 'Kitchen-Line' & 'Budget-Line' gastronorm containers.

code	thickness (mm)	mm
804001	1	GN 1/1 - 530x325
804018	0,8	GN 2/3 - 354x325
804025	0,7	GN 1/2 - 265x325
804032	0,7	GN 1/3 - 325x176
804049	0,7	GN 1/4 - 265x162
804056	0,7	GN 1/6 - 176x162



806845

**GASTRONORM LID**

code	thickness (mm)	mm
806814	0,7	GN 1/1 - 530x325
806821	0,7	GN 2/3 - 354x325
806838	0,7	GN 1/2 - 265x325
806845	0,7	GN 1/3 - 325x176
806852	0,7	GN 1/4 - 265x162
806869	0,7	GN 1/6 - 176x162
806876	0,7	GN 1/9 - 176x108



806968

**GASTRONORM LID WITH SPOON RECESS**

code	thickness (mm)	mm
806913	0,7	GN 1/1 - 530x325
806920	0,7	GN 2/3 - 354x325
806937	0,7	GN 1/2 - 265x325
806944	0,7	GN 1/3 - 325x176
806951	0,7	GN 1/4 - 265x162
806968	0,7	GN 1/6 - 176x162
806975	0,7	GN 1/9 - 176x108

## GASTRONORM CONTAINERS BUDGET LINE

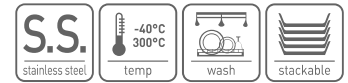

- Very solid design.
- Smooth edges, easy to clean.
- Intended for use in convection ovens, refrigerators, bain-marie systems and chafing dishes.

height  
(mm)20  
40  
65height  
(mm)100  
150  
200

800133



800232



800331

**GASTRONORM CONTAINER 1/1**  
- 530x325 mm

**GASTRONORM CONTAINER 2/3**  
- 354x325 mm

**GASTRONORM CONTAINER 1/2**  
- 325x265 mm

code	liter	height (mm)
800157	28	200
800140	21	150
800133	14	100
800126	9	65
800119	5	40
800102	2,5	20

code	liter	height (mm)
800249	13	150
800232	9	100
800225	5,5	65
800218	3	40

code	liter	height (mm)
800355	12,5	200
800348	9,5	150
800331	6,5	100
800324	4	65
800317	2	40
800300	1	20



800430

**GASTRONORM CONTAINER 1/3**

- 325x176 mm

code	liter	height (mm)
800454	7,8	200
800447	5,7	150
800430	4	100
800423	2,5	65
800416	1,5	40
800409	0,6	20



800539

**GASTRONORM CONTAINER 1/4**

- 265x162 mm

code	liter	height (mm)
800553	5,5	200
800546	4	150
800539	2,8	100
800522	1,8	65



800638

**GASTRONORM CONTAINER 1/6**

- 176x162 mm

code	liter	height (mm)
800652	3,4	200
800645	2,4	150
800638	1,6	100
800621	1	65



800737

**GASTRONORM CONTAINER 1/9**

- 176x108 mm

code	liter	height (mm)
800737	1	100
800720	0,6	65



800812

**GASTRONORM LID**

code	mm
800812	GN 1/1 - 530x325
800829	GN 2/3 - 354x325
800836	GN 1/2 - 265x325
800843	GN 1/3 - 325x176
800850	GN 1/4 - 265x162
800867	GN 1/6 - 176x162
800874	GN 1/9 - 176x108



804032

**GASTRONORM LID WITH SILICONE RIM**

- With silicone rim for airtight sealing.

- Only suitable for 'Kitchen-Line' & 'Budget-Line' gastronorm containers.

code	thickness (mm)	mm
804001	1	GN 1/1 - 530x325
804018	0,8	GN 2/3 - 354x325
804025	0,7	GN 1/2 - 265x325
804032	0,7	GN 1/3 - 325x176
804049	0,7	GN 1/4 - 265x162
804056	0,7	GN 1/6 - 176x162

**GASTRONORM CONTAINERS BUDGET LINE WITH HANDLES**



817148

**GASTRONORM CONTAINER 1/1**

- 530x325 mm

code	liter	height (mm)
817148	21	150
817155	28	200



817247

**GASTRONORM CONTAINER 2/3**

- 354x325 mm

code	liter	height (mm)
817247	13	150
817254	17	200



817346

**GASTRONORM CONTAINER 1/2**

- 325x265 mm

code	liter	height (mm)
817346	9,5	150
817353	12,5	200



817445

**GASTRONORM CONTAINER 1/3**

- 325x176 mm

code	liter	height (mm)
817445	5,7	150
817452	7,8	200



817810

**GASTRONORM LID**

- With cutout for the handles.

code	mm
817810	GN 1/1 - 530x325
817827	GN 2/3 - 354x325
817834	GN 1/2 - 325x265
817841	GN 1/3 - 325x176

## GASTRONORM CONTAINERS TRITAN BPA FREE

- Doesn't absorb odours or flavours.
- Contains no Bisphenol A.
- Very clear transparency.

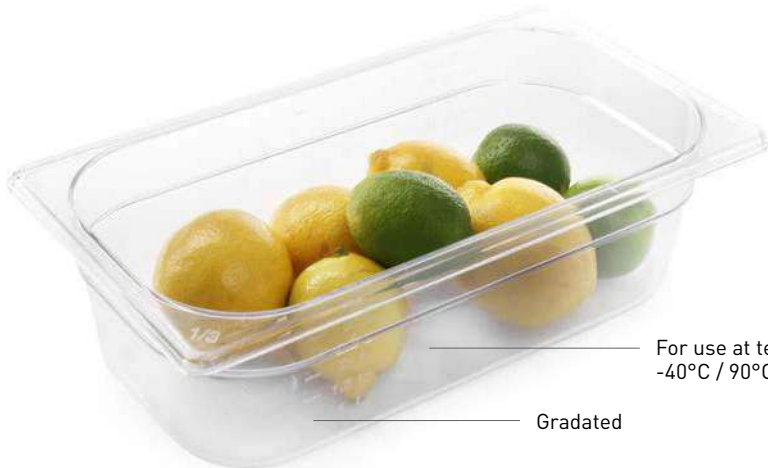
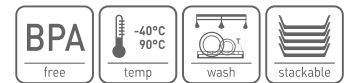

For use at temperatures  
-40°C / 90°C

Gradated



Gastronorm container made of Tritan – high quality plastic. High temperature resistant from -40°C to 90°C. Perfect for storing food in freezers, refrigerators and countertop servers.



869215

### GASTRONORM CONTAINER 1/1

- 530x325 mm

code	liter	height (mm)
869208	28,0	200
869215	21,0	150
869222	14,0	100
869239	9	65



869314

### GASTRONORM CONTAINER 1/2

- 325x265 mm

code	liter	height (mm)
869307	12,5	200
869314	9,5	150
869321	6,5	100
869338	4,0	65



869413

### GASTRONORM CONTAINER 1/3

- 325x176 mm

code	liter	height (mm)
869406	7,8	200
869413	5,7	150
869420	4,0	100
869437	2,5	65



869505

### GASTRONORM CONTAINER 1/4

- 265x162 mm

code	liter	height (mm)
869505	5,5	200
869512	4,0	150
869529	2,8	100
869536	1,8	65



869611

### GASTRONORM CONTAINER 1/6

- 176x162 mm

code	liter	height (mm)
869604	3,4	200
869611	2,4	150
869628	1,6	100
869635	1,0	65



869727

### GASTRONORM CONTAINER 1/9

- 176x108 mm

code	liter	height (mm)
869727	1,0	100
869734	0,6	65



869819

### GASTRONORM LID

code	mm
869819	GN 1/1 - 530x325
869826	GN 1/2 - 265x325
869833	GN 1/3 - 325x176
869840	GN 1/4 - 265x162
869857	GN 1/6 - 176x162
869864	GN 1/9 - 176x108



869918

### DRIPPING TRAY

code	mm
869918	GN 1/1 - 530x325
869925	GN 1/2 - 265x325

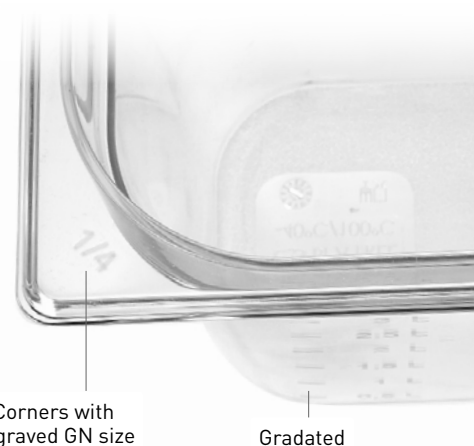

Corners with  
engraved GN size

Gradated



## GRILAMID GN CONTAINER FOR HIGH TEMPERATURES

# NEW!



- Gastronorm container made of Grilamid - high quality polyamide which is BPA free.
- High temperature resistant from -40°C to 150°C.
- Can be used in each processing phase: freezers, blast chillers, microwave ovens, bain-marie system and chafing dishes.
- High impact resistance and doesn't absorb odours or flavours.
- Very transparent with a slight yellow tint.

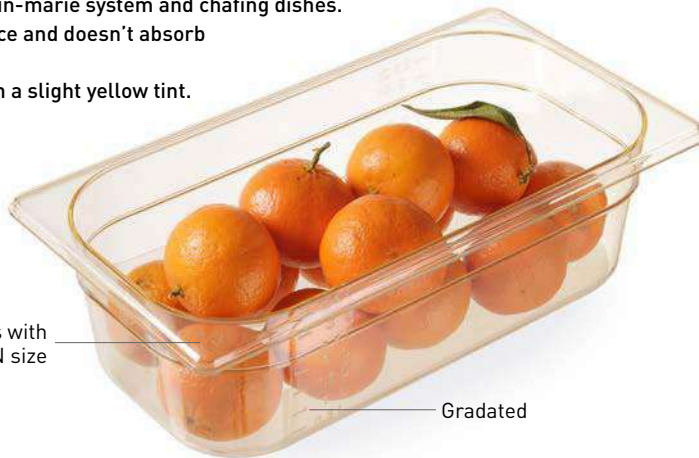

Gastronorm container made of Grilamid - high quality polyamide. High temperature resistant from -40°C to 150°C. Can be used in each processing phase: freezers, blast chillers, microwave ovens, bain-marie system and chafing dishes BPA-free



869260

### GASTRONORM CONTAINER 1/1

- 530x325 mm

code	liter	height (mm)
869260	20	150
869277	13,3	100
869284	9	65



869369

### GASTRONORM CONTAINER 1/2

- 325x265 mm

code	liter	height (mm)
869369	9,0	150
869376	6,1	100
869383	4,0	65



869475

### GASTRONORM CONTAINER 1/3

- 325x176 mm

code	liter	height (mm)
869468	5,5	150
869475	3,8	100
869482	2,5	65



869567

### GASTRONORM CONTAINER 1/4

- 265x162 mm

code	liter	height (mm)
869567	3,8	150
869574	2,6	100
869581	1,7	65



869673

### GASTRONORM CONTAINER 1/6

- 176x162 mm

code	liter	height (mm)
869666	2,3	150
869673	1,6	100
869680	1,0	65



869772

### GASTRONORM CONTAINER 1/9

- 176x108 mm

code	liter	height (mm)
869772	0,9	100
869789	0,6	65

High temperature resistant from -40°C to 150°C  
- can be used in each processing phase: freezers, blast chillers, microwave ovens, bain-marie system and chafing dishes



869949

### GASTRONORM LID

code	mm
869949	GN 1/1 - 530x325
869956	GN 1/2 - 265x325
869963	GN 1/3 - 325x176
869970	GN 1/4 - 265x162
869987	GN 1/6 - 176x162
869994	GN 1/9 - 176x108



## GASTRONORM CONTAINERS POLYPROPYLENE

- Doesn't absorb odours or flavours.

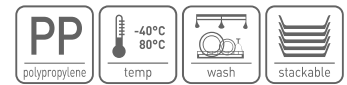

For use at temperatures  
-40°C / 80°C

Gradated



880012

**GASTRONORM CONTAINER 1/1**  
- 530x325 mm

code	liter	height (mm)
880005	28,0	200
880012	21,0	150
880029	14	100



880111

**GASTRONORM CONTAINER 1/2**  
- 325x265 mm

code	liter	height (mm)
880104	12,5	200
880111	9,5	150
880128	6,5	100



880210

**GASTRONORM CONTAINER 1/3**  
- 325x176 mm

code	liter	height (mm)
880203	7,8	200
880210	5,7	150
880227	4,0	100



880319

**GASTRONORM CONTAINER 1/4**  
- 265x162 mm

code	liter	height (mm)
880302	5,5	200
880319	4,0	150
880326	2,8	100



880418

**GASTRONORM CONTAINER 1/6**  
- 176x162 mm

code	liter	height (mm)
880401	3,4	200
880418	2,4	150
880425	1,6	100



880524

**GASTRONORM CONTAINER 1/9**  
- 176x108 mm

code	liter	height (mm)
880524	1,0	100



880609

### GASTRONORM LID

- Suitable for all Hendi polypropylene Gastronorm containers, including HACCP storage containers

code	mm
880609	GN 1/1 - 530x325
880616	GN 1/2 - 325x265
880623	GN 1/3 - 325x176
880630	GN 1/4 - 265x162
880647	GN 1/6 - 176x162
880654	GN 1/9 - 176x108



881811

### GASTRONORM LIDS AIRTIGHT SEAL

- Lid with airtight silicone seal, seal is strong enough to prevent leaking when container is tilted.  
- With lip to break the airtight seal for easy opening.

code	mm
881804	GN1/1
881811	GN1/2
881828	GN1/3

**NEW!**

**SIL**  
silicone



## GASTRONORM CONTAINERS POLYCARBONATE TRANSPARENT

- High quality professional Gastronorm containers made of transparent polycarbonate.
- Doesn't absorb odours or flavours.

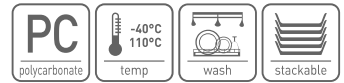

861202

**GASTRONORM CONTAINER 1/1**  
- 530x325 mm

code	liter	height (mm)
861202	28,0	200
861219	21,0	150
861226	14,0	100
861233	9,0	65



861424

**GASTRONORM CONTAINER 1/2**  
- 325x265 mm

code	liter	height (mm)
861400	12,5	200
861417	9,5	150
861424	6,5	100
861431	4,0	65



861523

**GASTRONORM CONTAINER 1/3**  
- 325x176 mm

code	liter	height (mm)
861509	7,8	200
861516	5,7	150
861523	4,0	100
861530	2,5	65



861622

**GASTRONORM CONTAINER 1/4**  
- 265x162 mm

code	liter	height (mm)
861608	5,5	200
861615	4,0	150
861622	2,8	100
861639	1,8	65



861721

**GASTRONORM CONTAINER 1/6**  
- 176x162 mm

code	liter	height (mm)
861707	3,4	200
861714	2,4	150
861721	1,6	100
861738	1,0	65



861820

**GASTRONORM CONTAINER 1/9**  
- 176x108 mm

code	liter	height (mm)
861820	1,0	100
861837	0,6	65



864104

### GASTRONORM LID

- Without spoon recess.
- Also suitable for stainless steel Profi Line Gastronorm containers.

code	mm
864104	GN 1/1 - 530x325
864128	GN 1/2 - 265x325
864135	GN 1/3 - 325x176
864142	GN 1/4 - 265x162
864159	GN 1/6 - 176x162
864166	GN 1/9 - 176x108



868522

### DRIPPING TRAY

code	mm
868522	GN 1/1 - 530x325
868546	GN 1/2 - 325x265
868553	GN 1/3 - 325x176
868577	GN 1/6 - 172x162

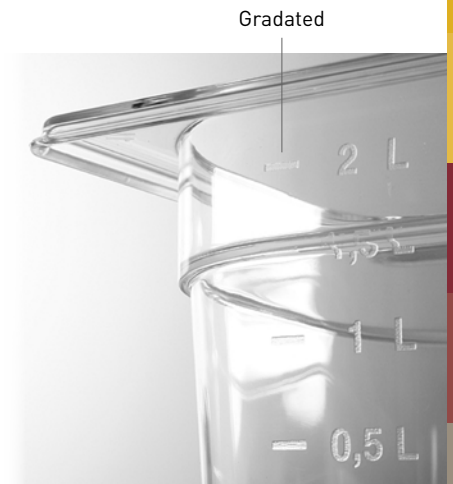

**GASTRONORM CONTAINERS POLYCARBONATE BLACK**

- High quality professional Gastronorm containers made of black polycarbonate.
- Doesn't absorb odours or flavours.



For use at temperatures  
-40°C / 110°C

Gradated

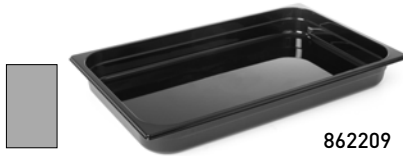

862209

**GASTRONORM CONTAINER 1/1**

- 530x325 mm

code	liter	height (mm)
862216	21,0	150
862223	14,0	100
862209	9,0	65



862421

**GASTRONORM CONTAINER 1/2**

- 325x265 mm

code	liter	height (mm)
862407	12,5	200
862414	9,5	150
862421	6,5	100
862438	4,0	65



862513

**GASTRONORM CONTAINER 1/3**

- 325x176 mm

code	liter	height (mm)
862506	7,8	200
862513	5,7	150
862520	4,0	100
862537	2,5	65



862629

**GASTRONORM CONTAINER 1/4**

- 265x162 mm

code	liter	height (mm)
862612	4,0	150
862629	2,8	100
862636	1,8	65



862711

**GASTRONORM CONTAINER 1/6**

- 176x162 mm

code	liter	height (mm)
862704	3,4	200
862711	2,4	150
862728	1,6	100
862735	1,0	65



862827

**GASTRONORM CONTAINER 1/9**

- 176x162 mm

code	liter	height (mm)
862827	1,0	100



862902

**GASTRONORM LID**

code	mm
862902	GN 1/1 - 530x325
862926	GN 1/2 - 325x265
862933	GN 1/3 - 325x176
862940	GN 1/4 - 265x162
862957	GN 1/6 - 176x162





## GASTRONORM CONTAINERS POLYCARBONATE WHITE

**NEW!**

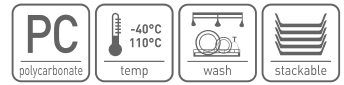

- High quality professional Gastronorm containers made of white polycarbonate.
- Doesn't absorb odours or flavours.



For use at temperatures  
-40°C / 110°C

Gradated



862285

### GASTRONORM CONTAINER 1/1

- 530x325 mm

code	liter	height (mm)	mm
862285	9,0	65	530x325



862476

### GASTRONORM CONTAINER 1/2

- 325x265 mm

code	liter	height (mm)	mm
862476	6,5	100	325x265
862483	4,0	65	325x265



862575

### GASTRONORM CONTAINER 1/3

- 325x176 mm

code	liter	height (mm)	mm
862568	5,7	150	325x176
862575	4,0	100	325x176
862582	2,5	65	325x176



862674

### GASTRONORM CONTAINER 1/4

- 265x162 mm

code	liter	height (mm)	mm
862674	2,8	100	265x162
862681	1,8	65	265x162



862773

### GASTRONORM CONTAINER 1/6

- 176x162 mm

code	liter	height (mm)	mm
862766	2,4	150	176x162
862773	1,6	100	176x162
862780	1,0	65	176x162



862964

### GASTRONORM LID

code	mm
862919	GN 1/1 - 530x325
862964	GN 1/2 - 265x325
862971	GN 1/3 - 325x176
862988	GN 1/4 - 265x162
862995	GN 1/6 - 176x162

## HACCP STORAGE CONTAINERS

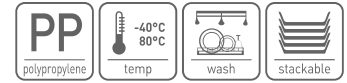

- Airtight sealing.
- Odour and flavour free.
- Lids and lid clips (green, yellow, blue, red or purple as per HACCP guidelines) available separately.
- Wear-resistant label for monitoring of food storage process.
- Special erasable markers to write on the labels are not included.



880050

## STORAGE CONTAINER GASTRONORM 1/1

- 530x325 mm

code	liter	height (mm)
880050	28	200
880067	21	150
880074	14	100
880036	9	65



880159

## STORAGE CONTAINER GASTRONORM 1/2

- 325x265 mm

code	liter	height (mm)
880159	12,5	200
880166	9,5	150
880173	6,5	100



880258

**STORAGE CONTAINER GASTRONORM 1/3**  
- 325x176 mm

code	liter	height (mm)
880258	7,8	200
880265	5,7	150
880272	4,0	100
880289	2,5	65



880371

**STORAGE CONTAINER GASTRONORM 1/4**  
- 265x162 mm

code	liter	height (mm)
880357	5,5	200
880364	4,0	150
880371	2,8	100
880388	1,8	65



880456

**STORAGE CONTAINER GASTRONORM 1/6**  
- 176x162 mm

code	liter	height (mm)
880456	3,4	200
880463	2,4	150
880470	1,6	100
880487	1,0	65



880555

**STORAGE CONTAINER GASTRONORM 1/9**  
- 176x108 mm

code	liter	height (mm)
880555	1,0	100
880562	0,6	65

**GASTRONORM LID**

- Suitable for all Hendi polypropylene Gastronorm containers, including HACCP storage containers

code	mm
880609	GN 1/1 - 530x325
880616	GN 1/2 - 325x265
880623	GN 1/3 - 325x176
880630	GN 1/4 - 265x162
880647	GN 1/6 - 176x162
880654	GN 1/9 - 176x108



880623

**LID CLIPS FOR HACCP STORAGE CONTAINERS**

- 12 pcs. in blister pack

code	colour	packed per
880661	red	12
880678	green	12
880685	yellow	12
880692	blue	12
880869	purple	12



880692

880661

880678

880685

880869

**HORECA MARKERS**

- 2 pieces on blistercard  
- For writing on food containers  
- Erasable

code	packed per
871546	2

871546



# FOOD ALLERGY

When preparing food for customers with food allergies it's important to prevent cross contamination. With the new purple addition to the HACCP colours you now have tools to safely produce meals for allergic people.



880050



880159



880258

**STORAGE CONTAINER GASTRONORM 1/1**  
– 530x325 mm

code	liter	height (mm)
880050	28	200
880067	21	150
880074	14	100
880036	9	65

**STORAGE CONTAINER GASTRONORM 1/2**  
– 325x265 mm

code	liter	height (mm)
880159	12,5	200
880166	9,5	150
880173	6,5	100

**STORAGE CONTAINER GASTRONORM 1/3**  
– 325x176 mm

code	liter	height (mm)
880258	7,8	200
880265	5,7	150
880272	4,0	100
880289	2,5	65



880371



880456



880555

**STORAGE CONTAINER GASTRONORM 1/4**  
– 265x162 mm

code	liter	height (mm)
880357	5,5	200
880364	4,0	150
880371	2,8	100
880388	1,8	65

**STORAGE CONTAINER GASTRONORM 1/6**  
– 176x162 mm

code	liter	height (mm)
880456	3,4	200
880463	2,4	150
880470	1,6	100
880487	1,0	65

**STORAGE CONTAINER GASTRONORM 1/9**  
– 176x108 mm

code	liter	height (mm)
880555	1,0	100
880562	0,6	65





**NEW!**



881705



**GASTRONORM LID PURPLE**

- Suitable for all Hendi polypropylene Gastronorm containers, including HACCP storage containers

code	mm
881705	GN 1/1 - 530x325
881712	GN 1/2 - 325x265
881729	GN 1/3 - 325x176
881736	GN 1/4 - 265x162
881743	GN 1/6 - 176x162
881750	GN 1/9 - 176x108

826164



826065



**CUTTING BOARD HACCP GASTRONORM**

- One side smooth and other side with groove.  
- Can be cleaned in professional dishwashers (short program).

code	colour	mm
826065	purple	GN 1/1 - 530x325x(H)15
826164	purple	GN 1/2 - 265x325x(H)12

825570



825662



**CUTTING BOARD HACCP**

- Can be cleaned in professional dishwashers (short program).

code	colour	mm
825662	purple	600x400x(H)18
825570	purple	450x300x(H)12,7



880869

**LID CLIPS FOR HACCP STORAGE CONTAINERS**

- 12 pcs. in blister pack

code	colour	packed per
880869	purple	12



842775



**COOK'S KNIFE**

code	blade/knife length (mm)	thickness (mm)
842676	180/320	2,5
842775	240/385	2,5

**NEW!**

842270



842171



**NEW!**

**UNIVERSAL KNIFE**



code	model	blade/knife length (mm)	thickness (mm)
842270	short model	90/190	1,2
842171	serrated	100/205	1,2



**NEW!**

**CARVING KNIFE**



code	blade/knife length (mm)	thickness (mm)
842478	150/280	2,5



### CUTTING BOARD HACCP



- Made of polyethylene HDPE 500.
- Meets HACCP standards.
- Both sides suitable for cutting.
- Can be cleaned in professional dishwashers (short program).



### CUTTING BOARD HACCP 600X400X(H)18

code	colour	for
825600	white	cheese, bread
825617	red	raw meat
825624	blue	fish
825631	green	fruits, vegetables
825648	brown	cooked meat
825655	yellow	raw poultry
825662	purple	allergens

### CUTTING BOARD HACCP 450X300X(H)12,7

code	colour	for
825518	white	cheese, bread
825525	red	raw meat
825532	blue	fish
825549	green	fruits, vegetables
825556	brown	cooked meat
825563	yellow	raw poultry
825570	purple	allergens

### CUTTING BOARD RACK

- For 6 cutting boards up to 20 mm thick.



code	mm
826201	303x211x(H)205

826201



## CUTTING BOARD HACCP

- Made of polyethylene HDPE 500.
- Meets HACCP standards.
- Both sides suitable for cutting.



Side with groove

Smooth side

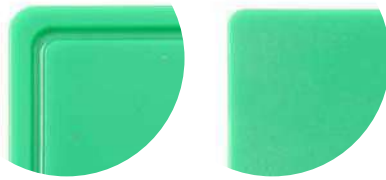

325



## CUTTING BOARD HACCP GASTRONORM 1/1

- One side smooth and other side with groove.
- Dimensions: 530x325x(H)15 mm

code	colour	for
826003	white	cheese, bread
826010	red	raw meat
826027	blue	fish
826034	green	fruits, vegetables
826041	brown	cooked meat
826058	yellow	raw poultry
826065	purple	allergens

## CUTTING BOARD HACCP GASTRONORM 1/2

- One side smooth and other side with groove.
- Dimensions: 265x325x(H)12 mm

code	colour	for
826102	white	cheese, bread
826119	red	raw meat
826126	blue	fish
826133	green	fruits, vegetables
826140	brown	cooked meat
826157	yellow	raw poultry
826164	purple	allergens

Groove to prevent leaking







**NEW!**



**CUTTING BOARD HACCP GASTRONORM 1/1**

- Dimensions: 530x325x(H)10 mm

code	colour	for
826607	<input type="checkbox"/> white	cheese, bread
826614	<input checked="" type="checkbox"/> red	raw meat
826621	<input checked="" type="checkbox"/> blue	fish
826638	<input checked="" type="checkbox"/> green	fruits, vegetables
826645	<input checked="" type="checkbox"/> brown	cooked meat
826652	<input checked="" type="checkbox"/> yellow	poultry

**NEW!**



**CUTTING BOARD HACCP GASTRONORM 1/2**

- Dimensions: 265x325x(H)9 mm

code	colour	for
826706	<input type="checkbox"/> white	cheese, bead
826713	<input checked="" type="checkbox"/> red	raw meat
826720	<input checked="" type="checkbox"/> blue	fish
826737	<input checked="" type="checkbox"/> green	fruits, vegetables
826744	<input checked="" type="checkbox"/> brown	cooked meat
826751	<input checked="" type="checkbox"/> yellow	poultry



826300

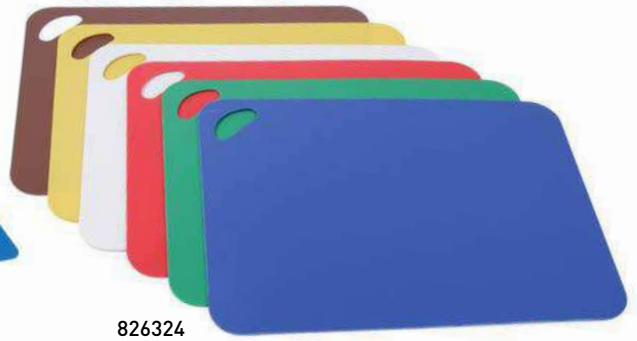

826324



Anti-slip surface



**HACCP CUTTING MAT SET - 6 PIECES**

- Colour coded set of 6 mats to facilitate kitchen hygiene.
- White, red, blue, green, brown, yellow.
- Flexible, allowing easy pouring of cut products.
- Lightweight and easy to store and transport.

code	mm
826300	380x305x(H)1,4
826331	300x200x(H)1,4

**NEW!**

**HACCP ANTI-SLIP CUTTING MAT SET - 6 PIECES**

- Colour coded set of 6 anti-slip mats to facilitate kitchen hygiene.
- White, red, blue, green, brown, yellow.
- Flexible, allowing easy pouring of cut products.
- Lightweight and easy to store and transport.

code	mm
826324	305x455x(H)2

**ANTI-SLIP MAT**

- Multifunctional anti-slip mat.
- Made of PVC foam.
- Easy to cut to size.
- Wash by hand at 40°C.
- Not suitable for direct food contact.

code	mm
598047	1500x300



598047





# NEW!



## CUTTING BOARD WITH HANDLE

- Made of polyethylene HDPE.
- Both sides suitable for cutting.

code	mm	colour
826348	250x150x(H)10	<input type="checkbox"/> white
826478	250x150x(H)10	<input checked="" type="checkbox"/> black
826355	300x200x(H)10	<input type="checkbox"/> white
826485	300x200x(H)10	<input checked="" type="checkbox"/> black



826355

826348

## CUTTING BOARD WOOD

506912



506905



505205



505007



## CUTTING BOARD

- Rubberwood
- With handles

code	mm
506912	GN 1/2 265x325x(H)45
506905	GN 1/1 530x325x(H)45

## CARVING BOARD

- Solid beech wood
- Grooved

code	mm
505205	390x230x(H)16

## BREAD BOARD

- Solid beech wood

code	mm
505007	340x200x(H)14



505106

side with groove



505403

ribbed side

## CUTTING BOARD WITH GRIP

- Solid beech wood

code	mm
505106	390x160x(H)13

## BAGUETTE BOARD

- Solid beech wood
- Combined model, 1 side grooved and 1 side ribbed

code	mm
505403	530x325x(H)18



505502

## BAGUETTE BOARD

- Wooden with removable grid

code	mm
505502	475x322



removable grid  
- easy to clean



## KNIVES PROFI LINE



- All knives are precision hot drop forged from a single blank of high carbon German stainless steel. The specialized Chromium-Molybdenum-Vanadium surgical alloy steel X50CrMoV15 guarantees the following characteristics:
  - razor sharp
  - long-lasting cutting edge
  - easily restorable edge
  - high stain resistance
- Some 50 major manufacturing steps are required to produce each knife. Traditional skills and precision machinery continue the grinding and polishing operations until the final cutting edge is applied at the most appropriate blade angle. The handle combines balance, safety, heft and control with an exclusive look.
- Each knife is individually packed in a PET presentation blister.

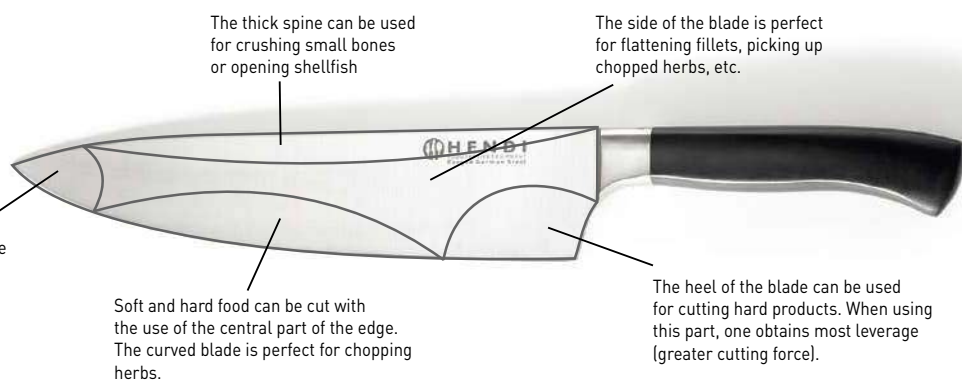

### COOK'S KNIFE

code	thickness (mm)	blade/knife length (mm)
844205	3,3	250/385

### COOK'S KNIFE

code	thickness (mm)	blade/knife length (mm)
844212	3,3	200/335

### UTILITY KNIFE

code	thickness (mm)	blade/knife length (mm)
844250	2	150/265



### CARVING KNIFE

code	thickness (mm)	blade/knife length (mm)
844311	2,7	250/380



### CARVING KNIFE

code	thickness (mm)	blade/knife length (mm)
844304	2,6	200/330



### BONING KNIFE

- Flexible

code	thickness (mm)	blade/knife length (mm)
844267	2	150/270



### PARING KNIFE

code	thickness (mm)	blade/knife length (mm)
844236	1,9	90/195



### KNIFE SHARPENER DIAMOND

- Diamond coating

code	blade/knife length (mm)
844403	310/445



### HAM/SALMON KNIFE

- Half flexible

code	thickness (mm)	blade/knife length (mm)
844328	2,6	300/430



### BREAD KNIFE

code	thickness (mm)	blade/knife length (mm)
844298	2,4	215/340



### BREAD KNIFE

- Offset

code	thickness (mm)	blade/knife length (mm)
844281	2,4	215/340



### CLEAVER

- Plain version

code	thickness (mm)	blade/knife length (mm)
844342	4	170/295



### CLEAVER

- Granton indentations

code	thickness (mm)	blade/knife length (mm)
844335	2,5	170/295



### SANTOKU KNIFE

- Granton indentations

code	thickness (mm)	blade/knife length (mm)
844274	3	180/310



### CARVING FORK

code	thickness (mm)	blade/knife length (mm)
844229	9	150/285



**KNIVES KITCHEN LINE**



- Made of one piece of hard, forged chrome molybdenum steel.
- Due to the highest quality of the workmanship, Hendi knives are durable and resistant to corrosion with long-lasting sharpness of the blade.
- A unique design of the handle prevents depositing of food residues in the handle/blade transition area.
- Each knife is individually packed in a PET presentation blister.
- With safe, profiled black POM plastic handle.

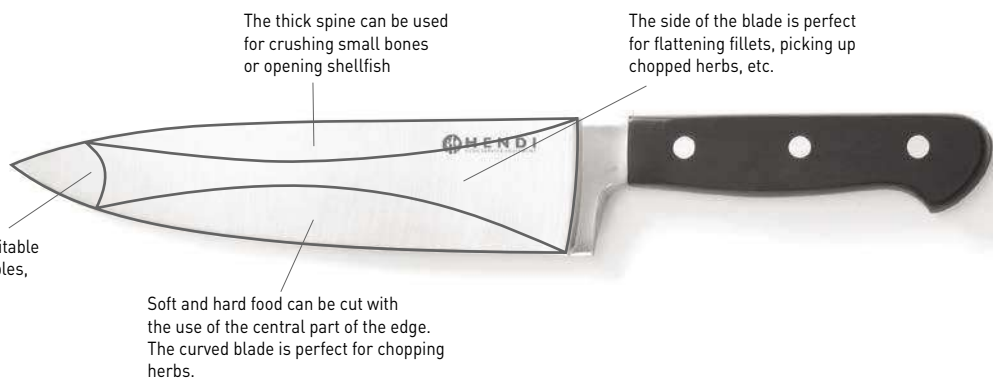

**COOK'S KNIFE**

code	blade/knife length (mm)
781319	200/340



**COOK'S KNIFE**

code	blade/knife length (mm)
781357	150/295



**CARVING KNIFE**

code	blade/knife length (mm)
781340	200/340



**BONING KNIFE**

code	blade/knife length (mm)
781371	150/285





### BREAD KNIFE

code	blade/knife length (mm)
781333	230/345



### KITCHEN KNIFE

code	blade/knife length (mm)
781388	125/240



### PARING KNIFE

code	blade/knife length (mm)
781395	90/200



### POULTRY SHEARS

code	blade/knife length (mm)
781401	140/250



### CARVING FORK

code	blade/knife length (mm)
781364	175/290



### CLEAVER

code	blade/knife length (mm)
781302	180/300



### HAM/SALMON KNIFE

code	blade/knife length (mm)
781326	215/380



### KNIFE SHARPENER

code	blade/knife length (mm)
781418	Ø10x230/360

### KNIFE MAGNET WITH HOOKS

- With 2 magnetic strips



code	part	length (mm)
820209	3 hooks	300
820308	5 hooks	450
820407	6 hooks	600





**NEW!**



**9-PIECE KNIVES SET**

- Made of one piece of hard, stainless steel 3CR14
- Handle made of stainless steel 430 with rubber coating
- Due to the highest quality of the workmanship, knives are durable and resistant to corrosion with long-lasting sharpness of the blade
- With safe, profiled handle
- Included:
  - 1 - Meat fork curved -320 mm
  - 2 - Knife sharpener -340 mm

- 3 - Santoku knife -336 mm
- 4 - Cook's knife -370 mm
- 5 - Cook's knife -330 mm
- 6 - Ham/salmon knife -331 mm
- 7 - Bread knife -333 mm
- 8 - Boning knife -285 mm
- 9 - Paring knife -193 mm
- 10 - Convenient carrying case

code

**975770**

Convenient carrying case



**JAPANESE KNIVES**

- Top end series of drop forged knives
- Made of the high carbon steel alloy X50CrMoV15
- Produced in 50 major manufacturing steps
- Traditional wooden handle
- Each knife is individually packed in a PET presentation blister.
- Limited edition, specially made for Hendi.

code		blade/knife length (mm)	thickness (mm)
845059	1 Knife ‚Sashimi‘	210/340	4
845042	2 Knife ‚Sashimi‘	240/370	4
845028	3 Knife ‚Nakiri‘	180/325	4
845035	4 Knife ‚Santoku‘	165/295	2

## BLACK - UNIVERSAL

- Polypropylene handle in accordance with HACCP guidelines.
- Each knife is individually packed in a PET blister.



### UNIVERSAL KNIFE

- Short model

code	thickness (mm)	blade/knife length (mm)
842201	1,2	90/190

### UNIVERSAL KNIFE

- Serrated

code	thickness (mm)	blade/knife length (mm)
842102	1,2	100/205

### CARVING KNIFE

code	thickness (mm)	blade/knife length (mm)
842409	2,5	150/280

### COOK'S KNIFE

code	thickness (mm)	blade/knife length (mm)
842607	2,5	180/320

### COOK'S KNIFE

code	thickness (mm)	blade/knife length (mm)
842706	2,5	240/385

### HAM/SALMON KNIFE

code	thickness (mm)	blade/knife length (mm)
842904	1,7	350/490

### BREAD KNIFE

code	thickness (mm)	blade/knife length (mm)
843000	1,5	250/385

### BREAD KNIFE

code	thickness (mm)	blade/knife length (mm)
843109	1,5	300/430

### BUTCHER'S KNIFE

code	thickness (mm)	blade/knife length (mm)
844427	2,5	200

### BUTCHER'S KNIFE

code	thickness (mm)	blade/knife length (mm)
844410	2,5	250

### BONING KNIFE

code	thickness (mm)	blade/knife length (mm)
844441	1,8	150

### FILLET KNIFE

code	thickness (mm)	blade/knife length (mm)
844434	1,8	150

### KNIFE SHARPENER

code	thickness (mm)	blade/knife length (mm)
781418	Ø10	230/360



### BROWN - COOKED MEAT

- Polypropylene handle in accordance with HACCP guidelines.
- Each knife is individually packed in a PET blister.



code		blade/knife length (mm)	thickness (mm)
842669	1 Cook's knife	180/320	2,5
842799	2 Cook's knife	240/385	2,5
842966	3 Ham/salmon knife	350/490	1,7



Ergonomic non slip handle



Granton indentations for non-stick cutting



### RED - RAW MEAT

- Polypropylene handle in accordance with HACCP guidelines.
- Each knife is individually packed in a PET blister.

code		blade/knife length (mm)	thickness (mm)
842423	1 Carving knife	150/290	2,5
842522	2 Filleting knife	150/300	0,9
842621	3 Cook's knife	180/320	2,5
842720	4 Cook's knife	240/385	2,5
842928	5 Ham/salmon knife	350/490	1,7



Ergonomic non slip handle



Granton indentations for non-stick cutting

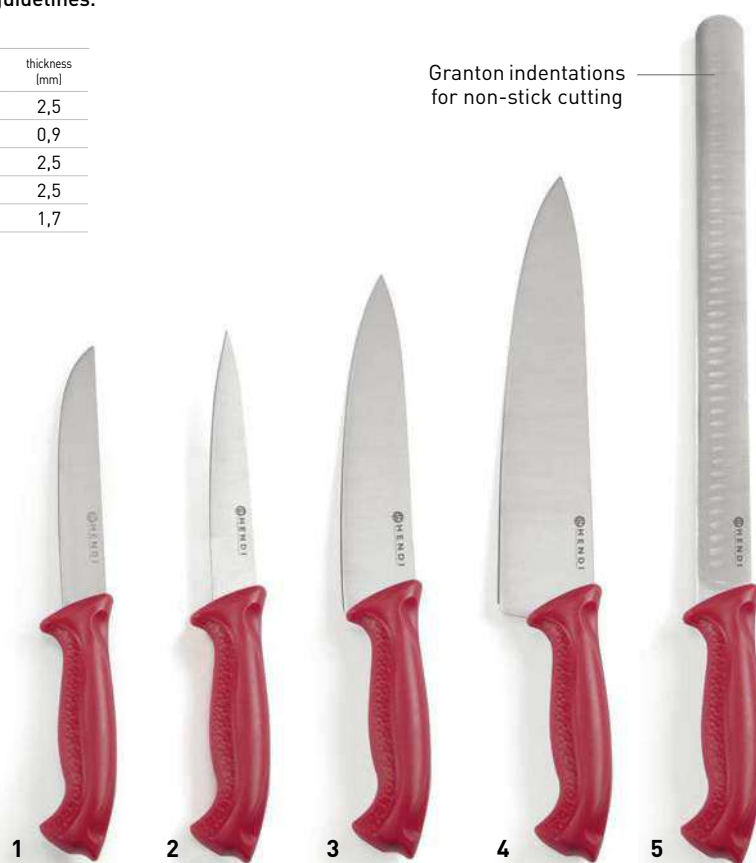



## YELLOW - POULTRY

- Polypropylene handle in accordance with HACCP guidelines.
- Each knife is individually packed in a PET blister.



code			blade/knife length (mm)	thickness (mm)
842539	1	Filleting knife	150/300	0,9
842638	2	Cook's knife	180/320	2,5
842737	3	Cook's knife	240/385	2,5



Ergonomic non slip handle



1



2



3



## BLUE - FISH

- Polypropylene handle in accordance with HACCP guidelines.
- Each knife is individually packed in a PET blister.

code			blade/knife length (mm)	thickness (mm)
842546	1	Filleting knife	150/300	0,9
842645	2	Cook's knife	180/320	2,5
842744	3	Cook's knife	240/385	2,5



Ergonomic non slip handle



1



2



3





## WHITE - CHEESE & BREAD

- Polypropylene handle in accordance with HACCP guidelines.
- Each knife is individually packed in a PET blister.



code		blade/knife length (mm)	model	thickness (mm)	
842256	1	Universal knife	90/190	short model	1,2
842355	2	Universal knife	130/230	long model	1,2
842553	3	Filleting knife	150/300		0,9
842652	4	Cook's knife	180/320		2,5
842751	5	Cook's knife	240/385		2,5
843055	6	Bread knife	250/385		1,5
843154	7	Bread knife	300/430		1,5



Ergonomic non slip handle



Granton indentations for non-stick cutting



## GREEN - FRUITS & VEGETABLES

- Polypropylene handle in accordance with HACCP guidelines
- Each knife is individually packed in a PET blister

code		blade/knife length (mm)	model	thickness (mm)	
842218	1	Universal knife	90/190	short model	1,2
842119	2	Universal knife	100/205	serrated	1,2
842317	3	Universal knife	130/230	long model	1,2
842614	4	Cook's knife	180/320		2,5
842713	5	Cook's knife	240/385		2,5



Ergonomic non slip handle



Granton indentations for non-stick cutting



## PARING KNIVES, SET OF 6 COLOURS



### PARING KNIVES

- Set with 6 different colours: white, red, blue, green, black and yellow
- Made of rolled steel

code	blade/knife length (mm)
842003	75/175



### PARING KNIVES

- Set with 6 different colours: white, red, blue, green, black and yellow
- Made of rolled steel

code	blade/knife length (mm)
842010	90/185

## PARING KNIVES AND PEELERS

- High quality

### PARING KNIFE

- "Made in Germany"



code		blade/knife length (mm)
841105	straight model	75/180
841112	pointed model	87/190
841129	curved model	60/165



841105 841112 841129 841136

### TOMATO KNIFE

- Polypropylene handle
- "Made in Germany"



code	blade/knife length (mm)
841136	110/210

### PARING KNIFE WITH WOODEN HANDLE

- "Made in Germany"



code	blade/knife length (mm)
841020	60/165



841020

### SPEED PEELER

- Transverse model.



code	blade/knife length (mm)
841228	50/110



841228

### PEELER

- Pendulum model



code	blade/knife length (mm)
841235	50/150



841235





**LEMON ZESTER**

code	mm
856031	155



**GRAPEFRUIT KNIFE**

code	mm
856185	110/215



**VEGETABLE CORER**

code	mm
856086	110/220



**CITRUS PEELER**

code	mm
856055	180

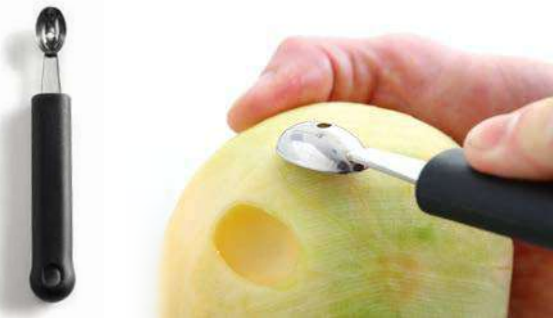

**MELON SCOOP OVAL**

code	mm
856017	Ø26x165



**MELON SCOOP SERRATED**

code	mm
856024	serated Ø22x155



**MELON SCOOP DOUBLE**

code	mm
856000	Ø22-25x165



**CHANNEL KNIFE**

code	mm
856048	150





**PIZZA SLICER**

code	mm
617014	Ø100x230



**DOUGH CUTTER SERRATED BLADE**

code	mm
856154	Ø60x180



**BUTTER CURLER**  
- Serrated

code		mm
856192	serrated	200



**SPREADER - SERRATED**

code	mm
855768	100x85x225



**POTATO PEELER**

code	mm
856178	175



**DECORATION KNIFE**

code	serated 90 mm	mm
856062		200



**TOMATO KNIFE OFFSET**

code	serated 110 mm	mm
856253		230



**APPLE CORER**

code	diameter/length Ø 20 mm / 100 mm	mm
856079		215





**CHEESE SLICER**

code	mm
856208	205

**CHEESE SLICER FOR SOFT CHEESE**

code	mm
856215	160

**CHEESE GRATER**

code	mm
856222	170x75



**NEW!  
MODEL!**



**CHEESE KNIFE FOR SOFT CHEESE**

code	mm
856246	160/270



**NEW!  
MODEL!**



**CHEESE KNIFE FOR HARD CHEESE**

code	mm
856239	130/260

**GARNISHING TOOLS**



856291



**DECORATION TOOLSET - 6 PIECES**

- Holdall with:
- Melon scoop double
- Apple corer 20mm
- Decoration knife
- Melon scoop serated
- Lemon zester
- Channel knife

code
856291

## MINCING KNIVES & SCISSORS



556641

**NEW!**



### CUT RESISTANT GLOVES

- Offers protection for handling sharp blades in the professional kitchen, like kitchen knives.
- The mix of HPPE, polyester fibres and nylon makes these gloves durable and comfortable.
- Level 4 cut resistance.
- Level 3 abrasion resistance.

code	packed per
556641	2



### MINCING KNIFE

code		mm
844366	double blade	230
844359	single blade	230

### POULTRY SHEARS

- High carbon steel
- Softgrip

code	mm
856314	240

### KITCHEN SCISSORS

- Detachable - easy to clean
- Softgrip

code	mm
856307	195

### KITCHEN SCISSOR SOFTGRIP

- Detachable - easy to clean
- With softgrip
- Bottle opener integrated



code
856284



856277

**NEW!**

### KNIFE CARRYING CASE

- Compact case with plenty of room for knives and accessories.
- Space for 10 knives (max length 450 mm), knives are held in place by elastic.
- The knives are protected by additional covers which are held in place by either a zipper or velcro, this ensures that knives don't make direct contact when the case is folded to a close.
- With 1 big pocket for note pads, 4 small pockets for business cards and space for 3 pens or other small accessories.
- The shoulder strap length can be adjusted between 770mm and 1270 mm.
- Dimensions unfolded: 510x650 mm

code	mm
856277	510x170x(T)50



**NEW!**



**ABS**  
plastic



see movie

**KNIFE SHARPENER**

- Suitable for quick and easy sharpening of knives
- Sand paper easy to change
- Suitable for all sorts of meat, fish, vegetable and fruit knives

code	mm	V	W
224403	310x110x(H)110	230	50
224410	Sand paper replacement part		



224403



see movie

820605

**PP**  
polypropylene

**KNIFE SHARPENER**

- With finger protection.
- Reversible double sharpening blades made of carbide.

The sharpening elements made of tungsten carbide, one of the toughest materials available.

code	mm
820605	140



**ABS**  
plastic



820612

**KNIFE SHARPENER**

- Ergonomic handle and non-slip base provide safety and comfort.
- 3 functions for sharpening all kinds of knives, even ceramic knives.
- Do not use to sharpen serrated blades or scissors.

code	mm
820612	200x46x(H)75

**CERAMIC:** crossed electroplated rods for ceramic knives.

**COARSE:** carbide sharpener for a precision edge every time.

**FINE:** crossed ceramic rods for professional grade edge honing.







**POTATO MASHERS**

- Heavy duty solid model.

code	mm
693254	Ø118x(H)306
693261	Ø118x(H)456

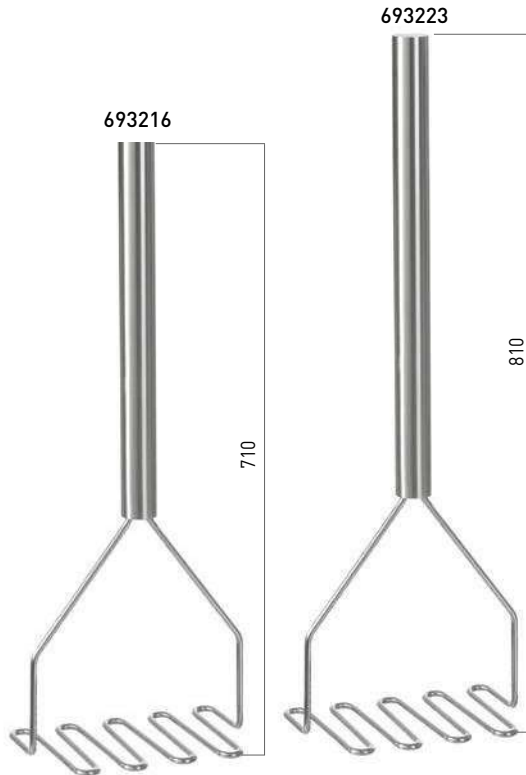

**POTATO MASHERS**

- Heavy duty solid model.



code	mm
693216	200x130x(H)710
693223	200x130x(H)810

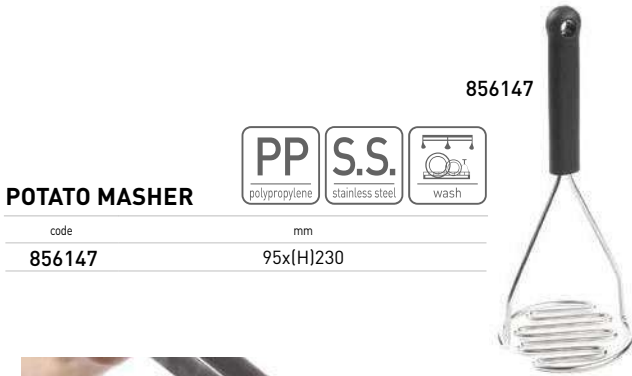

**POTATO MASHER**



code	mm
856147	95x(H)230



**POTATO RICER**

code	mm
515105	300x110

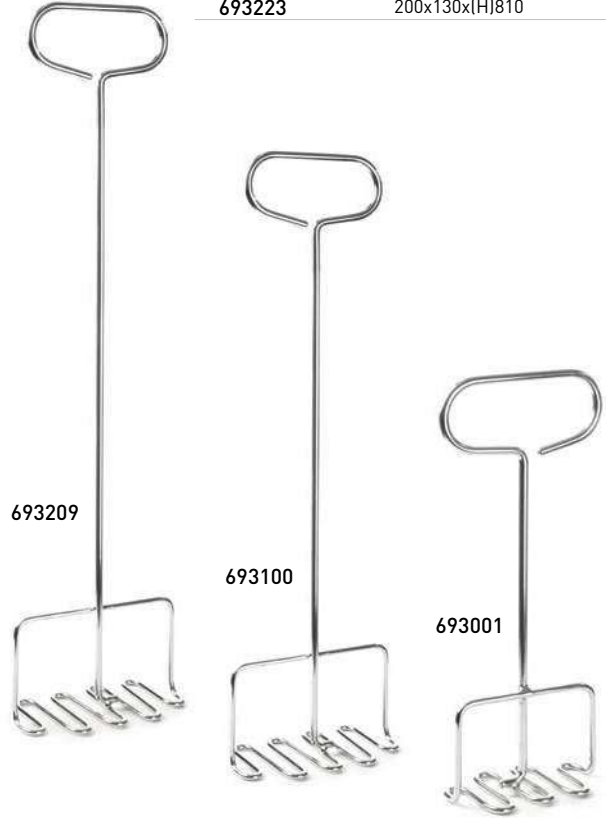

**POTATO MASHERS**

- Heavy duty solid model.



code	mm
693001	130x(H)355
693100	180x(H)600
693209	180x(H)770



690000



**CAN OPENER KITCHEN LINE**

- Including table mounting device
- Suitable for cans up to 335 mm



code	mm
690000	550



856116



**CAN OPENER**

code	mm
856116	200



**TAB GRABBER**

- Glossy aluminium
- Mounting by screws or by adhesive



513705

code	mm
513705	600
513712	915

**NEW!**



570715

**GARLIC PRESS**



code	mm
570715	175x30



856123

**GARLIC PRESS**

- Easy to clean
- Two removable grids



code	mm
856123	180x25



570104



**EGG SLICER - RECTANGULAR**

code	mm
570104	130x85



570012



**EGG SLICER - OVAL**

code	mm
570012	120x115

## SALAD SPINNER



Removable inner basket



222560



### SALAD SPINNER

- Ideal for drying large amounts of vegetables and fruits after washing.
- With an easy to use water draining system.
- Removable inner basket.
- Not available in France.

code	liter	mm
222553	12	Ø335x(H)430
222560	25	Ø430x(H)530



570906

### ONION GOGGLES

- Wear the goggles during the cutting of onions to prevent teary eyes.

code	packed per
570906	1







Extremely sharp,  
laser cut rasps



856352



856369



856376



856321



856338



856345

**RASPS**

- Laser cut blades, high precision and extremely sharp.

code		mm
856352	Fine	35x220 / (L)390
856369	Coarse	35x220 / (L)390
856376	Ribbon	35x220 / (L)390

**RASPS**

- Laser cut blades, high precision and extremely sharp.

code		mm
856321	Coarse	65x135 / (L)315
856338	Ribbon	65x135 / (L)315
856345	Shaver	65x135 / (L)315



443002

**GRATER, FOUR-SIDED**

code	mm
443002	90x65x(H)200





### VEGETABLE CUTTER V-TYPE DOUBLE BLADED

- Made of stainless steel and black ABS.
- V-shaped main slicing blade, crinkled secondary slicing blade.
- Easy to adjust the slicing thickness of both blades.
- Foldable stand with rubber feet.
- Comes with two extra blades for julienne or french fries, 6 or 9 mm wide.
- Storage box included to safely store the blades.
- Polypropylene product holder with metal pins.

code	mm
222676	530x165x(H)203



222676

### VEGETABLE CUTTER V-TYPE

- Made of hard black PP and ABS
- Including 5 high quality stainless steel blades
- Foldable stand with rubber feet
- V-shaped main cutting blade
- Blades for julienne or french fries, 6 or 9 mm wide
- Adjustable slice thickness from 1-9 mm
- Product holder with metal pins
- Height 140 mm (with raised support)

code	mm
222614	130x335x(H)75



V-shaped cutting blade for fast slicing

222614



### VEGETABLE CUTTER

- 2 blades for slicing (1 crinkle blade) and 3 blades for jullienne (5, 7, 10 mm).
- Sliding product holder and storage box for blades.
- With non-slip stand.

code	mm
222652	395x125x(H)200



Comes complete with product holder, 5 blades and blade storage box



222652



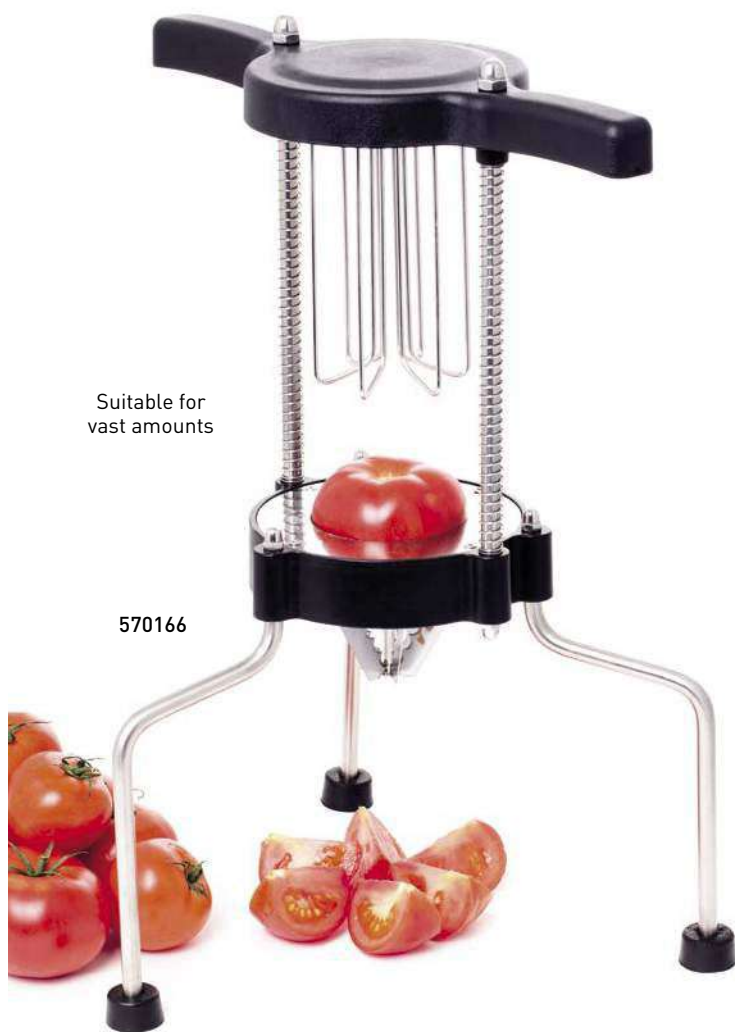

Suitable for vast amounts

570166



**TOMATO CUTTER**

- Cuts tomatoes and other soft fruits into wedges.
- The sturdy legs with non slip feet leave room to place a bowl under the blades.
- Fitted with 6 serrated stainless steel blades.
- The pusher is spring loaded and has 2 handles.

code	mm
570166	360x300x(H)380



**TOMATO SLICER**

- Only for cutting tomato or soft vegetables/fruits.
- Slice thickness ± 5 mm.
- Easy to clean.
- With suction cup feet.
- Screw tightening tools such as Hex socket wrench not included.

570159

With suction cup feet

Fitted with hand protection



code	mm
570159	432x202x(H)210



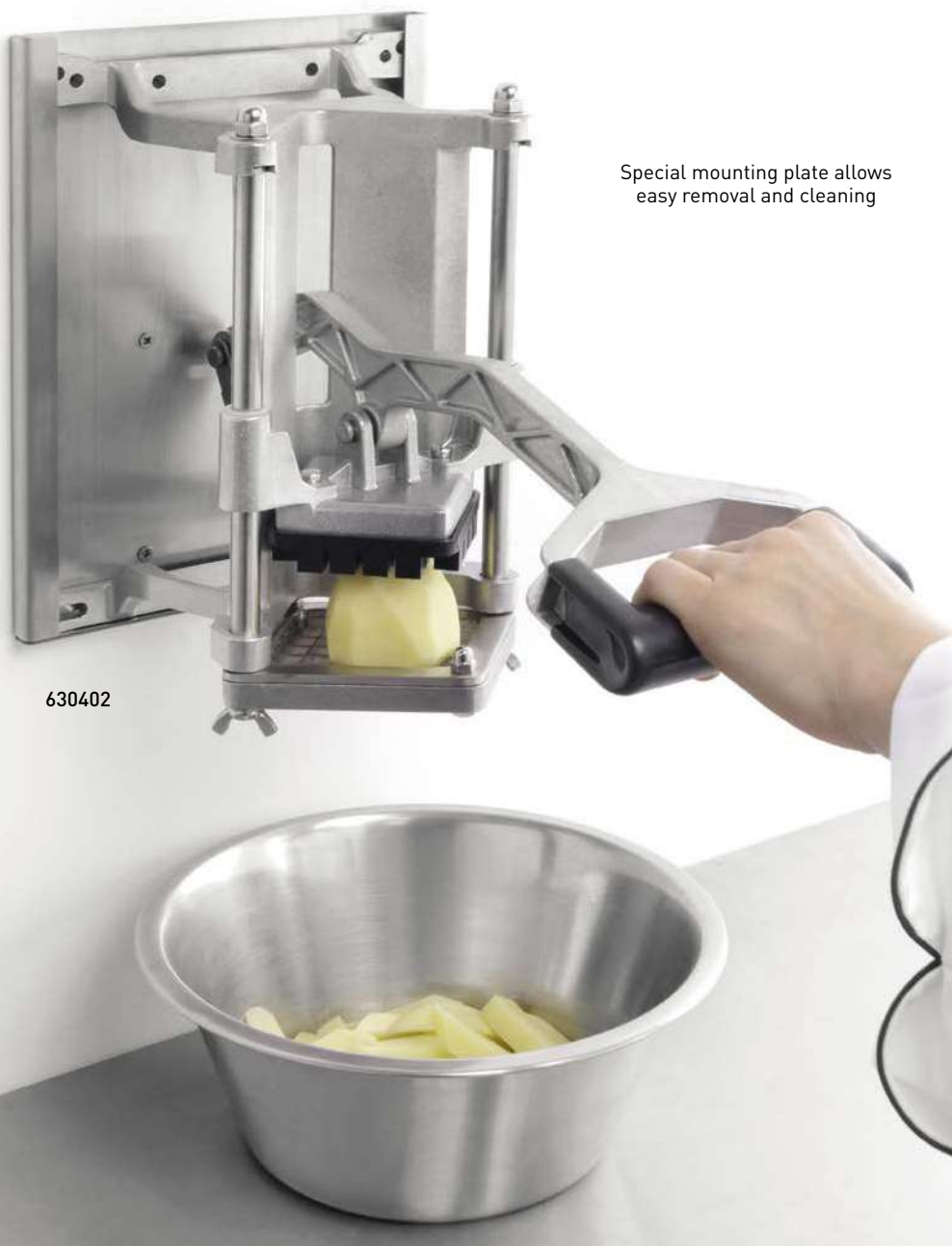

630402

Special mounting plate allows easy removal and cleaning



**NEW!**

630419



### FRENCH FRIES CUTTER

- Knives made of stainless steel.
- Comes with 4 blades: 6, 9 and 13 mm, as well as a knife for 8 parts.
- Mountable to working table or wall.
- Handle covered by plastic for easier pressing.
- Stainless steel mounting plate allows easy removal and cleaning.
- With rubber feet to hold firmly when using on table.

code	mm
630402	430x168x(H)290
630419	Knife for 11 mm thick fries

**NEW!**



With suction cup feet





505694

Reinforced base

**WOODEN BUTCHER BLOCK ON WOODEN BASE**

- Made of beech wood
- Height wooden base: 700 mm

code	mm
506011	500x400x(H)200
505694	500x400x(H)150
505625	400x400x(H)150
505618	400x400x(H)110



505656

505670

**POLYETHYLENE BUTCHER BLOCK**

- Made of polyethylene HDPE500.
- Reinforced frame made of stainless steel.



code		mm
505687	set	500x400x(H)800
505663	block	500x400x(H)80
505656	block	500x400x(H)50
505670	stand	500x400x(H)750



505632

Oiled work surface

Varnished sides

**WOODEN BUTCHER BLOCK WITHOUT BASE**

- Made of beech wood

code	mm
505649	500x400x(H)200
505632	500x400x(H)150



513538

**BUTCHER'S HOOK - SET OF 4**

code	mm
513538	90x4
513545	110x5
513552	130x5
513569	150x6

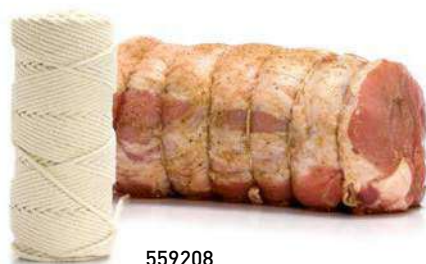

559208

**ROULADE STRING**

- Spool with 100g of string
- Made of unbleached cotton
- About 85 m

code	packed per
559208	1



## MEAT TENDERIZERS



513019



### MEAT TENDERIZING HAMMER

- Sturdy handle, flat surface for meat, fish and poultry.
- Extra heavy duty, weighs 750 grams

code	mm
513019	Ø93x(H)290



Spiked surface  
for pork and beef



Plain surface for  
fish and poultry



513002

### MEAT TENDERIZING HAMMER

- Firm grip
- Spiked surface for pork and beef
- Plain surface for fish and poultry

code	length (mm)
513002	220

### MEAT TENDERIZER PROFI LINE

- Modern and effective tool for meat improvement, the interspaced vertical blades reduce the length of meat fibers.
- Perfectly tenderizes meat by softening the tissue and flattening meat at the same time.
- Marinating time can be reduced by up to 25%, because the surface area of the meat is significantly increased.
- During frying, the subtle perforation will allow sauces poured over the meat to penetrate.
- Soft springs, easier use, better result.

code	type	mm
843451	51 blades	150x42x(H)118



Specially  
designed grip



see movie

843451



51 stainless  
steel blades for  
cutting meat

Wave-shaped tabs  
on the bottom for  
flattening meat





630808



**CHIPS COLANDER STAINLESS STEEL**

- Completely made of stainless steel
- With stainless steel handle
- With removable bottom tray



code	mm
630808	Ø410x(H)170



630006

**CHIPS COLANDER ALUMINIUM**

- Fixed bottom and removable strainer



code	mm
630006	Ø400x(H)170



630303

**MEAT & CHIPS TRAY**



code	mm
630303	470x310x(H)75



630716

**SAUSAGE CUTTER**



code	mm
630716	200

630136



630235



### SALT AND PEPPER SHAKER

- With screw cap



code		mm
630136	Salt shaker	Ø80x(H)175
630235	Pepper shaker	Ø63x(H)100

630105



630204



### SALT AND PEPPER SHAKER

- With screw cap



code		mm
630105	Salt shaker	Ø80x(H)195
630204	Pepper shaker	Ø65x(H)105



632802



### GREASE FILTER FOR DEEP FRYER

- Made of rayon (synthetic silk).

code	packed per	mm
632802	50	254x254

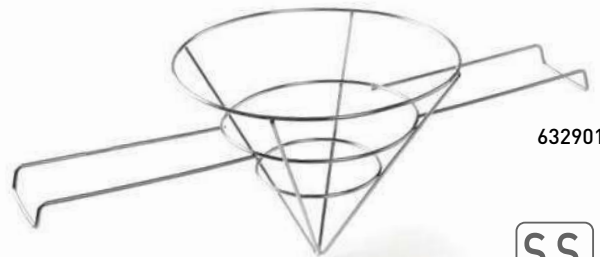

632901

### GREASE FILTER HOLDER FOR DEEP FRYER



code	mm
632901	Ø250x(H)200



196007

### BUCKET

- With lid  
- Suitable as fat storage bucket



code	liter	mm
196007	11,5	Ø290x(H)220

CHIP SCOOPS & SHOVELS



mesh size  
7,5x7,5 mm



**CHIP SCOOP**

- Made of stainless steel with PA handle
- With extra deep scoop

code	mm
640913	Ø240x(L)600
640920	Ø260x(L)600



mesh size  
5x5 mm



**CHIP SCOOP**

- With wire handle

code	mm
640104	Ø100x(L)330
640203	Ø125x(L)420

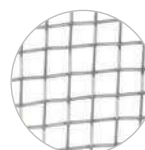

mesh size  
5x5 mm



**CHIP SCOOP**

- With reinforced wire handle

code	mm
640401	Ø160x(L)450
640500	Ø180x(L)470
640609	Ø200x(L)510
640708	Ø220x(L)540
640807	Ø240x(L)550

Full range of the deep fryers on page 164-168





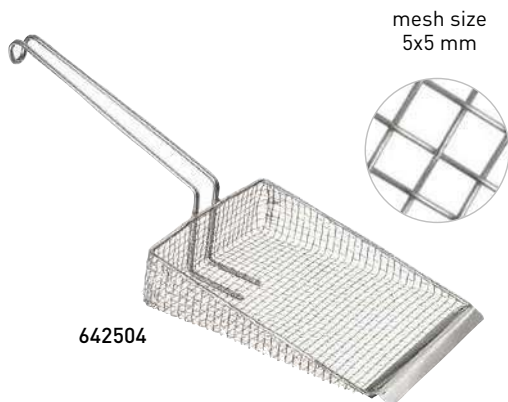

642504

mesh size  
5x5 mm

**CHIPS SHOVEL**

- With 150 mm long wire handle



code	mm
642504	160x210

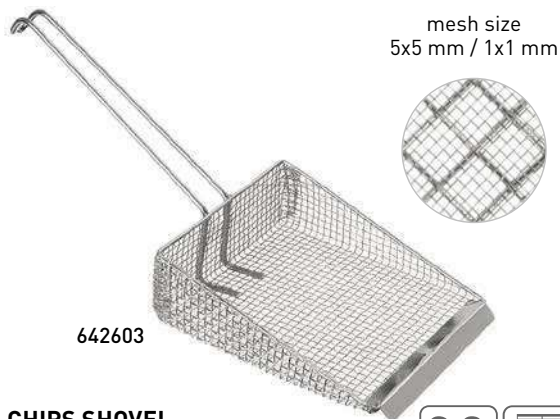

642603

mesh size  
5x5 mm / 1x1 mm

**CHIPS SHOVEL**

- With 225 mm long wire handle  
- Double mesh



code	mm
642603	175x225



642566

**FRENCH FRIES FUNNEL SCOOP**

- Fill opening 70 mm  
- Left and right handed



code	mm
642566	233x205



642559

**FRENCH FRIES FUNNEL SCOOP**

- With detachable handles  
- Fill opening 75 mm  
- Left and right handed



code	mm
642559	200x230



646205

646304

**FAT SKIMMER - FINE MESH**

- With wire handle



code	mm
646205	Ø125x350
646304	Ø150x430



646601

**BIRD'S NEST SHAPED STRAINER**

- With wire handle and fastening clip



code	mm
646601	Ø80/Ø100x395



Graduated



516676



516683



516706



516720

**BUCKET WITH REINFORCED BASE**

- Graduated



code	liter	mm
516676	7	Ø230x(H)245
516683	10	Ø280x(H)245
516706	12	Ø300x(H)310
516720	15	Ø305x(H)310



Wide, reinforced base for stability and hygiene



516713

**LID FOR BUCKET WITH REINFORCED BASE**



code	suitable for	mm
516690	516683	Ø280
516713	516706	Ø300
516737	516720	Ø305



516744



**BUCKET**

code	liter	mm
516744	12	Ø310x(H)300



556719



**CLOTH STRAINER**

- 100% Cotton.  
- Washable up to 95°C.

code		mm
556719	1 on card	700x700



518700



**FUNNEL**

code	mm
518700	Ø120



462904



**OIL JUG**  
- With semi-hinged lid

code	liter	mm
462904	0,3	Ø70x(H)115



624302



**WATER KETTLE - WITH LID**

code	liter	mm
624302	6	Ø245



567616



**FUNNEL**

code	mm
567616	Ø100
567630	Ø127
567654	Ø150



Internal maximum water level indicator



209998

**ELECTRIC KETTLE - 4,2 L**

- Housing and heating element made of stainless steel.
- Handle, lid and base made of polypropylene.
- Concealed heating element protected against scale which extends the lifetime of the heater and the entire kettle.
- Indicator light informs that the heater is on.
- Internal maximum water level indicator.
- Automatic switch-off after boiling.
- Double dry-boil protection.

code	liter	V	W	mm
209998	4,2	230	2000	340x234x(H)290



209981

External water level indicator

**ELECTRIC KETTLE - 1,8 L**

- Housing and heating element made of 304 stainless steel.
- Handle, lid and base made of polypropylene.
- 360-degree swivel base.
- Concealed heating element protected against scale which extends the lifetime of the heater and the entire kettle.
- Indicator light informs that the heater is on.
- External water level indicator.
- Internal maximum water level indicator.
- Automatic switch-off after boiling.
- Double dry-boil protection.
- Only suitable for boiling water, boiling other liquids will damage the appliance.

code	liter	V	W	mm
209981	1,8	230	1800	221x163x(H)249



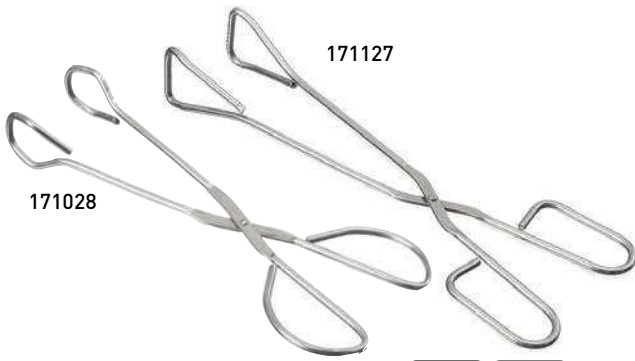

171028

171127



**SERVING TONGS**

code	packed per	length (mm)
171028	2	240
171127	2	300



171417

171516



**SERVING TONGS CURVED**

code	length (mm)
171417	240
171516	300



171318

171325

171301

**SERVING TONGS**

- With heat resistant silicone tongs
- Soft-grip with lock



code	length (mm)
171301	240
171318	300
171325	400







Solid design



**SALAD TONGS**

- With fastening clip.  
- Solid design.



code	length (mm)
171707	250
171806	300
171905	400



**NEW!**

**SERVING TONGS HACCP**

- Handle covered with coloured PVC.



code	colour	length (mm)
171837	red	250
171844	blue	250
171875	green	250
171882	purple	250
171899	yellow	250



**SERVING TONGS**

- With black PVC insulated handles.

code	length (mm)
171752	250
171851	300





680025



680063



680124



680087

680117



680100



### MULTIPURPOSE TWEEZERS

- Suitable for e.g. turning deep frying products.

code	length (mm)
680018	300
680025	230
680032	215
680049	160

### TWEEZERS, CURVED

code	length (mm)
680056	305
680063	240
680070	160

### TWEEZER WITH ROUND HEAD

code	length (mm)
680124	150

### SUSHI TWEEZERS

code	length (mm)
680087	210
680094	160

### FISH BONE TWEEZERS

code	length (mm)
680117	120
680100	130



524008



524039

**NEW!**

### UNIVERSAL TONGS

- With fastening clip.  
- Detachable.



code	length (mm)
524008	280

### UNIVERSAL TONGS WITH TEFLON COATING

- With fastening clip.

code	length (mm)
524039	280

LADLES & TURNERS, HEAT RESISTANT



563311

563304

COOKING SPOON

code		mm
563304	open	48x(L)300
563311	closed	48x(L)300



563335

563328

TURNER

code		mm
563335	slotted	70x(L)310
563328	closed	70x(L)310



563342

SPATULA

code	mm
563342	80x(L)315



563359

ROASTING SHOVEL

code	mm
563359	78x(L)300



563373

SKIMMER

code	mm
563373	Ø120x(L)320



563366

SOUP LADLE

code	mm
563366	100x80x250



563380

SPAGHETTI SPOON

code	mm
563380	73x40x(L)305



**SCRAPERS & TURNERS**



**SCRAPER**  
- With wooden handle.



code	mm
855119	118x100x(L)251



**SCRAPER**

code	mm
855713	80x108x(L)251

**GRIDDLE SCRAPERS**



**HAMBURGER TURNER**  
- With wooden handle

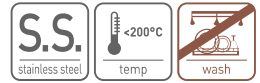

code	mm
855508	120x75x(L)280
855607	150x110x(L)305



**HAMBURGER TURNER**



code	mm
855676	100x76x(L)270
855652	140x105x(L)308



**TURNER FLEXIBLE**



code	thickness (mm)	mm
855669	1,2	325x95
855737	1	360x73



**TURNER FLEXIBLE, PERFORATED**



code	thickness (mm)	mm
855720	1	370x73





### SPATULA

- For confectionery substances
- Smooth flexible blade

code	mm
855706	110x17
855690	203x34
855744	250x39



855744

855690

855706



### PALETTE KNIFE

- With flexible offset blade.

code	mm
855775	110x19
855782	320x32
855683	254x37



855683

855782

855775





659205



659304



659403



659014



659007



659106

**SCRAPER**

- ABS handle
- Blade made of synthetic rubber

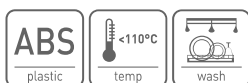

code	mm
659205	52x90x(L)257
659304	70x116x(L)358
659403	70x116x(L)410

**SCRAPER**

- ABS handle.
- Silicone blade.



code	mm
659014	55x90x(L)265
659007	70x105x(L)350
659106	70x105x(L)420

Spoon shaped blade



658604



658703



658802



658901



659458



659465



659472

**SCRAPER**

- Handle made of glass-fiber reinforced nylon.
- Blade made of natural rubber.
- Only suitable for cold food preparation.



code	mm
658604	55x90x(L)250
658703	55x90x(L)320
658802	55x90x(L)420
658901	100x150x(L)520

**SCRAPER SPOON SHAPED**

- ABS handle.
- Blade made of synthetic rubber.

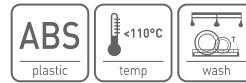

code	mm
659458	57x88x(L)254
659465	75x117x(L)357
659472	75x117x(L)408



### KITCHEN SPOON PBT

code	mm
563007	Ø70x380
563106	Ø80x450
563205	Ø105x600



563007



563106



563205



659700



659809



525005

### SPOON EXOGLASS

- Made of Exoglass material



code	mm
659700	300
659809	380

### WOODEN SPOON

- Made of wood.  
- Set of 3 different sizes



code	mm
525005	300-350-400



525142



658000

### SPATULA

- Wood



code	packed per	mm
525142	4	300

### SPATULA

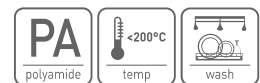

code	mm
658000	280



659601



659502

### SPATULA

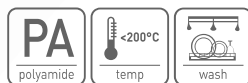

code	mm
659601	320

### SPATULA

- Slotted  
- Made of exoglass plastic



code	mm
659502	300



## LADLES & SKIMMERS PROFI LINE

- Professional, seamless one piece, in accordance with HACCP standards
- Heavy-duty stainless steel
- Thickness 2,7 mm



### LADLE NON-DRIP

- With non-drip pouring rim.

code	liter	Dimensions (mm)
540107	0,05	Ø60x300
540305	0,125	Ø80x320
540404	0,25	Ø100x400
540503	0,35	Ø120x450
540602	0,75	Ø145x440
540701	1	Ø165x480



Seamless, made out of one piece

Non-drip pouring rim



### SKIMMER

code	Dimensions (mm)
541104	Ø80x390
541203	Ø100x400
541302	Ø120x460
541500	Ø160x530





### BASTING SPOON

code	Dimensions (mm)
542606	100x65x430

### VEGETABLE SPOON

code	Dimensions (mm)
542507	100x65x480

### CARVING FORK

code	Dimensions (mm)
542705	35x350

### SPATULA

code	Dimensions (mm)
542200	100x110x510



### LADLES & SKIMMERS KITCHEN LINE

- Seamless, one piece
- In accordance with HACCP standard



### LADLE

code	liter	mm
527108	0,05	Ø60x300
527207	0,18	Ø90x360
527306	0,21	Ø100x380

### SKIMMER

code	mm
528105	Ø90x370
528204	Ø115x430

### SLOTTED SPATULA

code	mm
526118	340

### SPATULA

code	mm
526101	340

### CARVING FORK

code	mm
526200	35x350

### VEGETABLE SPOON

code	mm
526309	325





**WHISKS**



**FRENCH WHISK**

- 8 heavy stiff wires, with eyelet.
- Wire thickness: 2,2 mm.

code	mm
510001	250
510100	300
510209	350
510308	400
510407	450
511503	500
511602	550
511701	600



**FRENCH WHISK WITH PP HANDLE**

- 8 heavy stiff wires, with eyelet.
- Wire thickness: 2 mm.

code	mm
509012	230
509005	250
509104	300
509203	350
509302	400
509401	450



**DRESSING- AND PANWHISK**



code	mm
856109	160



532003

532102

532201

532300



Very flexible

Wire thickness:  
1,4 mm

### PIANO WHISK

- 7 flexible piano wires, with eyelet.
- Wire thickness: 1,4 mm.



code	mm
532003	200
532102	250
532201	300
532300	350



511718

511725

511732

511749

511756



Very flexible

Wire thickness:  
1,4 mm

### PIANO WHISK

- 12 flexible piano wires.
- Stainless steel handle with eyelet.



code	mm
511718	250
511725	300
511732	350
511749	400
511756	450



Very flexible

### PIANO WHISK

- 12 flexible piano wires.
- Polypropylene handle with eyelet.
- Wire thickness: 1,4 mm.



code	mm
509418	230
509425	250
509432	300
509449	350
509456	400
509463	450



509418

509425

509432

Wire thickness:  
1,4 mm

509449

511756





**BOWLS**



**KITCHEN BOWL**

code	liter	mm
530108	0,8	Ø160x(H)63
530207	1,3	Ø205x(H)70
530306	1,6	Ø225x(H)83
530405	2,3	Ø250x(H)84
530504	3,1	Ø280x(H)99
530603	5,0	Ø315x(H)108
530702	6	Ø345x(H)118

**MIXING BOWL - WITH ROUNDED BASE**

code	liter	mm
517109	0,7	Ø158x(H)55
517208	1,4	Ø197x(H)68
517307	2,3	Ø240x(H)88
517406	3,3	Ø259x(H)92
517604	4,9	Ø300x(H)118



647592

**VEGETABLE STRAINER**

- Fine wire mesh and wooden presser.
- With support and wire handle.



code	mm
647592	Ø200x390



Fitted with 2 scraping wires on the bottom



515501

**VEGETABLE STRAINER**

- Perfect for preparation of cream soups and tomato sauces.
- Including 2 straining discs (Ø140mm), coarse and fine.



code	mm
515501	Ø200x(H)110/195



## CONICAL STRAINER

mesh size  
0,5x0,5 mm



647509



647516

### CONICAL STRAINER, WIRE MESH

- Fine wire mesh with wire handle

18/10  
stainless steel

code	mm
647516	Ø160x355
647509	Ø180x395

mesh size  
0,5x0,5 mm



647561



647554

### CONICAL STRAINER, HALF WIRE MESH

- Fine wire mesh

18/10  
stainless steel

code	mm
647554	Ø205x460
647561	Ø245x475



547502

547502



547304

## CONICAL STRAINER

S.S.  
stainless steel

code	mm
547304	Ø185x350
547502	Ø235x395



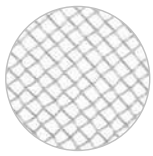

mesh size  
1x1 mm



635001

635209

635407

635605

**SIEVE**

- With wire handle



code	mm
635001	Ø120x280
635155	Ø160x320
635209	Ø180x340
635308	Ø200x360
635407	Ø230x400
635605	Ø250x435



mesh size  
4x4 mm/1,5x1,5 mm



639009

639016

639023

**SIEVE, DOUBLE MESH**

- Wooden handle

- Reinforcing bracket



code	mm
639009	Ø260x570
639016	Ø310x800
639023	Ø360x860



mesh size  
0,5x0,5 mm



638309

638507

638705

638903

**SIEVE - FINE MESH**

- With wire handle



code	mm
638309	Ø100x250
638507	Ø150x345
638705	Ø200x400
638903	Ø250x455

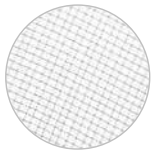

mesh size  
1x1 mm



637104

637302

637500

637609

**SIEVE**

- With wire handle



code	mm
637104	Ø160x305
637203	Ø180x325
637302	Ø200x360
637401	Ø220x380
637500	Ø240x410
637609	Ø260x440

## COLANDERS

### COLANDER PROFI LINE

- With base and 2 riveted handles



code	mm
535509	Ø320x(H)180
535516	Ø360x(H)200
535523	Ø400x(H)220



535523



535424

535417

535400



535301

535103

535202

### COLANDER PERFORATED

- With base and 2 handles.



code	mm	
535295	Ø160x(H)65	<b>NEW!</b>
535400	Ø235x(H)85	
535417	Ø285x(H)115	
535424	Ø315x(H)120	



535271

**NEW!**

### COLANDER SQUARE PERFORATED

- Square model, with base and 2 handles.



code	mm
535271	169x169x(H)55
535288	218x218x(H)70

### COLANDER KITCHEN LINE

- With base and 2 handles



code	mm
535103	Ø240x(H)110
535202	Ø280x(H)135
535301	Ø340x(H)160



535431

**NEW!**

### COLANDER PERFORATED

- With base and 2 handles.



code	mm
535431	Ø180x(H)90
535448	Ø220x(H)110
535455	Ø260x(H)140



**MEASURING JUG**



**MEASURING JUG  
POLYPROPYLENE**



code	liter	mm
567104	0,5	Ø90x(H)140
567203	1	Ø110x(H)170
567302	2	Ø140x(H)215
567401	3	Ø160x(H)240
567500	5	Ø190x(H)270

**NEW!**



**MEASURING JUG STACKABLE**



- Scale embossed in the side of the jug.
- Shape of the handle allows multiple jugs to be stacked.

code	liter	mm
567821	1	Ø125x(H)172
567838	2	Ø147x(H)215
567845	3	Ø172x(H)241
567852	5	Ø215x(H)271

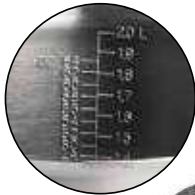

**MEASURING JUG STAINLESS STEEL**



- Heavy duty.

code	liter	mm
516102	0,5	Ø90x(H)110
516201	1	Ø120x(H)135
516300	2	Ø140x(H)175

**SCOOPS**



**SCOOP ALUMINIUM**



code	liter	length (mm)
521205	0,125	180
521304	0,2	205
521403	0,3	245
521502	0,5	265
521601	0,65	310
521809	2	390



**SCOOP POLYPROPYLENE**



code	liter	length (mm)
562000	0,125	187
562017	0,25	250
562079	0,65	330





580233



**KITCHEN SCALE 15 KG**

- Weighs up to 15.000g with gradation of  $\pm 1$ g with a minimum of 2g.
- Seamless stainless steel surface, housing made of HIPS plastic with integrated display.
- High precision strain gauge sensor for accurate measurements.
- Readout in grams.
- Touch control with on-off and tare buttons.
- With auto tare, overload and low power indication.
- Auto power off
- Powered by 3 AAA batteries (not included).

code	range	gradation	mm
580233	15 kg	1 g	266x269x(H)34



580226



**KITCHEN SCALE**

- Weighs up to 5000g with gradation of  $\pm 1$ g with a minimum of 20g.
- Seamless stainless steel surface with build in digital display.
- High precision strain gauge sensor for accurate measurements.
- Readout in g, kg, oz or lb'oz.
- Touch control with on-off/tare and unit buttons.
- With auto tare, overload and low power indication.
- Auto power off, powered by 2 CR2032 Lithium batteries, included.

code	range	gradation	mm
580226	5 kg	1 g	200x151x(H)11



580004



**DIGITAL SCALE**

- With integrated timer
- ABS housing with stainless steel tray
- Powered by 9V alkaline battery, not included

code	range	gradation	mm
580004	5 kg	1 g	170x215x(H)55



580301



**LARGE DIGITAL SCALE**

- Capacity max. 100kg (220lb)
- Graduation 50g (2oz)
- Readout in kg or lb
- Strain gauge technology for accurate measurement
- Stainless steel surface
- Operation through separate digital display with 4 buttons
- With power saving LCD display with battery indicator
- Powered by 2 AAA batteries, included

code	range	gradation	mm
580301	100 kg(220lb)	50 g(2oz)	300x255x(H)42



980033



**SCALE**

- Including  $\varnothing$  200 mm bowl

code	range	gradation	mm
980033	2 kg	10 g	210x140x(H)255



# Thermometers



	Infrared thermometer	Infrared pocket thermometer	Shock proof thermometer with probe	Fast response thermometer
Code	271148	271223	271407	271230
Unit	°C / °F	°C / °F	°C / °F	°C / °F
Reaction time	quick	quick	medium	quick
Temperature min.	-32°C	-55°C	-50°C	-50°C
Temperature max.	400°C	220°C	300°C	350°C
Accuracy	± 1,5°C	± 2°C	± 1°C	± 0,8°C
Gradation	0,1°C	0,1°C	0,1°C	0,1°C
Hold function	✓	✓	✓	✓
Probe length			213 mm	130 mm
Probe material			stainless steel	stainless steel
Suitable for use in the oven				
Waterproof			splash proof	✓
Auto off	✓	✓	✓	✓
Battery included	✓	✓	✓	✓
Additional information	Distance and spot size ratio 12:1 Laser pointer for accurate measurement target.	Distance and spot size ratio 1:1	Min / Max temperature function. With table stand, including protection case.	IP65 waterproof. With probe cover.





Thermometer with foldable probe	Pocket thermometer with probe	Waterproof thermometer	Roasting thermometer/timer
271308	271209	271162	271346
°C / °F	°C / °F	°C / °F	°C
medium	medium	medium	slowly
-50°C	-40°C	-50°C	0°C
300°C	200°C	300°C	300°C
± 1°C	± 1°C	± 1°C	± 1°C
0,1°C	0,1°C	0,1°C	1°C
✓	✓	✓	✓
110 mm	65 mm	120 mm	150 mm
stainless steel	stainless steel	stainless steel	stainless steel
			only probe
✓	✓	✓	✓
✓	✓	✓	✓
Min / Max temperature function.	With probe cover.	Measures temperature in one second. With cover and ergonomic handle.	With timer function. With temperature alert setting.



	Oven thermometer	Refrigerator thermometer	Pocket thermometer	Steak thermometer	Refrigerator thermometer	Refrigerator thermometer	Milk frothing thermometer
Code	271179	271186	271216	271339	271117	271124	271247
Unit	°C	°C	°C	°C	°C	°C	°C
Reaction time	slowly	slowly	medium	slowly	slowly	slowly	slowly
Temperature min.	50°C	-50°C	0°C		-40°C	-50°C	-10°C
Temperature max.	300°C	25°C	100°C		40°C	50°C	110°C
Gradation	10°C	10°C	1°C		1°C	1°C	1°C
Probe length			127 mm	50 mm			140 mm
Probe material			stainless steel	stainless steel			stainless steel
Suitable for use in the furnace	✓			✓			
Additional information	With special hook and support. Easy to read.	With special hook and support. Easy to read.	Probe cover with clip.	With indication rare-medium-well done.	Fitted with hook to hang from	Fitted with hook to hang from	With clip to fasten the thermometer to the milk jug





**NEW!  
MODEL!**



271308

**THERMOMETER WITH FOLDABLE PROBE**

- Temperature range from -50° to 300°C.
- Unit of measurement °C or °F.
- Gradation 0,1°C, accuracy 1°C between 0° and 100°C.
- Lock mode – for continuous monitoring of temperatures.
- Min/max temperature function.
- With foldable 110 mm long stainless steel probe.
- Turns off automatically after 60 minutes.
- Battery included.

code	range	mm
271308	-50/300°C	150



271148

**INFRARED THERMOMETER**

- Laser pointer for accurate target aiming.
- Measuring range -32°C to 400°C.
- Gradation 0,1°C, accuracy ±1,5°C/±1,5%.
- Distance spot ratio 12:1.
- Lock mode for continuous temperature monitoring.
- Turns off automatically.
- Battery included.



271223

**INFRARED POCKET THERMOMETER**

- Measuring range -55°C to 220°C.
- Unit of measurement °C or °F.
- Gradation 0,1°C, accuracy ±2%/2°C.
- Distance spot ratio 1:1, must be held close to the surface to be measured.
- Lock mode for continuous monitoring of temperatures.
- Min/max temperature function.
- Turns off automatically.
- Battery included.



271346

**ROASTING THERMOMETER/TIMER**

- With timer function.
- Temperature range from -50°C to 250°C.
- Unit of measurement °C or °F.
- Gradation 1°C.
- Lock mode – for continuous monitoring of temperatures.
- Min/max temperature function.
- Temperature alert setting.
- 150 mm stainless steel probe suitable for the oven (heat resistant).
- Battery included.

code	range	mm
271148	-32/400°C	37x70x(H)150

code	range	mm
271223	-55/220°C	22x39x(H)115

code	range	mm
271346	-50°C to 250°C	65x70x(H)117





271230

Provides fast and accurate temperature reading



### FAST RESPONSE THERMOMETER

- Provides fast and accurate temperature readings.
- IP65 waterproof.
- Measuring range -50°C to 350°C, unit of measurement °C or °F.
- Gradation 0,1°C, accuracy ±0,8%/0,8°C.
- Hold function - saves momentary temperature.
- 130 mm stainless steel probe.
- Turns off automatically.
- With probe cover.
- Battery included.



### POCKET THERMOMETER WITH PROBE

- Temperature range -40°C to 200°C.
- Unit of measurement °C or °F.
- Gradation 1°C.
- Accuracy ± 2°C.
- Hold function - saves momentary temperature.
- 65 mm stainless steel probe.
- Turns off automatically.
- With probe cover.
- Battery included.



271209



271162

### WATERPROOF THERMOMETER

- Waterproof.
- Temperature range -50°C to 300°C.
- Gradation 0,1°C between -19,9°C and 199,9°C, for other temperature ranges 1°C.
- Accuracy 1°C between -20°C and 100°C, for other temperature ranges ± 2°C.
- Lock mode - for continuous monitoring of temperatures.
- 120 mm stainless steel probe.
- Measures temperature in one second.
- With cover and ergonomic handle.
- Turns off automatically after 10 minutes.
- Battery included.

code	range	mm
271230	-50/350°C	204x42x(H)20

code	range	mm
271209	-40/200°C	20x150

code	range	mm
271162	-50/300°C	50x290



271407

### SHOCK PROOF THERMOMETER WITH PROBE

- Splash proof.
- Temperature range -50°C to 300°C.
- Unit of measurement °C or °F.
- Gradation 0,1, accuracy 1°C between -30°C and 150°C.
- Lock mode for continuous monitoring of temperatures.
- Min/max temperature function.
- 213 mm removable stainless steel probe.
- Turns off automatically.
- With table stand, including protection case.
- Battery included.

code	range	mm
271407	-50/300°C	85x195x(H)45



271216

### POCKET THERMOMETER

- Temperature range: from 0°C to 100°C.
- Gradation 1°C.
- 127 mm stainless steel probe.
- Probe cover with clip.
- Easy to read.

code	range	mm
271216	0/100°C	Ø44,5x140



271339

### STEAK THERMOMETER

- With indication rare-medium-well done.
- 50 mm stainless steel probe.
- Suitable for use in the oven.



code	packed per	mm
271339	4 on blistercard	Ø25





**S.S.**  
stainless steel



271179

**OVEN THERMOMETER**

- Temperature range from 50°C to 300°C.
- Gradation 10°C.
- Stainless steel housing with special hook and support.
- Easy to read.

code	range	mm
271179	50/300°C	Ø60x(H)70

**S.S.**  
stainless steel



271186

**REFRIGERATOR THERMOMETER**

- Temperature range from -50°C to +25°C.
- Gradation 2,5°C.
- Stainless steel housing with special hook and support.
- Easy to read.

code	range	mm
271186	-50/25°C	Ø60x(H)70



271124

**REFRIGERATOR THERMOMETER**

- With hook.
- Temperature range -50 °C to 50 °C.
- Gradation 1°C.
- Easy to read.

code	range	mm
271124	-50/50°C	Ø72x21



271247

**MILK FROTHING THERMOMETER**

- With clip to fasten the thermometer to the milk jug.
- Green marking indicates the ideal milk temperature for cappuccino etc.
- Temperature range -10 to 110°C.
- Gradation 1°C.
- Stainless steel probe with protective cover.
- Easy to read.

code	range	mm
271247	-10/110°C	Ø44x140



271117

**REFRIGERATOR THERMOMETER**

- With hook.
- Temperature range -40 to 40 °C.
- Gradation 1°C.

code	range	mm
271117	-40/40°C	23x150x(H)9



271155

With clip

Magnetic



**DIGITAL KITCHEN TIMER**

- With magnetic clip
- 99 min 59s count down
- Battery included

**ABS**  
plastic

code	mm
271155	67x(H)67



582022

With stand and magnet



**DIGITAL KITCHEN TIMER**

code	mm
582022	65x70x(H)17



582015

**ANALOG KITCHEN TIMER**

- Max. 60 minutes
- Accurate to 1 minute
- Magnetic rear
- Red marking indicates remaining time
- Well visible from a distance

code	mm
582015	Ø 80



551813



With three different nozzles (4, 5 and 6 mm)

### CONFECTIONERY FUNNEL KITCHEN LINE

- With ergonomic handle, design of stop valve ensures a tight seal.
- With three different nozzles (Ø 4, 5 and 6 mm).
- Designed for dosing sauces of various consistency and decorating of dishes and confectionery.
- With wire stand.

code	liter	mm
551813	1,5	270x195x270



551806



With three different nozzles (2, 4 and 6 mm)



### CONFECTIONERY FUNNEL PROFI LINE

- Ergonomic handle made of polypropylene.
- Design of stop valve ensures a tight seal.
- With three different nozzles (Ø 2, 4 and 6 mm).
- Wire stand and dripping dish.
- Designed for dosing sauces of various consistencies and decorating of dishes and confectionery.

code	liter	mm
551806	1,5	Ø190x(H)220





**DISPENSER BOTTLES**

- Bottle made of polyethylene, cap made of polypropylene.
- The cap helps the sauce stay fresh and maintains hygiene



**DISPENSER BOTTLES**

code	packed per	colour	liter	mm
558003	1	yellow	0,20	Ø50x185
558010	1	red	0,20	Ø50x185
558027	1	transparent	0,20	Ø50x185
557808	1	yellow	0,35	Ø55x205
557815	1	red	0,35	Ø55x205
557822	1	transparent	0,35	Ø55x205
557907	1	yellow	0,70	Ø70x240
557914	1	red	0,70	Ø70x240
557921	1	transparent	0,70	Ø70x240

**DISPENSER BOTTLE SETS**

code	packed per	colour	liter	mm
558034	3	yellow	0,20	Ø50x185
558041	3	red	0,20	Ø50x185
558058	3	transparent	0,20	Ø50x185
557839	3	yellow	0,35	Ø55x205
557846	3	red	0,35	Ø55x205
557853	3	transparent	0,35	Ø55x205
557938	3	yellow	0,70	Ø70x240
557945	3	red	0,70	Ø70x240
557952	3	transparent	0,70	Ø70x240



630648

**HOTDOG STAND**

- Quality finish.
- 2 dispenser bottle slots and 2 hotdog slots.
- Suitable for Hendi Dispenser bottles 70 cl.



code	mm
630648	260x110x(H)118



## DISPENSER BOTTLES

- Bottle made of polyethylene, cap made of polypropylene.
- The design of the bottle and the flexible material makes dispensing effortless.
- Cap closes securely and ensure freshness and hygiene.
- The small opening insures that sauce doesn't drip out when the bottle is held upside down.

Dispensing is very easy thanks to the flexible material



558324

558386

558447



558355

### DISPENSER BOTTLE EASY SQUEEZE

code	packed per	colour	liter	mm
558324	1	Transparent	0,20	Ø60x(H)170
558386	1	Transparent	0,30	Ø65x(H)190
558447	1	Transparent	0,60	Ø75x(H)240

### DISPENSER BOTTLE SETS EASY SQUEEZE

code	packed per	colour	liter	mm
558355	3	Transparent	0,20	Ø60x(H)170
558416	3	Transparent	0,30	Ø65x(H)190
558478	3	Transparent	0,60	Ø75x(H)240



557969

### SAUCE STAND

- Quality finish.
- With 3 holes.
- Suitable for Hendi dispenser bottles.

18/0  
stainless steel

code	mm
557969	209x80x(H)78
557976	229x90x(H)78
557983	274x102x(H)98





### FOOD RING ROUND

– Perfect for plating food in refined shapes.

code	mm
512135	Ø60x(H)45
512104	Ø70x(H)45
512302	Ø90x(H)45



### FOOD RING AND PUSHER ROUND

– Perfect for plating food in refined shapes.

code		mm
512142	food ring	Ø80x(H)45
512159	food ring	Ø100x(H)45
512203	pusher	Ø80
512210	pusher	Ø100



### FOOD RING AND PUSHER SQUARE

– Perfect for plating food in refined shapes.

code		mm
512166	food ring	65x65x(H)45
512173	food ring	80x80x(H)45
512227	pusher	65x65
512234	pusher	80x80





### SMOKE INFUSER

- The aluminium body functions as a heat sink, cooling the smoke before expelling it.
- Wood requires no pre-soaking prior to smoking.
- Can also be used with tea or spices.
- Removable smoking chamber with integrated filter.
- Flexible rubber hose (30 cm long) for easy injection of smoke into resealable bags and containers.
- Compact and lightweight enough to use with one hand.
- Gentle enough for use on delicate fruits and vegetables without changing their texture or temperature.
- Powered by 2 AA batteries, not included.
- Wood or herbs for smoking not included.

code	mm
199961	Ø68x(H)158

### GLASS DOME

- Ideal to use in combination with the smoke infuser, create a spectacular way to present dishes to customers.

code	mm
199978	Ø245x(H)150



### SMOKING GUN PRO - SAGE COMMERCIAL

- The smoking gun pro allows you to infuse a variety of foods and drinks with natural smoky flavours like applewood & hickory without adding any heat.
- Removable stainless steel combustion chamber and smoking barrel, can't be melted by blowtorch use and prevents resin build up.
- The 50 cm flexible rubber hose is easy to install and remove.
- Heavy-duty removable fan - will not melt when heated. Fan can be removed for cleaning with the supplied Allen key.
- Efficient, low-noise motor with air flow adjustment knob.
- Runs on 4 AA batteries (included).
- Includes two 1/2 OZ sample jars of PolyScience® Hickory and Apple Wood Smoking Sawdust.

code	mm
199985	150x80x(H)165

**NEW!**



199961

**NEW!**



199978

Reference wood chips page 160

**NEW!**



199985





Can safely be kept warm in the bain marie

CREAM WHIPPERS



588017



588024



see movie



589205

**CREAM WHIPPER PROFI LINE**

- Makes delicious whipped cream, mousses, desserts, cold foams and sauces easily
- Perfect for garnishing cappuccinos, coffees, shakes and ice cream
- Suitable for dispensing warm creams and sauces up to 70°C
- Keeps contents fresh for up to 14 days in the refrigerator
- Includes 3 stainless steel nozzles and a cleaning brush
- Requires cream charger (N<sub>2</sub>O) to operate, not included

code	liter	mm
588017	0,5	Ø85x(H)235
588024	1	Ø98x(H)330
589205	spare parts	





588147



**NEW!**

**THERMO CREAM WHIPPER**

- Bottle and head made of high quality stainless steel, designed for professional use.
- Versatile whipper for preparation of a wide range of hot and cold creams, foams, mousses, soups etc. etc.
- The whipper can be kept warm in hot water up to 70°C.
- Double-walled bottle insulates the contents, keeping it hot or cold for hours.
- Includes a set of 3 nozzles, of which 2 are stainless steel and 1 is polypropylene, and a cleaning brush.
- Requires cream charger (N<sub>2</sub>O) to operate, not included.

code	liter	mm
588147	0,5	Ø105x(H)278



**DECORATING AND INJECTOR TIPS**

- Ideal for decoration, filling, injections and marinating.
- Set of 4 stainless steel tips:
  - 1 long injector tip Ø3 mm
  - 1 long injector tip Ø5 mm
  - 1 short injector tip Ø3 mm
  - 1 short injector tip Ø5 mm
- Only suitable for use with Hendi Profi Line cream whippers.

code
589106



for cream



for liquid



for decorating



for decorating



**FUNNEL WITH SIEVE**

- Makes it easy to add ingredients to the cream whipper without clumps.
- Set of funnel and sieve.
- Funnel fits on the cream whippers perfectly.

code	mm
589113	Ø160x(H)90x(L)340



589113





588376

588031

588369



589007

**CREAM WHIPPER KITCHEN LINE**

- Aluminium head, white coated aluminium bottle and cream charger holder.
- Set of 3 polypropylene nozzle, as well as a cleaning brush.
- Not suitable for hot sauces.
- Requires cream charger (N<sub>2</sub>O) to operate, not included.

code	liter	mm
588031	0,25	Ø80x(H)200
588369	0,5	Ø80x(H)260
588376	0,95	Ø95x(H)320
589007		spare parts



**NEW!**



589007



**CREAM WHIPPER KITCHEN LINE BLACK**

- Matte black coated aluminium bottle, head and cream charger holder.
- Set of 3 polypropylene nozzle, as well as a cleaning brush.
- Not suitable for hot sauces.
- Requires cream charger (N<sub>2</sub>O) to operate, not included.

code	liter	mm
588420	0,5	Ø80x(H)260



588208



588215



586907



UNIVERSAL FOR ALL WHIPPED CREAM MAKERS

**CREAM WHIPPER CHARGERS**

- Universal for 'Liss', 'Kidde', 'Kaiser', 'ISI' etc.
- N<sub>2</sub>O
- Best before 5 years after production date.

code	order unit	packed per
588208	36	10
588215	25	24
586907	12	50







**stöckel**

BAKERY & PASTRY



755143

755037

755006

755075

**ICE CREAM SCOOP STÖCKEL**

code	liter	mm
755006	1/4	Ø 100
755013	1/8	Ø 80
755020	1/10	Ø 70
755037	1/12	Ø 67
755044	1/16	Ø 59
755051	1/20	Ø 56
755068	1/24	Ø 51
755075	1/30	Ø 49
755082	1/36	Ø 47
755099	1/40	Ø 45
755105	1/50	Ø 43
755112	1/60	Ø 40
755143	1/100	Ø 30



**stöckel**



755259

755273

**ICE CREAM SCOOP STÖCKEL - OVAL**

code	liter	mm
755259	1/20	70x52
755273	1/30	62x43





**stöckel**

755372

755334



**ICE CREAM SCOOP STÖCKEL**

- Fiberglass-reinforced nylon handle
- Easier identification of portion

code	liter	mm
755334	1/12	Ø 67
755341	1/16	Ø 59
755358	1/20	Ø 56
755365	1/24	Ø 51
755372	1/30	Ø 49
755389	1/36	Ø 47
755396	1/40	Ø 45



**stöckel**



**ICE CREAM DIPPER STÖCKEL**

code	liter	mm
755556	1/20	Ø 56x120
755563	1/24	Ø 51x120
755570	1/30	Ø 49x120

**ICE CREAM DIPPER STÖCKEL**

- With ceramic coating and extra long handle

code	liter	mm
755686	1/20	Ø 56x170
755693	1/30	Ø 49x170

**ICE CREAM DIPPER STÖCKEL**

- With extra long handle

code	liter	mm
755655	1/20	Ø 56x170
755679	1/30	Ø 49x170





759264

759233

759240

**ICE CREAM SCOOP PROFI LINE**

code	liter	mm
759233	1/24	Ø 53
759240	1/30	Ø 50
759257	1/36	Ø 48
759264	1/40	Ø 46



572719

572016

572313

**ICE CREAM SCOOP KITCHEN LINE**

code	liter	mm
572016	1/10	Ø 70
572115	1/12	Ø 66
572214	1/16	Ø 59
572313	1/20	Ø 56
572412	1/24	Ø 53
572511	1/30	Ø 50
572610	1/36	Ø 48
572719	1/40	Ø 44



## ICE CREAM SPATULAS WITH TRITAN GRIP

18/10  
stainless steel

code	colour	mm
755808	blue	260
755815	red	260
755822	yellow	260
755839	purple	260



755815



755822



755839



## ICE CREAM CONES STAND

- Fits 3 cones



code	mm
755730	200x95x(H)85



## ICE CREAM DIPPER KITCHEN LINE

- With extra long handle

- Filled with oil, ice-cream slides off more easily



code	liter	mm
759301	1/30	Ø49x225



759301







802052



**ICE CREAM CONTAINER PROFI LINE**

- The highest professional quality.
- 0.8 mm thick.
- Very solid design.
- Smooth edges, easy to clean.
- Can be used in freezers.

code	liter	mm
802021	6,5	360x165x(H)150
802038	5	360x165x(H)120
802045	3,6	360x165x(H)80
802052	5	360x250x(H)80



807019

**ICE CREAM CONTAINER KITCHEN LINE**

- Very solid design
- Smooth edges, easy to clean
- Can be used in freezers



code	liter	mm
807019	5	360x165x(H)120



807026



807071

807033

**NEW!**



**ICE CREAM CONTAINER POLYCARBONATE**

code	colour	mm
807026	transparent	360x165x(H)120
807033	black	360x165x(H)120
807057	transparent	360x250x(H)80
807071	black	360x250x(H)80

807095



**NEW!**

**ICE CREAM CONTAINER LID POLYCARBONATE**

- Suitable for polycarbonate ice cream containers.

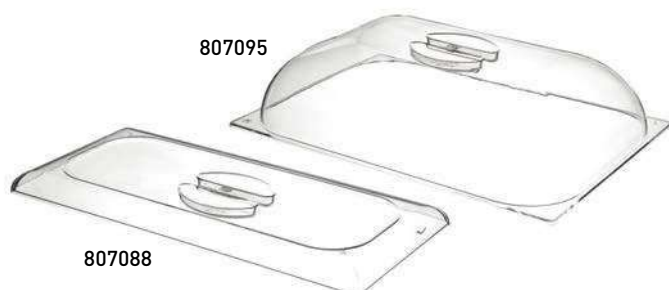

807088

code	mm
807088	360x165
807095	360x250





### ICE CREAM MAKER

- Ideal for making ice cream, sorbets and frozen yoghurt in up to 90 minutes.
- 2L ice cream container made of stainless steel.
- Air-cooled compressor with temperature range: -10°C to -35°C.
- With 2 hours cooling extension function to help keep the ice's consistency after it's ready.
- Prior chilling of ingredients not necessary.
- Large, back-lit digital display showing working time, freezing temperature and motion of the mixer.
- Easy to mount mixing paddle made of polypropylene.
- Transparent polycarbonate lid with "Twist-Lock" safe close system.
- Refrigerant: R600a.

code	V	W	mm
274231	230	180	272x315x(H)362



Easy to assemble and disassemble

Large 2 liter ice cream container

Easy to operate



Easy to operate



Large 2 liter ice cream container



Measuring cup and spoon included





550120

550328

550526



550106

550304

550502

**PASTRY BAG**

- Cotton, inside coated with polyurethane.
- With a tag.
- Suitable for cleaning in boiling water.

code	packed per	mm
550120	2	300
550229	2	350
550328	2	400
550427	2	450
550526	2	500

**PASTRY BAG**

- Made of seamless super nylon.
- Heavy duty, with a hang tag.
- Suitable for cleaning in boiling water.

**NEW!**

code	packed per	mm
550106	1	300
550205	1	350
550304	1	400
550403	1	450
550502	1	500



550113

**NEW!**



**WALL RACK FOR PASTRY BAGS**

- With 4 slots for hanging icing bags, 31 supports for storing icing tips, 7 hooks to hang tools like spatula's and a small rack for little accessories.

code
550113

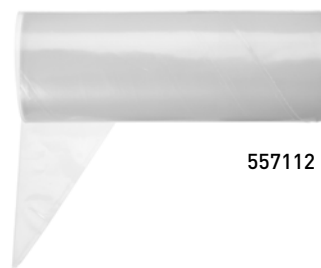

557112

**PASTRY BAG**

- Disposable.
- Suitable for hot and cold preparation.
- Meets hygienic HACCP standards.
- Material thickness 80 micron.
- Roll of 100 in box.



code		mm
557112	transparent	445x220
557105	transparent	530x285



557303

**PASTRY BAG ANTI SLIP**

- Biodegradable disposable bags.
- Suitable for hot and cold preparation.
- Meets hygienic HACCP standards.
- Material thickness 80 micron.
- Roll of 100 in box.



code		mm
557303	blue - anti slip	515x280

### ICING TIPS - SERRATED

- Set of 5 sizes.



code	mm
551790	Ø 6-8-10-12-14



551790

### ICING TIPS - SMOOTH

- Set of 5 sizes.



code	mm
551691	Ø 2-4-6-8-10



551691

### ICING TIPS SET FLOWER & PETAL

- Set consist of 5 icing tips for decorating:

- 2 closed Star tips
- 1 drop Flower tip
- 1 french Star tip
- 1 v-shaped tip

- Extra precise thanks to sharp edges.



code	
551202	



551202

### ICING TIPS SET FILLING & DECORATING

- Set consist of 5 icing tubes for:

- Filling
- Macarons
- Decorating
- Basket weave
- Writing

- Extra precise thanks to sharp edges



code	
551592	



551592

### ICING TIPS - SERRATED

- Set of 7 sizes.



code	mm
551110	Ø 3-5-7-9-11-13-15



551110

### ICING TIPS - SMOOTH

- Set of 7 sizes.



code	mm
551011	Ø 5-7-9-11-13-15-17

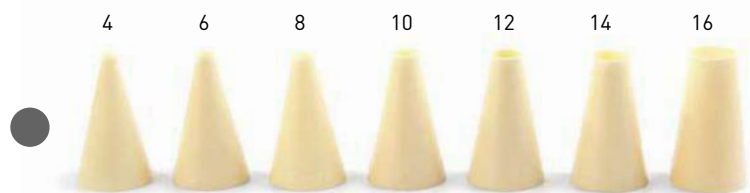

551011



551400

### ICING TIPS - ASSORTED

- Set of 12 different icing tubes in a storing box.



code	mm
551400	Ø 6-8-10-12



551417

### ICING TUBES - ASSORTED

- Set of 20 different icing tubes.  
- Made of blue polystyrene.  
- Comes with storage box.

code	
551417	





512227



512135



512104



512166



512173



512142



512159



512302

**FOOD RING AND PUSHER SQUARE**

- Perfect for plating food in refined shapes.

**FOOD RING AND PUSHER ROUND**

- Perfect for plating food in refined shapes.

**FOOD RING ROUND**

- Perfect for plating food in refined shapes.

code		mm
512166	food ring	65x65x(H)45
512173	food ring	80x80x(H)45
512227	pusher	65x65
512234	pusher	80x80

code		mm
512142	food ring	Ø80x(H)45
512159	food ring	Ø100x(H)45
512203	pusher	Ø80
512210	pusher	Ø100

code		mm
512135		Ø60x(H)45
512104		Ø70x(H)45
512302		Ø90x(H)45



689608



689806



518519



**BABA MOULD**



code		mm
689608	With rolled rim	Ø 70x(H)68
689806	with smooth rim	Ø 70x(H)68

**DARIOLE MOULDS**



code	packed per	mm
518519	3	Ø60x(H)45
518533	3	Ø85x(H)50



**CAKE MOULD**  
- Rectangular

code	mm
682104	180x80x(H)60
682302	260x100x(H)75
682401	300x110x(H)75



682104

682302

682401





**PASTRY CUTTER SET**  
- 14-piece set, round model



code		mm
673416	with plain edge, on card	Ø 19-112
674413	with serrated edge, on card	Ø 18-108



673416



674413

**NEW!**  
**BUTTER AND FAT BRUSH FLAT**

- With stainless steel bristles.  
- High temperature resistant.



code	mm
515389	25x200
515396	50x220



515389



515396



515228



515327

**BUTTER AND FAT BRUSH FLAT**  
- With wooden handle



code	packed per	mm
515228	2	20x210
515327	2	40x210



515358



515365

**BUTTER AND FAT BRUSH FLAT SILICONE**  
- With polypropylene handle

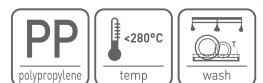

code	mm
515358	35x235
515365	50x235





**DOUGH CUTTER & SCRAPER**

554432



**DOUGH SCRAPER**  
- Trapezoidal



code	packed per	mm
554432	3	216x128

554364



**DOUGH SCRAPER**  
- Rectangular



code	packed per	mm
554364	6	120x96

554166



**DOUGH SCRAPER FLEXIBLE**  
- Semi-circular



code	packed per	mm
554166	6	120x88

**NEW!**



515044

**5 WHEEL DOUGH CUTTER**

- Cutting width can easily adjusted.  
- With 5 smooth Ø55 mm stainless steel cutting wheels.



code
515044

855751



**DOUGH CUTTER**

- Stainless steel with polypropylene handle



code	mm
855751	150x110

553404



**DOUGH CUTTER**

code	mm
553404	150x110



# NON-STICK BAKING MATS, GRIDS & PAPER



## BAKING MAT NON-STICK SILICONE

code	thickness (mm)	mm
677834	0,7	300x400
677810	0,7	530x325
677827	0,7	600x400

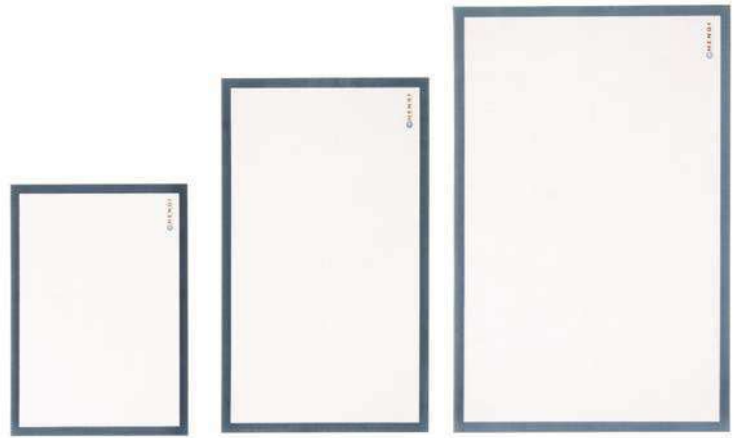

677834

677810

677827

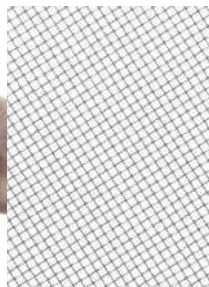

for powdered sugar

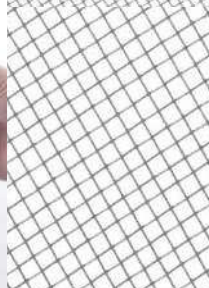

for flour and meal

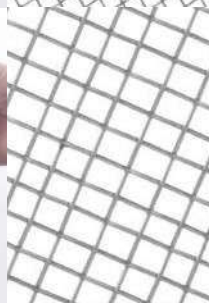

for bread-crumbs



637791

## BAKERS' SIEVE - With hanging loop.

code		mm int.	mm
637791	for powdered sugar	Ø247	Ø250x(H)75
637807	for flour and meal	Ø247	Ø250x(H)75
637814	for bread-crumbs	Ø247	Ø250x(H)75
637821	for powdered sugar	Ø407	Ø410x(H)80
637838	for flour and meal	Ø407	Ø410x(H)80
637845	for bread-crumbs	Ø407	Ø410x(H)80







## SILICONE BAKING MOULDS

- Made of 100% non-stick silicone coating

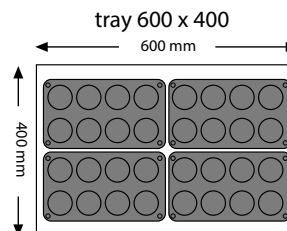
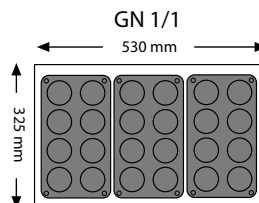
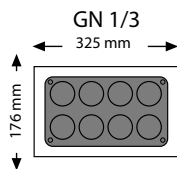

676202

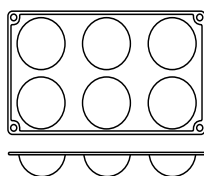

676509

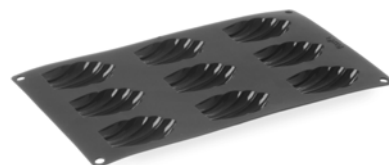
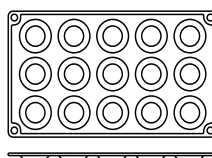

676707

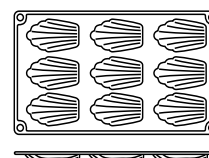

### SEMI-SPHERE

code	mm	per mould
676202	Ø 70x32(H)	6

### TARTELETTE

code	mm	per mould
676509	Ø 50x17(H)	15

### MADELEINES

code	mm	per mould
676707	70x47x17(H)	9

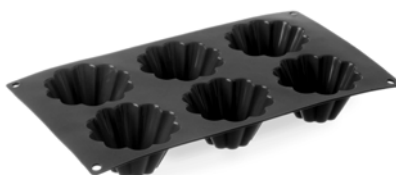

676806

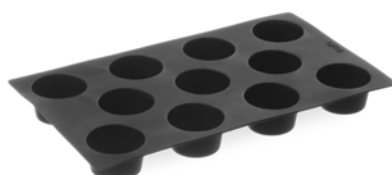
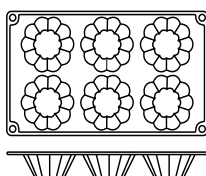

676905

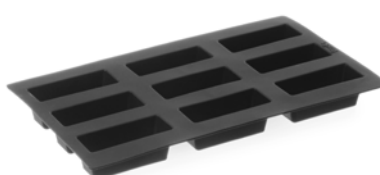
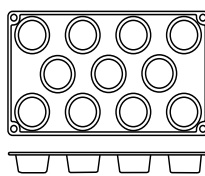

677001

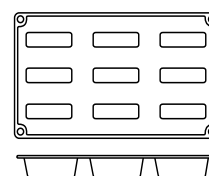

### BRIOCLETTE

code	mm	per mould
676806	Ø 80x40(H)	6

### MINI-MUFFINS

code	mm	per mould
676905	Ø 53x30(H)	11

### MINI-CAKE

code	mm	per mould
677001	80x30x33(H)	9



677209

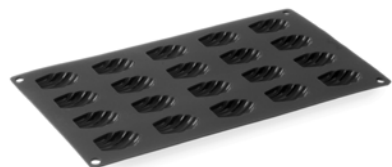
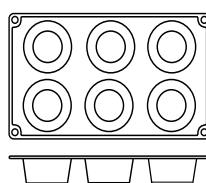

677308

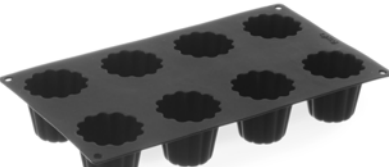
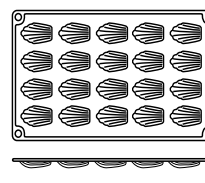

677506

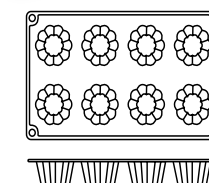

### MUFFINS

code	mm	per mould
677209	Ø 69x40(H)	6

### MINI-MADELEINES

code	mm	per mould
677308	42x29x11(H)	20

### CANNELE BORDELAIS

code	mm	per mould
677506	Ø 54x48(H)	8





515006

**ROLLING PIN**

- With slide bearings



code	weight (kg)	mm
515006	1,8	Ø 65x250/470



515013

**ROLLING PIN**

- Stainless steel with non-stick coating
- With slide bearings
- Including chrome-plated storage stand



code	weight (kg)	mm
515013	1,65	Ø 65x250/470



515020

**WOODEN ROLLING PIN**

- With ball bearings.



code	weight (kg)	mm
515020	1,6	Ø75x380/590



515037



**DOUGH DOCKER**

- 60 mm wide roller with 32 long durable plastic spikes to handle thick doughs.
- Can be used on both pastry and pizza dough.
- Use it to prevent undesired rising or blistering.

code
515037



**NEW!**





See movie

**CRÈME-BRÛLÉE BURNER ANTI FLARING**

- This Crème-Brûlée burner can be used in any angle, even upside down, without flaring.
- The burner is easily and securely attached to the gas cartridge, after emptying the cartridge simply attach the burner to a new cartridge.
- The flame is easy to ignite thanks to the piezo ignition and burns bright blue.

code		mm
198230	Set burner & cartridge	190x65x(H)250
198216	Burner only	190x35x65
199039	Order unit: box with 7 sets of 4 cartridges	Set of 4 cartridges



199039

Usable in every angle, even upside down without flaring



360°



Available as set or as separate items

It's simple to attach the burner to the canister

Suitable for multiple purposes





see movie



198209



198223



199046

### CRÈME-BRÛLÉE BURNER

- Gas, refillable - automatic ignition.
- Burner is supplied empty.
- Complete with base.

code	mm
198209	145x(H)190

### CRÈME-BRÛLÉE BURNER

- Gas, refillable - automatic ignition.
- Burner is supplied empty.
- Complete with base.

code	mm
198223	115x(H)155

### GAS CANISTER

- With various filling nozzles

code	packed per	ml
199046	4	200

### GAS LIGHTER

- Refillable
- Supplied empty

code	packed per	mm
198124	2	230



198124



783153

783160

783177

### RAMEKIN

- Ribbed

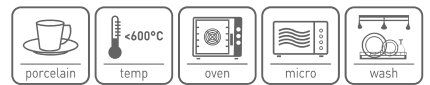

code	mm
783153	Ø70x(H)35
783160	Ø90x(H)48
783627	Ø100x(H)25
783177	Ø120x(H)55





**VEGETABLE CUTTER PROFI LINE**

- Suitable for cutting large quantities of vegetables.
- Contains 5 different discs for different cutting results: slices 2 and 4 mm and graters 3, 5 and 7 mm.
- Big inlet with lever for inserting big pieces.
- Small inlet with pusher for inserting smaller pieces.
- Cast aluminium housing.
- 2 security systems: first - screw locks the cover, second - electromagnetic sensor (opening the cover turns off the machine).
- Speed: 295 rpm.
- Weight: 24 kg

code	W	mm
231807	550	540x240x(H)450



231807



see movie

Big inlet for inserting big pieces of vegetables



Small inlet for inserting small pieces of vegetables



5 discs included, 2 for slicing 3 for grating



280096



**SLICING DISC**

- For vegetable cutter 231807 & 231852

code	thickness (mm)	type
280096	1	DF-1
280102	2	DF-2
280126	4	DF-4
280201	6	DF-6
280218	8	DF-8
280225	10	DF-10



280317



**GRATING DISC**

- For vegetable cutter 231807 & 231852

code	thickness (mm)	type
280294	2	DT-2
280300	3	DT-3
280416	4,5	DT-5
280317	7	DT-7



280621



**RASPINGS DISC**

- For vegetable cutter 231807 & 231852

code
280621



## VEGETABLE CUTTER HEAVY DUTY

- Designed for cutting large amounts of vegetables.
- Large inlet for large vegetables, up to Ø 165 mm.
- Small inlet for long vegetables, i.e. carrots, cucumbers up to Ø 55 mm.
- Cutting chamber housing made of cast aluminium, bottom part of the housing made of stainless steel.
- Convenient pressing handle.
- 750W = 1hp air-cooled high-performance motor.
- Low-voltage control buttons: STOP, START (24 V).
- 2 security systems: cutter switches off upon lifting of the pressing handle and upon lifting of the upper cover of the chamber.
- Upon lowering of the pressing handle the cutter starts automatically.
- Easy and fast replacement of cutting disks.
- 5 cutting discs included:
  - 2 mm slices (disc with 3 blades)
  - 4 mm slices (disc with 3 blades)
  - 3 mm grater
  - 5 mm grater
  - 7 mm grater
- Evacuation disc.
- 4 rubber anti-slip feet.
- Speed: 300 rpm.
- Weight: 25 kg.



see movie

code	W	mm
231852	750	500x250x(H)470



231852



5 discs included,  
2 for slicing  
3 for grating



234730



**NEW!**

### DICING DISC

- For vegetable cutter 231807 & 231852.
- Must be used in combination with a slicing disc.

code	thickness (mm)
234730	8x8
234747	10x10

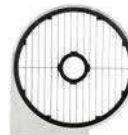

234754



**NEW!**

### FRENCH FRIES CUTTING DISC

- For vegetable cutter 231807 & 231852.
- Must be used in combination with a slicing disc.

code	thickness (mm)
234754	8
234761	10



280423



### JULIENNE DISC

- For vegetable cutter 231807 & 231852

code	thickness (mm)	type
280423	3x3	DQ-3



280690

### RACK FOR 18 VEGETABLE CUTTER DISCS

code	mm
280690	400x250x(H)90

**S.S.** **NEW!**  
stainless steel

FOOD PROCESSING



Transparent cover

226834

Peel trap

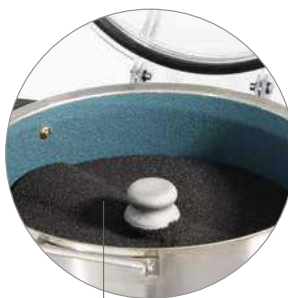

Abrasive disc



Digital timer

**POTATO PEELER PROFI LINE 5KG**

- Made entirely of stainless steel.
- Transparent cover.
- Digital timer.
- Peel trap directly below the appliance.
- Abrasive disc.
- Inside walls lined with removable abrasive material.
- Emergency stop switch.
- Conforms to CE requirements.
- Output 75 kg/h.
- Weight 35 kg.

code	V	W	mm
226834	5 kg	230	370 530x520x(H)700



630402

**FRENCH FRIES CUTTER**

- Knives made of stainless steel.
- Comes with 4 blades: 6, 9 and 13 mm, as well as a knife for 8 parts.
- Mountable to working table or wall.
- Handle covered by plastic for easier pressing.
- Stainless steel mounting plate allows easy removal and cleaning.
- With rubber feet to hold firmly when using on table.

code	mm
630402	430x168x(H)290
630419	Knife for 11 mm thick fries <b>NEW!</b>



**NEW!**

630419

**NEW!  
MODEL!**



222157

**STICK BLENDER**

- ABS plastic housing and a stainless steel shaft.
- Stainless steel cross shaped blade with titanium coating.
- Powerful 250W motor, 6 speeds with LCD display.
- Maximum speed 16000 rpm.
- Suitable for processing 1 to 4 liters.

code	V	W	mm
222157	230	250	71x71x(H)444



**STICK BLENDER 250VV**

**- WITH ADJUSTABLE SPEED**

- Professional version
- Housing made of fiber reinforced nylon
- Stainless steel shaft and blade
- Whisk attachment included (290 mm)
- Easy accessory changing clutch
- Easy to clean
- Ergonomic handle
- Shaft length: 250 mm
- Suitable for dishes up to 20 liters
- Speed control knob
- Speed: 2500 - 15000 RPM
- Weight 1,9 kg

code	V	W	mm
224373	230	250	Ø75x555

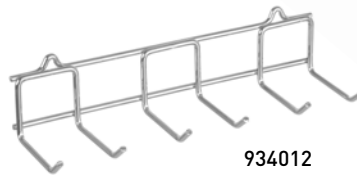

934012

**WALL MOUNTED STORAGE RACK FOR STICK BLENDER HENDI 250VV**

code
934012

**NEW!**



224373



**STICK BLENDERS KITCHEN LINE**

**STICK BLENDER KITCHEN LINE 160 WITH ADJUSTABLE SPEED**

- For professional use in ice-cream shops, restaurants, hotel kitchens for preparing ice cream mixes, vegetable soups, purees, sauces, stuffing, mayonnaise, tomato paste, pesto, etc.
- Ventilated motor.
- Housing with ergonomic handle made of durable plastic material.
- Stainless steel shaft and blade: length 160 mm, Ø 25 mm.
- Speed: Approx. 4,000 - 20,000 rpm
- Weight, including shaft: 1,61 kg.

code	kg	V	W	mm
222140	1,45	230	220	Ø75x464



222140

222164



180 mm

160 mm

**WHISK ATTACHMENT FOR STICK BLENDER 222140**

- Consists of two stainless steel whisks.
- Safe and easy attachment to the driving unit.

code	kg	mm
222164	0,4	185



**STICK BLENDERS PROFI LINE**

- Professional version.
- Housing made of fiber reinforced nylon.
- Stainless steel shaft and blade.
- Easy to clean.

**NEW!**

224328

**STICK BLENDER PROFI LINE 250  
- WITH FIXED SPEED**

- Shaft length: 250 mm.
- Suitable for dishes up to 20 liters.
- Weight 1,45 kg.
- Speed 15.000 RPM.



224335

**STICK BLENDER PROFI LINE 300  
- WITH ADJUSTABLE SPEED**

- Electronic control panel (9 speeds).
- Shaft length: 300 mm.
- Suitable for dishes up to 50 liters.
- Weight: 3,45 kg.
- Variable speed: 2000 - 9000 RPM.
- Maximum speed: 13.000 RPM.



224397

**STICK BLENDER PROFI LINE 400  
WITH ADJUSTABLE SPEED**

- Electronic control panel (9 speeds)
- Shaft length: 400 mm
- Suitable for dishes up to 80 liters
- Weight: 4,1 kg
- Variable speed: 2000 - 9000 RPM
- Maximum speed: 15.000 RPM

code	V	W	mm
224328	230	250	Ø75x285

code	V	W	mm
224335	230	300	Ø100x350

code	V	W	mm
224397	230	400	Ø100x350





224380

400

**STICK BLENDER PROFI LINE 400  
- ADJUSTABLE SPEED**

- With whisk attachment and wall mounted storage rack.
- Electronic control panel.
- 9 Speed settings between 2000 and 9000 rpm.
- Capacity up to 80 liter.
- Shaft length: 400 mm.
- Weight: 4,1 kg.

code	V	W	mm
224380	230	400	Ø100x350



224359

500

**STICK BLENDER PROFI LINE 500  
- WITH ADJUSTABLE SPEED**

- Electronic control panel (9 speeds).
- Shaft length: 500 mm.
- Suitable for dishes up to 100 liters.
- Weight: 4,1 kg.
- Variable speed: 2000 - 9000 RPM.
- Maximum speed: 15.000 RPM.

code	V	W	mm
224359	230	400	Ø100x350



**S.S.**  
stainless steel



224342

**WHISK ATTACHMENT FOR STICK BLENDER PROFI LINE 300 & 500**

- Consists of two whisks
- Easy and safe to attach.

code	mm
224342	Ø120x330



934029

224380

224342

**WALL MOUNTED STORAGE RACK**

code
934029



**PLANETARY MIXERS**



222829

**HEAVY DUTY MIXER 7 LITER**

- High quality cast steel body, injection-molded top cover and plastic bowl guard.
- High performance worm drive and gears.
- Safe to use because of multiple safety switches and overload protection.
- Stainless steel bowl, beater, whisk and dough hook are included.
- Easy to use digital control panel.
- Maximum flour mixing capacity: 1.8 kg.
- With handle to lift the bowl in place.
- Safety switch on the bowl guard, when the bowl guard is opened, the machine stops.
- 3 different speeds: 128/ 252/ 545 rpm.

code	liter	V	W	mm
222829	7	230	650	240x420x(H)425



222836

**HEAVY DUTY PLANETARY MIXER 10 LITER**

- High quality cast steel body, injection-molded top cover and chrome wire bowl cover.
- High performance worm drive and gears.
- Safe to use because of multiple safety switches and overload protection.
- Stainless steel bowl, beater, whisk and dough hook are included.
- Easy to use mechanical control panel.
- Maximum flour mixing capacity: 2.5 kg.
- With handle to lift the bowl in place.
- Lift and missing bowl safety switch.
- 3 different speeds: 148/ 244/ 480 rpm.

code	liter	V	W	mm
222836	10	230	600	450x470x(H)600



222843

**HEAVY DUTY PLANETARY MIXER 20 LITER**

- High quality cast steel body, injection-molded top cover and chrome wire bowl cover.
- High performance worm drive and gears.
- Safe to use because of multiple safety switches and overload protection.
- Stainless steel bowl, beater, whisk and dough hook are included.
- Easy to use mechanical control panel.
- Maximum flour mixing capacity: 5 kg.
- With handle to lift the bowl into place.
- Safety switches for height and presence of bowl.
- 3 different speeds: 197/ 317/ 462 rpm.

code	liter	V	W	mm
222843	20	230	1100	490x540x(H)780

## ELECTRIC MEAT TENDERIZER

- Perfect for restaurants, butcheries and catering establishments.
- Maximum meat piece size: 160 mm wide x 30 mm thick.
- Stainless steel housing.
- Rollers for beef and pork included.
- Tenderizer knife speed 75 RPM.
- Engine cooled with a built-in fan.
- 4 rubber feet.



Beef and pork tenderizer included



See movie



975305



975329

### ROLLERS FOR POULTRY

- Stainless steel case.
- 2 polypropylene pressing rollers.
- Roller length 180 mm.

code	mm
975329	235x130x(H)120



975312

### ROLLERS FOR SHOARMA

- Stainless steel case and knives
- 2 sets of knives cutting stripes 4 mm wide
- Roller length 165 mm

code	mm
975312	235x130x(H)120



## MEAT MINCERS



FOOD PROCESSING



### MEAT MINCER PROFI LINE 12

- High-quality professional device for grinding all kinds of skinless and boneless meat.
- Worm screw made of a special aluminium alloy.
- Body, hopper and meat container made of stainless steel.
- Polyethylene pusher included.
- Oil bathed gears (for smooth and extra quiet operation).
- Mincing disc diameter: 70 mm, holes: Ø 6 mm.
- Weight 19 kg.
- Not for continuous use.
- Output 200 kg/h.

code	V	W	mm
<b>282199</b>	230	750	370x220x(H)440

Worm screw made of aluminium alloy.

282199



282267

### PERFORATED PLATE

- Ø 70 mm

code	suitable for	mm
<b>282229</b>	282199	Ø 8
<b>282236</b>	282199	Ø 6
<b>282243</b>	282199	Ø 4,5
<b>282250</b>	282199	Ø 3
<b>282267</b>	282199	Ø 2



282359

### KNIFE

code	suitable for
<b>282359</b>	282199



282304

### WORM SCREW

- Made of anodized aluminium

code	suitable for
<b>282304</b>	282199





282007

### MEAT MINCER PROFI LINE 22

- High-quality professional device for grinding all kinds of skinless and boneless meat.
- Worm screw made of a special aluminium alloy.
- Body, hopper and meat container made of stainless steel.
- Polyethylene pusher included.
- Oil bathed gears (for smooth and extra quiet operation).
- Mincing disc diameter: 82 mm, holes: Ø 6 mm.
- Weight 24 kg.
- Not for continuous use.
- Output 300 kg/h.

code	V	W	mm
282007	230	1100	430x250x(H)510



282052

**PERFORATED PLATE**  
- Ø 82 mm

code	suitable for	mm
282014	282007	Ø8
282021	282007	Ø6
282038	282007	Ø4,5
282045	282007	Ø3
282052	282007	Ø2



**KNIFE**

code	suitable for
282076	282007



282076

**WORM SCREW**  
- Made of anodized aluminium

code	suitable for
282069	282007

282069





### MEAT MINCER KITCHEN LINE 12

- Stainless steel feeder tray, hopper made of a special aluminium alloy
- Knife and worm screw made of stainless steel and funnel of cast iron
- Stuffing tube and two Ø70mm mincing discs with Ø 6 and 8 mm holes included
- Easy disassembly for easy cleaning
- Motor with an overheat protection mechanism
- Anti-slip feet
- Output 100 kg/h
- Not for continuous use

code	V	W	mm
210802	230	550	432x261x(H)484



See movie



931233

#### PERFORATED PLATE

- Ø 70 mm

code	suitable for	mm
931233	210802	Ø8
931226	210802	Ø6
931219	210802	Ø4,5



931240

#### KNIFE



931257

#### WORM SCREW

code	suitable for
931257	210802



## MEAT MINCER KITCHEN LINE 22

- Stainless steel feeder tray, hopper made of a special aluminium alloy.
- Knife and worm screw made of stainless steel and funnel of cast iron.
- Stuffing tube and two Ø82 mm mincing discs with Ø 6 and 8 mm holes included.
- Easy disassembly for easy cleaning.
- Motor with an overheat protection mechanism.
- Anti-slip feet.
- Output 200-220 kg/h.
- Not for continuous use.

code	V	W	mm
210819	230	750	427x261x(H)486



210819



933343

### PERFORATED PLATE

- Ø 82 mm

code	suitable for	mm
933343	210819	Ø 8
933336	210819	Ø 6
933329	210819	Ø 4,5



933350

### KNIFE



933367

### WORM SCREW

code	suitable for
933367	210819





**MEAT MINCER 198**

- Ideal for small amounts and sausage making, not for commercial use.
- Aluminium housing.
- Die cast metal hopper with meat dish/dust cover.
- Pusher made of plastic.
- Aluminium worm screw and stainless steel knife.
- 2 mincing discs, diameter 65,8 mm included: 4 mm and 7 mm diameter holes.
- 3 sausage stuffing tubes: Ø 12, 15 and 20 mm.
- Steak tartare attachment.
- On/off/reverse switch.
- Not for continuous use.
- Weight 5,2 kg.

code	V	W	mm
210864	230	400	275x190x(H)347

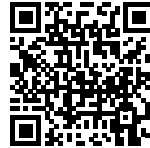

See movie

Meat dish with dust cover



Housing made of aluminium



210864



Three sausage stuffing tubes included

Worm screw made of aluminium, blade made of stainless steel



265109

**SAUSAGE CUTTER - ELECTRIC**

- Electric sausage cutter with double blade knife and adjustable thickness
- Extra long insertion tunnel for many types of sausages
- Maximum diameter of 48mm



code	V	W	mm
265109	230	135	230x185x(H)325





282113

### HAMBURGER PRESS

- Makes Ø130 mm hamburgers.
- Components in contact with meat are made of stainless steel.
- Bottom housing made of anodised aluminium.
- Handy lever for removing prepared hamburger patties from the press bowl.
- Container for patty dividers.

code		weight (kg)	mm
282113	hamburger diameter 130 mm	5,2	330x250x(H)300

**NEW!**



282120

### PATTY DIVIDERS

- Made of transparent cellulose.
- High temperature resistant and biodegradable.

code		weight (kg)	mm
282120	ca. 1400 pieces	1	Ø130



513033

### TORTILLA PRESS

- Makes max. Ø200 mm tortillas.
- Made of aluminium alloy with red powder coating on the exterior.

code	mm
513033	255x202x(H)95

513026

### HAMBURGER PRESS

- Makes Ø120 mm hamburgers.
- Made of aluminium alloy with non-stick coating.
- Handle made of polypropylene.

code	mm
513026	Ø120



SAUSAGE FILLING MACHINES

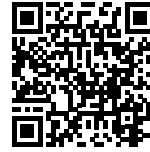

See movie



With a set of 4 stainless steel funnels



282151



282090



**SAUSAGE FILLING MACHINE  
PROFI LINE**

- Body, cylinder and a piston made of stainless steel.
- Equipped with a two-speed filling system that is easy to use.
- The piston can easily be removed for filling and cleaning.
- Equipped with bearings and gear train made of hardened steel, resistant to pressure.
- With set of four stainless steel funnels, diameter: 16/22/32/38 mm.

code	liter	mm	
282571	3	300x340x(H)570	<b>NEW!</b>
282588	5	300x340x(H)690	<b>NEW!</b>
282090	7	300x340x(H)830	
282151	10	370x320x(H)670	



With a set of 4 plastic funnels



282137



282144



**SAUSAGE FILLING MACHINE  
KITCHEN LINE**

- Body made of painted steel, cylinder and piston made of stainless steel.
- Equipped with a two-speed filling system that is easy to use.
- The piston can easily be removed for filling and cleaning.
- Equipped with bearings and gear train made of hardened steel, resistant to pressure.
- With set of four polypropylene funnels, diameter: 10/20/30/40 mm.

code	liter	mm	
282137	3	300x340x(H)570	
282144	5	300x340x(H)690	



**SLICER PROFI LINE 220 RED EDITION**

- Blade diameter: 220 mm.
- Steplessly adjustable cutting thickness up to 12 mm.
- Maximum slicing diameter: 150 mm.
- Finished with a special red coating.

code	V	W	mm
970294	230	280	440x420x(H)350



Slicing thickness is easy to adjust



Carriage with locking mechanism



Acrylic safety shield



Built-in sharpener



Heavy product holder







**MEAT SLICERS PROFI LINE**



- Intended for professional commercial use.
  - Housing made of coated aluminium, with non-slip feet.
  - Tilted blade made of hardened stainless steel.
  - Air-cooled motor with protection against overheating.
  - Motor with extra power for cutting hard meats.
  - Fitted with blade guard and built-in sharpener.
  - Carriage with safety shield and remnant holder with upright lock.
  - Quick and easy to disassemble for cleaning.
- Meets all safety requirements for commercial use, such as:
    - Setting 0 thickness keeps the blade behind the blade guard.
    - Protection against activation while the sharpener or the axle cover is removed.
    - Carriage can only be locked and removed while the blade is set to 0 thickness.
  - Not suitable for cutting cheese, only possible with separately sold non-stick coated knife.



210031



210048

**SLICER PROFI LINE 195**

- Blade diameter: 195 mm.
- Steplessly adjustable slicing thickness up to 12 mm.
- Maximum slicing diameter: 120 mm.

code	V	W	mm
210031	230	200	400x400x(H)330

**SLICER PROFI LINE 220**

- Blade diameter: 220 mm.
- Steplessly adjustable cutting thickness up to 15 mm.
- Maximum slicing diameter: 150 mm.

code	V	W	mm
210048	230	280	440x420x(H)350



Acrylic safety shield



Carriage with locking mechanism



Built-in sharpener



Blade protection



Sealed safety on/off switch



Air cooled engine protected by metal cover





see movie



210000



210017

### SLICER PROFI LINE 250

- Blade diameter: 250 mm.
- Steplessly adjustable cutting thickness up to 15 mm.
- Maximum slicing diameter: 180 mm.

code	V	W	mm
210000	230	320	485x420x(H)395

### SLICER PROFI LINE 300

- Blade diameter: 300 mm.
- Steplessly adjustable cutting thickness up to 15 mm.
- Maximum slicing diameter: 200 mm.

code	V	W	mm
210017	230	420	600x480x(H)450

### NON-STICK COATED BLADE

- For slicing cheese.

code	suitable for	mm
975800	210031	Ø195
975732	210048	Ø220
975749	210000	Ø250
975756	210017	Ø300



975732





210215

**SLICER KITCHEN LINE 250**

- Anodised aluminium housing.
- 0,2 hp air-cooled motor, protected by a plastic cover.
- Transparent safety screen during operation.
- Easily removable parts for fast cleaning.
- Safe blade protection and built-in blade sharpener.
- Tilted model with high-quality blade.
- Blade diameter: 250 mm.
- Estimated maximum diameter of the cut product: 180 mm.
- Steplessly adjustable cutting thickness up to 11 mm.
- Blade secured against rotation during housing removal.
- 4 anti-slip plastic feet.
- Weight: 16,4 kg.

code	V	W	mm
210215	230	150	494x402x(H)398



210246

**SLICER KITCHEN LINE 300**

- Anodised aluminium housing.
- 0,3 hp air-cooled motor, protected by a plastic cover.
- Transparent safety screen during operation.
- Easily removable parts for fast cleaning.
- Safe blade protection and built-in blade sharpener.
- Tilted model with high-quality blade.
- Blade diameter: 300 mm.
- Estimated maximum diameter of the cut product: 210 mm.
- Steplessly adjustable cutting thickness up to 14 mm.
- Blade secured against rotation during housing removal.
- 4 anti-slip plastic feet.
- Weight: 24 kg.

code	V	W	mm
210246	230	250	615x494x(H)477



See movie



210222

Acrylic safety shield

Built-in sharpener

**SLICER KITCHEN LINE 250 TEFLON COATED**

- Anodised aluminium housing.
- Blade, blade protection and product plate are coated with Teflon for easy cheese cutting.
- 0,2 hp air-cooled motor, secured from below with a plastic cover.
- Transparent safety screen during operation.
- Removable tray for easy cleaning of food leftovers following cutting.
- Blade protection easily removable for cleaning.
- Safe blade protection and built-in blade sharpener.
- Tilted model with high-quality blade.
- Blade diameter: 250 mm.
- Estimated maximum diameter of the cut product: 180 mm.
- Stepless adjustment of cutting thickness, from 0 to 11 mm.
- Blade secured against rotation during maintenance.
- 4 anti-slip plastic feet.
- Weight: 16,4 kg.

code	V	W	mm
210222	230	150	494x402x(H)398



**NEW!**



975398

**VACUUM CHAMBER PACKAGING MACHINE KITCHEN LINE**

- 295 mm long sealstrip, 3,5 mm wide.
- Body and chamber made of high quality stainless steel.
- Transparent ABS cover to control the packing process.
- For professional use.
- Regulated vacuum and sealing cycle time.
- Digital display of vacuum level.
- Pump capacity: 77 L/min.
- Chamber dimensions: 350x300x(H)110 mm.
- Weight: 24.4 kg.

code	sealing strip (mm)	V	W	mm
975398	295	230	630	429x359x(H)345



975251

**VACUUM CHAMBER PACKAGING MACHINE PROFI LINE**

- Designed for packing food and technical products.
- Body and chamber made of 304 high-quality stainless steel.
- Large recess in the bottom (exclusively in model no. 975251) and domed cover allow for packing large portions.
- High quality durable transparent cover enables visual control of the packing process.
- V-shaped gasket to guarantee high sealability.
- Digital display.
- User-friendly.
- Automatic operation.
- Adjustable sealing time.
- Pressure indicator.
- Pump capacity: 167 L/min., 975275: 333 L/min.

code	sealing strip (mm)	V	W	mm
975251	260	230	370	330x480x(H)360
975275	350	230	750	425x560x(H)460
975268	300	230	370	370x480x(H)435

**VACUUM COOKING BAGS**

- Suitable for sous vide cooking.
- 2-ply, inside layer 60 µm food contact approved Polyethylene, outside layer 15µm Polyamide (Nylon). Total thickness is 75 µm.
- The used materials act as an UV filter.
- Bags can be used in temperatures from -20° up to 110°C.
- Suitable for chamber vacuum packing machines.

code		mm
970676	100 pieces	150x200
970652	100 pieces	150x250
970683	100 pieces	200x300
970669	100 pieces	250x350
970690	100 pieces	300x400
971314	50 pieces	350x450
971321	50 pieces	400x400
971338	50 pieces	380x500

**NEW!**  
**NEW!**  
**NEW!**



# NEW!



201428

### VACUUM CHAMBER PACKAGING MACHINE PROFI LINE 260

- 260 mm seal strip, sealing bar width: 5 mm.
- Adjustable cycle and sealing time, automatic and manual operation.
- Suitable for vacuum packing liquid and wet food.
- Fitted with a digital display and a manual pressure gauge.
- High quality oil pump which provides high pressures (1009mbar) and fast vacuum speed.
- Body and chamber made of high quality stainless steel.
- Large recess in the bottom and domed transparent cover allow for packing large portions.
- Oil cooled pump capacity: 133,3 L/min.
- Chamber dimensions: 280x393x(H)110 mm

code	V	W	mm
201428	230	1000	330x480x(H)356



201435

### VACUUM CHAMBER PACKAGING MACHINE PROFI LINE 300

- 300 mm seal strip, sealing bar width: 5 mm.
- Adjustable cycle and sealing time, automatic and manual operation.
- Suitable for vacuum packing liquid and wet food.
- With marinate function.
- Fitted with a digital display and a manual pressure gauge.
- High quality oil pump which provides high pressures (1009mbar) and fast vacuum speed.
- Body and chamber made of high quality stainless steel.
- Large recess in the bottom and domed transparent cover allow for packing large portions.
- Pump capacity: 133,3 L/min.
- Chamber dimensions: 300x350x(H)110 mm

code	V	W	mm
201435	230	1100	359x425x(H)356

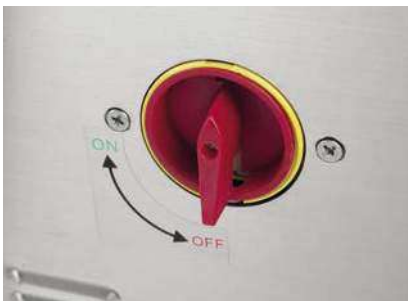

### VACUUM PACKING BAGS

- 2-ply, inside layer made from food contact approved Polyethylene, outside layer made from Polyamide (Nylon). Total thickness is 65 µm.
- Suitable for chamber vacuum packing machines.

code		mm
970607	100 pieces	140x200
970386	100 pieces	160x230
970614	100 pieces	200x300
970393	100 pieces	250x350
970621	100 pieces	300x400





### VACUUM CHAMBER PACKAGING MACHINE PROFI LINE 410

- 410 mm seal strip, sealing bar width: 3 mm.
- Adjustable vacuum, sealing, inflating and cooling time, automatic and manual operation.
- Suitable for vacuum packing liquid and wet food.
- Fitted with a digital display and a manual pressure gauge.
- High quality oil pump which provides high pressures (1009mbar) and fast vacuum speed.
- Body and chamber made of high quality stainless steel.
- Large recess in the bottom and domed transparent cover allow for packing large portions.
- With bag clamp inside the chamber to keep bags in place during operation.
- Pump capacity: 333,3 L/min.
- Chamber dimensions: 425x457x(H)100 mm

code	V	W	mm
201442	230	1300	495x567x(H)472

201442



See movie



**S.S.**  
 STAINLESS STEEL

975374

**VACUUM PACKAGING MACHINE KITCHEN LINE**

- 420 mm seal strip, sealing bar width: 5 mm.
- Suitable for bags on roll in combination with bag rolls attachment 970638.
- Digital display of vacuum and sealing cycle.
- Vacuum may be generated in a continuous or pulsating mode.
- Additional buttons for quick start of vacuum and sealing on the handle.
- Automatic switch-off after 10 minutes of idleness – energy saving.
- High power of the sealing bar reduces the sealing time to 2-3 s.
- High capacity double pump: 16l/min.
- Stainless steel body.
- Robust handle.
- Only suitable for embossed vacuum bags, up to 406mm width.
- Weight: 6.9 kg.

code	V	W	mm
975374	230	650	490x260x(H)145

 Roll attachment  
 can easily be  
 installed

**BAG ROLLS ATTACHMENT FOR 975374  
 VACUUM PACKAGING MACHINE  
 KITCHEN LINE**
**ABS**  
 plastic

- Can be attached to vacuum packaging machine Kitchen Line 975374 or as a stand-alone attachment for other vacuum packaging machines.
- Equipped with a removable knife to cut exactly the needed bag length.
- Internal dimensions: 412x101x(H)101 mm.
- For rolls with maximum dimensions of Ø100x400 mm.
- Base made of ABS.
- Transparent polycarbonate cover for easy control of the roll.

code	mm
970638	487x122x(H)107



970638

**EMBOSSED VACUUM BAGS ON ROLL**

- 2-ply, inside layer 60 µm food contact approved Polyethylene, outside layer 15µm Polyamide (Nylon). Total thickness is 75 µm.
- The used materials act as an UV filter.
- Embossing improves the air flow out of the bag during the vacuum packing process.
- Bags can be used in temperatures from -20° up to 100°C.
- Suitable for chamber and external vacuum packing machines.

code		mm
971062	set of 2 rolls	200x6000
971079	set of 2 rolls	280x6000



970362



### VACUUM PACKAGING MACHINE PROFI LINE

- Made of stainless steel.
- Professional vacuum pump and pressure gauge.
- Manual or automatic operation.
- Digital display.
- Adjustable sealing time.
- Teflon-coated sealing strip.
- Pump capacity: 20 L/min.
- For use with embossed bags only.

code	sealing strip (mm)	V	W	mm
970362	350	230	250	370x280x(H)170



### EMBOSSED VACUUM BAGS

- 2-ply, inside layer 60 µm food contact approved Polyethylene, outside layer 15µm Polyamide (Nylon). Total thickness is 75 µm.
- The used materials act as an UV filter.
- Embossing improves the air flow out of the bag during the vacuum packing process.
- Bags can be used in temperatures from -20° up to 100°C.
- Suitable for chamber and external vacuum packing machines.

code		mm
971017	100 pieces	150x250
971048	100 pieces	150x400
971024	100 pieces	200x300
971055	100 pieces	250x350
971031	100 pieces	300x400
971000	50 pieces	400x500

NEW!



# HOKKERS



THERMAL PROCESSING



147108



147801

## HOKKER BIG FLAME

- Model 'Big Flame' - for propane gas.
- Including converter set also suitable for natural gas.
- Very robust stainless steel frame to carry heavy loads.
- Fitted with thermocouple and electronic ignition.
- Fitted with enamelled pan support.
- Gas hose and pressure regulator included.
- Can be expanded with hokker base (147306), wok ring (147207) and wok (626504).

code	kW	mm
147108	6,7	425x425x(H)400

## HOKKER KITCHEN LINE

- Model Kitchen Line - for propane gas.
- Including converter set also suitable for natural gas.
- Fully stainless steel frame.
- Fitted with thermocouple and electronic ignition.
- Fitted with enamelled pan support.
- Gas hose and pressure regulator included.

code	kW	mm
147801	6,0	425x425x(H)400



147306

626504

## WOK

- With handles, sheet steel 1.5 mm thick
- Especially suitable for use in combination with stainless steel ring 147207 and Hokker 147108. Also suitable for stainless steel wok holder 149546 in combination with Green Fire barbecues



code	mm
626504	Ø700x(H)235

## RING FOR HOKKER

- To adapt Hokker 147108 to use with wok 626504



code	mm
147207	Ø 360x(H)80

## HOKKER BASE

- Suitable for hokkers: 147108



code	mm
147306	425x425x(H)400



## GAS COOKERS



### GAS COOKER - 5 BURNERS WITH ELECTRIC OVEN

- Suitable for natural gas.
- Conversion set for propane gas included.
- 3 burners of 3.0 kW.
- 1 small burner of 1.8 kW.
- 1 wok burner of 3.5 kW.
- Piezo ignition and thermocouple.
- Three-part cast iron pan support.
- Convection oven 1/1 GN with a capacity of 2.7 kW fitted with two ventilators, thermostat to 275°C and timer.
- Additional upper element of 2.5 kW for grilling.
- Stainless steel oven interior and inner door.
- Height-adjustable feet.
- Weight: 78 kg.

code	V	Power kW [Hz]	mm
225707	230	14.3	900x655x(H)850/900



225707

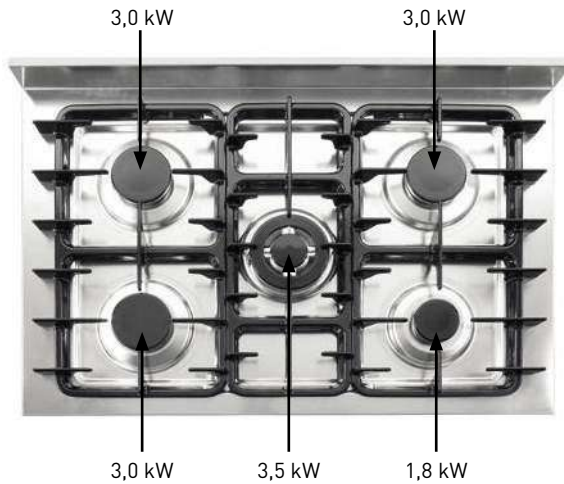

### GAS COOKER - 5 BURNERS, OPEN STAND

- Suitable for natural gas.
- Converter set for propane gas included.
- 3 burners of 3.0 kW.
- 1 small burner of 1.8 kW.
- 1 wok burner of 3.5 kW.
- With electronic ignition and thermocouples.
- Three-part cast iron pan support.
- Weight: 45 kg.

code	V	Power kW [Hz]	mm
225806	230	14.3	900x600x(H)850



225806



# NEW!

S.S.  
stainless steel

THERMAL PROCESSING



225882



### GAS COOKER KITCHEN LINE 4-BURNER WITH CONVECTION ELECTRIC OVEN GN 1/1

- Burners: 2 x 3.5 kW + 2 x 6 kW
- Pots: Ø120-300 mm
- Cast iron pan support 335x300mm, one for each burner
- Thermocouple
- Cooker top: AISI 304
- Casing: AISI 430
- Adjustable steel feet
- Weight: 82 kg
- CONVECTION OVEN GN 1/1:
  - Electric 3 kW/230 V
  - Stainless steel chamber: 640x370x(H)350 mm
  - 4 rail pairs for GN 1/1
  - Distance between rails: 75 mm
  - 1 GN1/1 grid included
  - Thermostat

code	V	kW	Power kW [Hs]	mm
225882	230	3	19	800x700x(H)900



225899

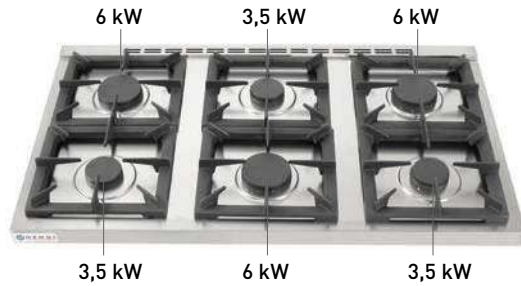

### GAS COOKER KITCHEN LINE 6-BURNER WITH CONVECTION ELECTRIC OVEN GN 1/1

- Burners: 3 x 3.5 kW + 3 x 6 kW
- Pots: Ø120-300 mm
- Cast iron pan support 335x300mm, one for each burner
- Thermocouple
- Cooker top: AISI 304
- Casing: AISI 430
- Adjustable steel feet
- Weight: 105 kg
- CONVECTION OVEN GN 1/1:
  - Electric 3 kW/230 V
  - Stainless steel chamber: 640x370x(H)350 mm
  - 4 rail pairs for GN 1/1
  - Distance between rails: 75 mm
  - 1 GN1/1 grid included
  - Thermostat

code	V	kW	Power kW [Hs]	mm
225899	230	3	28,5	1200x700x(H)900



226094

### GAS COOKER KITCHEN LINE 6-BURNER OPEN STAND

- Burners: 3x 3.5kW + 3x 6kW
- Pans: Ø120-300mm
- Cast iron pan support 335x300mm, one for each burner
- Cabinet closed on 4 sides, internal dimensions: 1198x570x(H)470 mm
- Thermocouple
- Cooker worktop: AISI 304
- Housing: AISI 430
- Steel adjustable feet: 100-165mm
- Weight: 95kg

code	Power kW [Hs]	mm
226094	28,5	1200x700x(H)900

# NEW!

S.S.  
stainless steel



227381

### GAS COOKER KITCHEN LINE 4-BURNER, TABLE TOP

- Burners: 2x 6 kW + 2x 3.5 kW
- Suitable pots and pans: Ø120-300 mm
- Thermocouple.
- AISI 304 cooker top.
- Side and back housing: AISI 430.
- Cast iron grates 335x300 mm, one for each burner
- Cast iron burners.
- GZ50 gas
- Extra LPG nozzles included.
- No igniters or pilot flame – match-lit flame.
- Steel feet with non-slip surface, with adjustment from 55 to 65 mm.
- Weight: 35 kg.

code	Power kW [Hs]	mm
227381	19	800x700x(H)310



227398

### GAS COOKER KITCHEN LINE 6-BURNER, TABLE TOP

- Burners: 3x 6 kW + 3x 3.5 kW.
- Suitable pots and pans: Ø120-300 mm.
- Thermocouple.
- AISI 304 cooker top
- Side and back housing: AISI 430.
- Cast iron grates 335x300 mm, one for each burner.
- Cast iron burners.
- GZ50 gas.
- Extra LPG nozzles included.
- No igniters or pilot flame – match-lit flame.
- Steel feet with non-slip surface, with adjustment from 55 to 65 mm
- Weight: 45 kg.

code	Power kW [Hs]	mm
227398	28,5	1200x700x(H)310

### PORTABLE GAS STOVE

- Safe to use through improved air cooling, thermal fuse prevents gas from flowing after the flame has gone out.
- Uses a gas can (butane) that's easy to install and replace.
- The clever design of the gas burner makes the burner wind-protected and therefore the stove can be used indoors and outdoors.
- Compact size and lightweight, comes with a 390x310x(H)130 mm case.
- Suitable for pans with a base diameter of up to 26 cm and a maximum content of 3 liter.

code	kW	mm
147610	2,2	373x290x(H)123



147610



### BUTANE GAS CARTRIDGE

- Only suitable for use in combination with portable gas stove (147610) and crème-brûlée burner anti flaring (198216).
- Not suitable for refilling gas lighters etc.
- Packed per 4 canisters.
- Order unit: box with 7 sets of 4 cans.

code	g
199039	227



199039





## INDUCTION COOKERS DISPLAY LINE



- Very clean design suitable for live cooking.
- Very flat housing with stainless steel frame.
- Surface of ceramic glass with integrated digital display.

THERMAL PROCESSING



239278

239285

239292

209523

Sturdy stainless steel frame

High quality ventilation

Touch-sensitive controls





### INDUCTION COOKER 2000W DISPLAY LINE

- Touch-sensitive controls, power or temperature adjustable in 10 steps.
- Temperature range: 35-240°C.
- Suitable for pans with bottom diameter between 120 and 230 mm.
- With timer function for 0-180 minutes.
- Equipped with electronic protection against overheating.

code	V	W	mm
239278	230	2000	293x373x(H)56



239278

	min Ø120 mm	2000 W
	max Ø230 mm	230 V



See movie

### DOUBLE INDUCTION COOKER DISPLAY LINE

- Touch-sensitive controls, power or temperature adjustable in 10 steps.
- With boost mode which temporarily shifts some power from right hob to the left hob, providing up to 2000W.
- The left side hob can output 1800W, or 2000W while the boost function is active.
- The right side hob can output 1700W, or 1500W while the boost function is active.
- Temperature range: 60-240°C.
- Suitable for pans with bottom diameter between 120 and 230 mm.
- With timer function for 0-180 minutes.
- Equipped with electronic protection against overheating.

code	V	W	mm
239285	230	3500	608x370x(H)61



239285

	min Ø120 mm	3500 W
	max Ø230 mm	230 V

### INDUCTION COOKER 3500W DISPLAY LINE

- Touch-sensitive controls, power or temperature adjustable in 10 steps.
- Temperature range: 35-240°C.
- Suitable for pans with bottom diameter between 140 and 280 mm.
- With timer function for 0-180 minutes.
- Equipped with electronic protection against overheating and air filter.

code	V	W	mm
239292	230	3500	337x417x(H)85



239292

	min Ø140 mm	3500 W
	max Ø280 mm	230 V



See movie

### INDUCTION HOT PLATE DISPLAY LINE

- Unique induction hot plate with a rectangular induction coil which allows multiple pans to be kept warm simultaneously.
- Power adjustable in 11 steps by means of a knob.
- Temperature range: 40-100°C.
- Equipped with electronic protection against overheating.

code	V	W	mm
209523	230	1000	455x333x(H)62



209523

1000 W
230 V





 min Ø140 mm 3500 W  
 max Ø280 mm 230 V

239711



**INDUCTION COOKER MODEL 3500 D**

- Digital power, temperature and timer setting via touch-sensitive controls.
- Stainless steel housing.
- With easily cleanable grease filter and double ventilation.
- Suitable for pans with a minimum Ø of 140 mm and a maximum of 280 mm.
- Height adjustable feet.

code	V	W	mm
239711	230	3500	340x440x(H)120



239773

**WOK**

- 3-ply material
- With stainless steel handle with softgrip
- With stainless steel lid
- Specifically for use with 239766



code	mm
239773	Ø360x(H)180



239681



**INDUCTION WOK MODEL 3500**

- Ideal for preparing nutritious meals.
- Stainless steel housing.
- With easily cleanable grease filter.
- Digital power setting.
- Settings immediately respond to high-low.
- Only suitable for use with wok pan 239773.

code		V	W	mm
239766	induction unit	230	3500	340x450x(H)120
239681	induction wok+wok pan	230	3500	340x450x(H)120 + Ø360



removable and cleanable air filter



3500 W  
230 V

239766



	min Ø140 mm	5000 W
	max Ø280 mm	400 V

239322



	min Ø140 mm	3500 W
	max Ø320 mm	230 V

239698

### INDUCTION COOKER MODEL 5000 D

- Digital power, temperature and timer setting via touch-sensitive controls.
- Stainless steel housing.
- With easily cleanable grease filter and double ventilation.
- Suitable for pans with minimum Ø 140 mm and maximum Ø 280 mm.
- Height adjustable feet.
- Works on 380V, supplied without plug, an electrician is required for the installation.



code	V	W	mm
239322	400	5000	398x515x(H)168

### INDUCTION COOKER MODEL 3500 D XL

- Digital power, temperature and timer setting via touch-sensitive controls.
- Stainless steel housing.
- With easily cleanable grease filter and double ventilation.
- Suitable for pans with a minimum Ø of 140 mm and a maximum of 320 mm.
- Height adjustable feet.



code	V	W	mm
239698	230	3500	390x500x(H)120

### INDUCTION COOKER MODEL 7000

- Stainless steel housing with two hobs.
- Front hob has a maximum power of 5000W, when the front hob operates at 5000W the rear hob can only generate 2000W.
- Rear hob has a maximum power of 3500W only while the front hob doesn't exceed 3500W.
- Electronic protection against overheating.
- With adjustable metal feet and removable air filter.
- Works on 380V, supplied without plug, an electrician is required for the installation.



code	V	W	mm
239346	400	2x3500	405x698x(H)145

239346

	min Ø160 mm	2x 3500 W
	max Ø280 mm	400 V



  
 min Ø120 mm  
 max Ø260 mm  
 3500 W  
 230 V



239780

**INDUCTION COOKER MODEL 3500 M**

- Steplessly adjustable power dial.
- Stainless steel housing.
- Suitable for use with pans and frying pans from Ø 120 mm up to Ø 260 mm.

code	V	W	mm
239780	230	3500	327x425x(H)100

  
 min Ø120 mm  
 max Ø260 mm  
 3000 W  
 230 V



239315

**INDUCTION COOKER MODEL 3000 M**

- Steplessly adjustable power dial.
- Stainless steel housing.
- Suitable for use with pans and frying pans from Ø 120 mm up to Ø 260 mm.

code	V	W	mm
239315	230	3000	327x420x(H)100

  
 min Ø120 mm  
 max Ø260 mm  
 2000 W  
 230 V



239230

**INDUCTION COOKER MODEL 2000**

- Very slim housing (32mm) with stainless steel frame.
- Ceramic glass surface.
- Touch-sensitive control.
- Suitable for pots up to 260 mm bottom size.

code	V	W	mm
239230	230	2000	296x370x(H)46

  
 min Ø120 mm  
 max Ø260 mm  
 1800 W  
 230 V



239209

**INDUCTION COOKER MODEL 1800**

- ABS housing.
- Digital power, temperature and timer setting.
- Settings immediately respond to high-low.
- Suitable for cooking pans with at least Ø 120 mm and at most Ø 260 mm, and frying pans with at least Ø 120 mm and at most Ø 200 mm.

code	V	W	mm
239209	230	1800	315x345x(H)70



### HOT TRAY

- GN 1/1 - aluminium.
- On insulated base.
- Automatically heats itself to 95°C.
- Can be used in combination with Thermobox Kitchen Line GN 1/1 and bigger (707906, 707968, 707951, 707944)



209509

code	V	W	mm
209509	230	190	530x325x(H)30

### INDUCTION HEATER 800W

- Black crystal glass top surface and plastic housing.
- Power regulation adjustable in 10 steps, fitted with electronic overheating protection.
- Control panel with LED display and touch control, can be mounted in a countersunk manner.
- Can be used as a heater chafing dishes equipped with special adapter.
- Also suitable for built-in installation with the optional separately available ring (239186).

code	mm	V	W
239193	Ø245x(H)68	230	800
239186	Mounting ring stainless steel		



239193



239186



**NEW!**

### QUARTZ HEATED COUNTERTOP DISPLAY TWO LEVELS

- Stainless steel housing, tempered glass sides, curved acrylic glass doors and mirror back panel.
- Access via two curved glass doors at the front.
- The shelves fit up to 4 GN1/2 containers.
- Fitted with two quartz heating elements and an electric heating plate at the bottom.
- With mechanical temperature controller.
- Fitted with lighting at the top.
- Temperature range: 30 up to 90°C

code	mm	V	W
233962	625x467x(H)650	230	550



233962



### HEATED COUNTERTOP CABINET

- Fitted with door at the back and curved front glass.
- Lightbox with room for promotional graphics.
- Stainless steel housing.
- Internal lighting in the ceiling.
- With 3 chrome plated shelves, adjustable in height.
- Temperature controller and display.
- Temperature range: 30 up to 90°C.

code	mm	V	W
233740	97 Liter 460x448x(v)785	230	800



233740





233726



233733

### HEATED COUNTERTOP DISPLAY THREE LEVELS

- Fitted with double glazing and curved front glass.
- Access via two sliding doors at the back.
- Stainless steel housing.
- Fitted with LED lighting at the top.
- With 3 chrome plated shelves, adjustable in height.
- Temperature controller and display.
- Temperature range: 30 up to 90°C

code		mm	V	W
233726	120 Liter	678x568x(v)686	230	1100
233733	160 Liter	857x568x(v)686	230	1500



273982



### HEATED COUNTERTOP DISPLAY SINGLE LEVEL

- Tempered glass sides and curved glass front.
- Stainless steel housing.
- With infrared heating.
- Large glass door in the rear, full access to the inside.
- Easy to clean.
- With removable crumb tray.
- Temperature adjustable up to 85°C.
- Includes fine mesh GN 1/1 grid suitable for small products.

code		mm	V	W
273982	single level	554x376x(v)311	230	400



273999



### HEATED COUNTERTOP DISPLAY TWO LEVELS

- Tempered glass sides and curved glass front.
- Stainless steel housing.
- With infrared heating.
- Large glass door in the rear, full access to the inside.
- Easy to clean.
- With removable crumb tray.
- Temperature adjustable up to 85°C.
- Includes 2 fine mesh GN 1/1 grids suitable for small products.

code		mm	V	W
273999	double level	554x376x(v)432	230	400

**NEW!**



273869



273876



273883



273890



**RISE AND FALL HEAT LAMP CONICAL**

- Thanks to the adjustable cord this heat lamp is very flexible, the length of the cord is adjustable from 70 to 150 cm.
- The amount of heat provided can be changed by adjusting the length of the cord.
- On/off switch located on top of the lamp.
- The included light bulb is shatterproof, making it suitable for keeping food warm.

code	V	W	mm	colour
273869	230	250	Ø275x(H)250	Silver
273876	230	250	Ø275x(H)250	Copper

**RISE AND FALL HEAT LAMP CYLINDRICAL**

- Thanks to the adjustable cord this heat lamp is very flexible, the length of the cord is adjustable from 70 to 150 cm.
- The amount of heat provided can be changed by adjusting the length of the cord.
- On/off switch located on top of the lamp.
- The included light bulb is shatterproof, making it suitable for keeping food warm.

code	V	W	mm	colour
273883	230	250	Ø175x(H)250	Silver
273890	230	250	Ø175x(H)250	Copper

**NEW!**



919217

**INFRARED HEAT BULB**

- Infrared replacement bulb for heat lamps.
- Shatterproof, with normal fitting (E27).

code	V	W	mm
919217	230	250	Ø125x(H)170

**NEW!**



919200

**INFRARED HEAT BULB**

- Infrared replacement bulb for heat lamps.
- Shatterproof, with normal fitting (E27).

code	V	W	mm
919200	230	250	Ø125x(H)170



273906

**2 LAMP INFRARED FOOD WARMER BRIDGE**

- Designed to keep food warm between preparing and serving.
- Height is easily adjustable.
- Shatterproof lamps included.

code	V	W	mm
273906	230	500	453x360x(H)590/790



## SOUS-VIDE SYSTEM

- Culinary system in which vacuum-sealed food is cooked at a precisely controlled temperature.
- Ideal for à la carte restaurants.
- Exceptionally suitable for preparation outside peak times.
- Consistently high quality results.

- High precision thermostat adjustable (0,1°C) from 35° to 90°C.
- Housing made entirely of stainless steel.
- Can be sealed air- and watertight due to the lid with silicone rim.



see movie

**S.S.**  
stainless steel

GN 2/3  
400 W  
230 V



225264



225448

GN 1/1  
600 W  
230 V

### SOUS-VIDE SYSTEM GN 2/3

- Equipped with handles.
- Stainless steel spacer with 4 compartments included.

code	liter	V	W	mm
225264	13	230	400	363x335x(H)290

### SOUS-VIDE SYSTEM GN 1/1

- Equipped with handles and drain tap.
- Stainless steel spacer with 6 compartments included.

code	liter	V	W	mm
225448	20	230	600	600x330x(H)300



### VACUUM COOKING BAGS

- Suitable for sous vide cooking.
- 2-ply, inside layer 60 µm food contact approved Polyethylene, outside layer 15µm Polyamide (Nylon). Total thickness is 75 µm.
- The used materials act as an UV filter.
- Bags can be used in temperatures from -20° up to 110°C.
- Suitable for chamber vacuum packing machines.

code		mm
970676	100 pieces	150x200
970652	100 pieces	150x250
970683	100 pieces	200x300
970669	100 pieces	250x350
970690	100 pieces	300x400
971314	50 pieces	350x450
971321	50 pieces	400x400
971338	50 pieces	380x500





### IVIDE CIRCULATOR STICK

- The whole body is IPX7 (submersion) water resistant.
- For safety the sous vide stick turns off when removed from the water bath.
- WiFi control possible, app available for iOS and Android devices.
- The app helps users calculate the perfect time and temperature, pre-loaded with over 600 recipes.
- Temperature can be set between 25°C and 90°C in 0,1°C increments.
- Can heat and circulate up to 20 liters of water.
- Can circulate 8 liters of water per minute.
- Bright screen shows the working temperature and time, easy to operate.

code	V	W	mm
224076	230	800	98x158x(H)350



224076



### POLYSCIENCE® CHEF SERIES SOUS VIDE THERMAL CIRCULATOR

- Water circulation provides maximum consistency (compared to non-stirred devices).
- Can be applied to the virtually any vessel by means of a clamp.
- Best performances up to 45 litres.
- Working temperature 20°C to 95°C, accuracy 0,05°C.
- Timer can be set up to 99 hours.
- Low Level water protection, device switches off the Sous Vide in case of accidental use without water.
- Control cooking liquid circulation level by easily adjustable pump pressure outlet.
- Maximum pressure flow rate of 12 litres per minute.
- Dedicated temperature control enables you to quickly set or adjust cooking temperature.
- Temperature sensor to prevent overload and overheating.
- Detachable power leads, both UK and European plugs included.

code	V	mm
225608	230	98x187x(H)359



**NEW!**

225608



**NEW!**



THERMAL PROCESSING



222997

**IVIDE PLUS SOUS VIDE STICK**

- High precision sous vide thermal circulator with temperature control.
- 4inch Touch Screen interface.
- Designed to fit to any round or flat cooking vessel with a minimum depth of 16.5cm by means of a clamp.
- Best performances up to 80 litres.
- Working temperature 5°C to 99°C, accuracy 0.07°C.
- Timer can be set between 1 minute and 99 hours.
- Multiple Machines can be managed from the App.
- Offers exceptional temperature stability.
- Low level water protection device switches off the sous vide in case of accidental use without water.
- Circulating pump to eliminate cold and hot spots.
- Temperature sensor to prevent overload and overheating.
- Carry Case as Standard.
- IPX7, can withstand splashes and accidental submersion.

**APP:**

- Precise temperature control from anywhere.
- A collection of over 600 recipes.
- Our Sous Vide Calculator: We've done all the testing and research for you, which means no more scouring the internet for information.
- Recipe Memory: Store your own times and temperatures.
- Cook history: For greater HACCP control store your last cook 10 times and temperatures.
- Multi device cooking: Control Several cookers form one app.
- Notifications to confirm when the water is at temperature, and the food is cooked. Cook time complete, don't worry the app will keep the food at the optimum temperature for holding.
- Multi-language Control: The first ever multilingual sous vide cooking app.

code	V	W	mm
222997	230	2200	130x145x(H)330



**EMBOSSED VACUUM BAGS**

- 2-ply, inside layer 60 µm food contact approved Polyethylene, outside layer 15µm Polyamide (Nylon). Total thickness is 75 µm.
- The used materials act as an UV filter.
- Embossing improves the air flow out of the bag during the vacuum packing process.
- Bags can be used in temperatures from -20° up to 100°C.
- Suitable for chamber and external vacuum packing machines.

code		mm
971017	100 pieces	150x250
971048	100 pieces	150x400
971024	100 pieces	200x300
971055	100 pieces	250x350
971031	100 pieces	300x400
971000	50 pieces	400x500

## LOW TEMPERATURE OVEN

- Designed for slowly preparing or regenerating food, by means of a very accurately set and controlled process.
- With core temperature probe, separately adjustable.
- Recessed handles in the sides.
- Easy to clean door seal.
- Oven chamber is heated on 4 sides, uniformly distributing the heat throughout the chamber.
- Energy efficient due to extra insulation.
- Seamless oven chamber with rounded corners, easy to clean.

- Temperature adjustable by 1 degree increments - oven chamber up to 120°C, core temperature and keep warm up to 100°C.
- Door hinges left or right, easy to convert.
- Digital setting and readout of time, set temperature, and current core/chamber temperatures.
- Stainless steel pan and tray holder, suitable for GN 1/1 containers, grids and trays as well as 600x400 mm bakery trays, on 3 levels.



see movie

225479

### LOW TEMPERATURE OVEN



code	V	W	mm
225479	230	1200	495x690x(H)415





240403

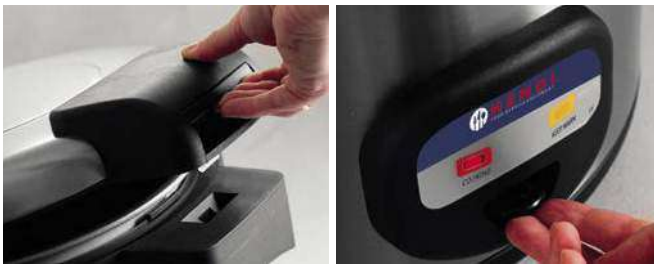

**RICE COOKER & WARMER**

- Suitable for 30 cups (180ml) of dry rice.
- Cooks rice and keeps it warm automatically.
- Measuring cup, rice spoon and silicone non-stick pad included.
- When keeping warm the sides of the pan are heated as well.



code	liter	V	W	mm
240403	5,4	230	1950	455x455x(H)380



240410

**RICE COOKER WITH STEAMER COOKING FUNCTION**

- Cooks rice and keeps it warm automatically.
- Suitable for 10 measuring cups of dry rice.
- Plastic steam basket included to use during steam function.
- Measuring cup and rice spoon included.
- Easy to clean thanks to removable aluminium pan.



code	liter	V	W	mm
240410	1,8	230	700	Ø280x(H)285



**NEW!**



238486



**SMOKE OVEN ELECTRIC**

- The smoke oven is ideal for smoking a variety of foods such as fish, beef, ham and vegetables.
- Made of stainless steel, with a magnetically closing double-insulated door.
- Temperature adjustable with a thermostat, thermometer integrated in door.
- Equipped with a hot air vent on the rear.
- Supplied with 3 grids (400x279mm) and 3 meat hooks.

code	mm	W
238486	540x380(H)720	1600



**NEW!**

199961



199978



199985



199800



199787



199770

**SMOKE INFUSER**

- The aluminium body functions as a heat sink, cooling the smoke before expelling it.
- Wood requires no pre-soaking prior to smoking.
- Can also be used with tea or spices.
- Removable smoking chamber with integrated filter.
- Flexible rubber hose (30 cm long) for easy injection of smoke into resealable bags and containers.
- Compact and lightweight enough to use with one hand.
- Gentle enough for use on delicate fruits and vegetables without changing their texture or temperature.
- Powered by 2 AA batteries, not included.
- Wood or herbs for smoking not included.

code	mm
199961	Ø68x(H)158

**GLASS DOME**

- Ideal to use in combination with the smoke infuser, create a spectacular way to present dishes to customers.

code	mm
199978	Ø245x(H)150

**SMOKING GUN PRO - SAGE COMMERCIAL**

- The smoking gun pro allows you to infuse a variety of foods and drinks with natural smoky flavours like applewood & hickory without adding any heat.
- Removable stainless steel combustion chamber and smoking barrel, can't be melted by blowtorch use and prevents resin build up.
- The 50 cm flexible rubber hose is easy to install and remove.
- Heavy-duty removable fan - will not melt when heated. Fan can be removed for cleaning with the supplied Allen key.
- Efficient, low-noise motor with air flow adjustment knob.
- Runs on 4 AA batteries (included).
- Includes two 1/2 OZ sample jars of PolyScience® Hickory and Apple Wood Smoking Sawdust.

code	mm
199985	150x80x(H)165

**AROMATIC WOOD CHIPS**

- For hot smoking in a smoke box or smoke oven.

code		type
199800	Oak wood	1000ml bag
199824	Bourbon wood	1000ml bag
199831	Hickory wood	1000ml bag
199848	Applewood	1000ml bag
199855	Cherry wood	1000ml bag
199862	Beech wood	1000ml bag
199893	Mesquite wood	1000ml bag

**SMOKER WOOD DUST**

- Very fine aromatic oak chips.
- For use with cold smoke infusers/smoking guns.

code	type
199787	500 g.

**SMOKER WOOD DUST**

- Very fine aromatic wood chips.
- For use with cold smoke infusers/smoking guns.
- Set of four different wood types: cherry, oak, hickory and mesquite.

code	type
199770	4 x 250ml tins

**THE CONTROL °FREAK™ INDUCTION HOB**

- The Control °Freak™ induction cooking system is the first of its kind to accurately measure, set and hold 397 cooking temperatures from 30-252°C. The unique real-time sensing system uses a through-glass sensor to directly measure surface temperatures and a Probe Control™ remote thermometer to precisely control the temperature of both water and fat-based liquids. The Intensity function gives incredible control over the heat up speed to the set temperature. The Create function stores frequently used custom temperature profiles for simple one-touch recall.
- Temperature range of 30-250°C, precise temperature control within 0,5°C.
- Power can be set between 100-1800W.
- Both temperature probes have a resolution of 0-300°C.
- 72 hour timer with 'Repeat, Continue, Keep Warm and Stop Cooking' functions.
- Control cooking liquid circulation level by easily adjustable pump pressure outlet.
- Durable stainless steel housing with ceramic glass induction hob.
- Dual fan cooling system.
- Clear digital control panel with color display.
- USB port allows for software updates.
- Detachable power leads, both UK and European plugs included.

code	V	W	mm
239216	230	1800	350x470x(H)110



239216



**ANTI-GRIDDLE™**

- The PolyScience® Anti-Griddle™ is a traditional cooktop with an amazing twist: the device quickly freezes sauces and purees instead of heating them! Develop solid or semi-frozen creations with stable, crunchy surfaces and cool, creamy centres. The dual-textures create a surprising and unique experience plates. On buffets and at catering events, the Anti-Griddle™ always attracts diners when preparing a frozen appetizer or dessert right in front of their eyes. Within 5-10 minutes the Anti-Griddle™ surface will reach a temperature at -34°C.
- Durable housing out of stainless steel with non-slip feet.
- The freezing surface is made of stainless steels and measures 38,1x22,8 cm.
- Fitted with carrying handles and supplied with freezing surface cover.

code	V	mm
274248	230	403x477x343



274248





**GRILL MESH NON-STICK PTFE**

- For use in combination with barbecues, grills and food dehydrators.

code	thickness (mm)	packed per	mm
678008	1	5	400x300
678015	1	5	530x325
678022	1	5	600x400

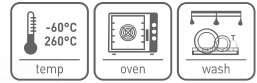

678015

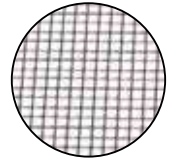

6 trays  
500 W  
230 V



see movie



229002



**FOOD DEHYDRATOR KITCHEN LINE**

- For drying fruits, vegetables, herbs, meat, fish, etc.
- Automatic fans circulate the warm air for an evenly dried result.
- Fitted with 6 or 9 stainless steel 330x305 mm trays which can hold up to 500 grams each.
- Trays are evenly spaced at 35 mm intervals and are easy to remove and clean.
- Inside of the housing and the door are made of BPA-free materials.
- Thanks to the transparent door you can keep an eye on the drying process.
- Delivered with a transparent pad which can be used to catch the residue on the bottom of the dryer or to make fruit leather.
- Temperature adjustable from 35° to 70°C.

code		V	W	mm
229002	6 trays	230	500	450x345x(H)315
229019	9 trays	230	700	450x345x(H)415



9 trays  
700 W  
230 V

229019

Easy controls



Easy to open



With fine mesh for drying small items





# NEW!



## FOOD DEHYDRATOR PROFI LINE

- Stainless steel housing.
- For drying fruits, vegetables, herbs, meat, fish, etc.
- Digital control panel.
- Timer adjustable up to 24 hours by 30 minute increments.
- Temperature adjustable from 35°C to 75°C by 5° increments.
- Silent fans circulate the warm air for an evenly dried result, without the need to rotate the trays.
- Fitted with 6 stainless steel grids, 305x330 mm each.
- Grids are evenly spaced and are easy to remove and clean.
- Thanks to the transparent door you can keep an eye on the drying process.

code		V	W	mm
<b>229033</b>	6 trays	230	550-650	340x450x(H)311

6 trays  
600 W  
230 V



229033

## FOOD DEHYDRATOR PROFI LINE

- Stainless steel housing.
- For drying fruits, vegetables, herbs, meat, fish, etc.
- Digital control panel.
- Timer adjustable up to 24 hours by 30 minute increments.
- Temperature adjustable from 35°C to 75°C by 5° increments.
- Silent fans circulate the warm air for an evenly dried result, without the need to rotate the trays.
- Fitted with 10 stainless steel grids, 400x395 mm each.
- Grids are evenly spaced and are easy to remove and clean.
- Thanks to the transparent door you can keep an eye on the drying process.

code		V	W	mm
<b>229026</b>	10 trays	230	1000	417x535x(H)430

10 trays  
1000 W  
230 V



229026



See movie

Drying chamber with space for 10 trays



Easy to operate digital control panel



Residu pad included



## DEEP FRYERS MASTERCOOK DIGITAL

- The Mastercook range of tabletop deep fryers is made of 18/0 stainless steel.
- Element with switch-off function when removed.
- Oil container with a V-shaped bottom ensures an optimal cold zone, increases the useful life of the oil.
- Clear digital control panel with temperature and timer function.
- Protected against overheating by means of a re-settable thermal fuse.
- A frying basket with extra long handle turns this model into a fine piece of equipment for intensive use.
- All deep fryers come with frying basket(s) and lid(s).

# NEW!

18/0  
stainless steel



207345



207352

### DEEP FRYER MASTERCOOK DIGITAL - 8 L

code	liter	V	W	mm
207345	8	230	3500	300x455x(H)345

### DEEP FRYER MASTERCOOK DIGITAL - 2 X 8 L

code	liter	V	W	mm
207352	2x8	230	2x3500	605x455x(H)345



207369



207376

### DEEP FRYER MASTERCOOK WITH DRAIN TAP DIGITAL - 8 L

code	liter	V	W	mm
207369	8	230	3500	300x515x(H)345

### DEEP FRYER MASTERCOOK WITH DRAIN TAP DIGITAL - 2 X 8 L

code	liter	V	W	mm
207376	2x8	230	2x3500	605x515x(H)345

## DEEP FRYERS MASTERCOOK

- The Mastercook range of tabletop deep fryers is made of 18/0 stainless steel.
- Element with switch-off function when removed.
- Oil container with a V-shaped bottom ensures an optimal cold zone, increases the useful life of the oil.
- The clear controls with temperature pilot lights can be found on top of the equipment.
- Protected against overheating by means of a re-settable thermal fuse.
- A frying basket with extra long handle turns this model into a fine piece of equipment for intensive use.
- All deep fryers come with frying basket(s) and lid(s).

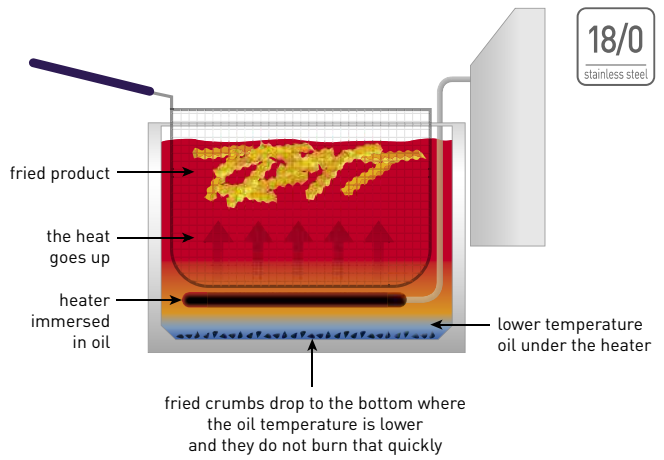

**DEEP FRYER MASTERCOOK - 8 L**

code	liter	V	W	mm
207208	8	230	3500	300x455x(H)345



**DEEP FRYER MASTERCOOK - 2 X 8 L**

code	liter	V	W	mm
207307	2x8	230	2x3500	605x455x(H)345



**DEEP FRYER MASTERCOOK WITH DRAIN TAP - 8 L**

code	liter	V	W	mm
209202	8	230	3500	300x515x(H)345



**DEEP FRYER MASTERCOOK WITH DRAIN TAP - 2 X 8 L**

code	liter	V	W	mm
209301	2x8	230	2x3500	605x515x(H)345



18/0

stainless steel



205808

4 liter  
3000 W  
230 V

205815

6 liter  
3300 W  
230 V

205822

### DEEP FRYER BLUE LINE

- Housing and oil tank made of stainless steel.
- Removable element with switch-off function when removed.
- Removable oil container, making it easier to clean.
- Heating indication lamp to show if the heating element is operating.
- The temperature can be set up to 190°C.
- A security thermostat ensures the deep fryer does not overheat.
- Overheat protection with reset for extra protection.
- A frying basket with heat insulated and extra long handle.
- Cold zone to protect oil quality.
- Supplied with frying basket and lid.

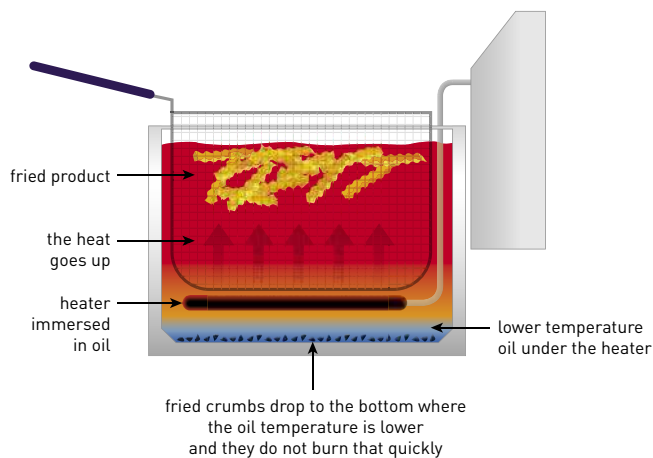

code	liter	V	W	mm
205808	4	230	3000	217x380x(H)300
205846	2x4	230	2x3000	470x420x(H)330
205815	6	230	3300	265x430x(H)290
205853	2x6	230	2x3300	550x430x(H)290
205822	8	230	3500	265x430x(H)345
205839	2x8	230	2x3500	550x430x(H)345







8 liter  
3500 W  
230 V

2x 8 liter  
2x 3500 W  
230 V

205839



2x 6 liter  
2x 3300 W  
230 V

205853

Cold zone to protect oil quality



Removable oil container, making it easier to clean



Frying basket with heat insulated and extra long handle



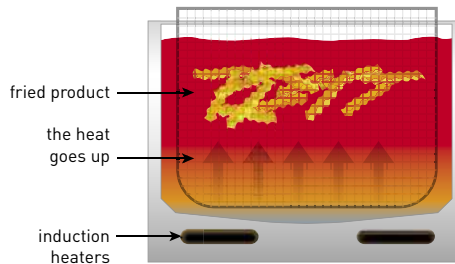

8 liter  
3500 W  
230 V



215012

2x 8 liter  
2x 3500 W  
230 V



215029

**INDUCTION DEEP FRYER KITCHEN LINE**

- Precise temperature control, induction technology keeps the oil at exactly the set temperature.
- With countdown timer.
- Efficient heat transfer.
- Stainless steel housing for easy cleaning.
- Overheating protection.
- Displays set temperature of the oil.
- Supplied with frying basket and lid.

code	liter	V	W	mm
215012	8	230	3500	290x485x(H)406

**INDUCTION DEEP FRYER KITCHEN LINE - DOUBLE**

- Precise temperature control, induction technology keeps the oil at exactly the set temperature.
- With two countdown timers.
- Efficient heat transfer.
- Stainless steel housing for easy cleaning.
- Overheating protection.
- Display of set temperature of the oil.
- Supplied with two frying baskets and lids.

code	liter	V	W	mm
215029	8+8	230	3500+3500	580x485x(H)406

Drain tap makes emptying easy



With filter for the induction motor



Convenient edge for hanging basket



**NEW!**



205914



**DOUGHNUT DEEP FRYER 12L**

- Ideal for frying doughnuts, angel wings, beignets, Dutch doughnuts and other fried dough pastries.
- Entirely made of stainless steel, comes with two frying grids (354x383mm) with cool-touch handle, a heater guard and a lid that can also serve as a drip tray.
- Easy to use and clean, suitable for intensive use and high outputs.
- Fitted with a large welded oil tank (400x400x(H)160 mm) with a max. capacity of 12 liters.
- Tank equipped with drain tap and min/max oil level markings, has a 'cold zone' to improve the oils usetime.
- Removable heat element with switch-off function when removed and overheat protection.
- The temperature can be set from 50° up to 190°C.
- Heating indication lamp to show if the heating element is operating.
- With rubber anti-slip feet.



code	liter	V	W	mm
205914	12	230	3000	630x860x(H)360





**GRIDDLES BLUE LINE**

- Stainless steel housing.
- The hard chromed surface (9mm plate) facilitates cleaning.
- With removable dripping tray and high backsplashes.
- Stepless thermostat adjustable up to 300°C.
- Overheating protection.
- Suitable for continuous use.
- Power switch with integrated indication lamp.
- Non-slip feet.

**GRIDDLE BLUE LINE**

- Griddle area 330x270 mm, entirely smooth.

code	V	W	mm
203125	230	2000	450x300x(H)225



203125



203156

**GRIDDLE BLUE LINE**

- Griddle area 518x328 mm, left 259 mm smooth and right 259 mm ribbed.

code	V	W	mm	
203156	1/2 flat, 1/2 ribbed	230	2400	550x380x(H)240

**GRIDDLE BLUE LINE**

- Griddle area 518x328 mm, entirely ribbed.

code	V	W	mm	
203170	entirely ribbed	230	2400	550x380x(H)240

**GRIDDLE BLUE LINE**

- Griddle area 518x328 mm, entirely smooth.

code	V	W	mm	
203149	flat	230	2400	550x380x(H)240

**GRIDDLE BLUE LINE**

- 2 independent working areas, 2 heating indication lamps.
- Griddle area 688x410 mm, left 462 mm smooth and right 226 mm ribbed.

code	V	W	mm	
203163	2/3 flat, 1/3 ribbed	230	3500	720x530x(H)250

**GRIDDLE SCRAPER**

code	mm
855201	100x315

855201



855218

**SPARE BLADE FOR 855201**

- 5 pieces

code
855218





## TEPAN-YAKI GRIDDLE

- Detachable, steplessly adjustable plug thermostat.
- Sturdy handles for safe transport.
- The Tepan-Yaki griddle is easy to clean.
- Griddle surface features a non-stick coating.



## TEPAN-YAKI GRIDDLE

- Griddle surface dimensions: 439x228mm.

code	V	W	mm
238608	230	1800	439x230x(H)110

## TEPAN-YAKI GRIDDLE

- Griddle surface dimensions: 893x217mm.

code	V	W	mm
238301	230	1800	900x230x(H)110



## PARTY PAN

- Aluminium with non-stick coating.
- Removable thermostat.
- Suitable for frying, roasting and keeping hot.
- Including lid with clear glass and two insulated handles.



code		V	W	mm
239506	inner pan 400x(H)50mm	230	1400	Ø500x(H)190
239605	inner pan 550x(H)60mm	230	1600	Ø620x(H)190



## CONTACT GRILLS

- Cast-iron enamelled grills.
- Stainless steel frame.
- With wire brush.
- Fitted with fat tray and backslash.

- Thermostat continuously adjustable up to a maximum of 300°C, with indicator light.
- With lifted top (H)530 mm.



263501



263600

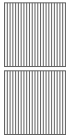

### CONTACT GRILL - SINGLE VERSION

- Grill surface 220x230 mm

code	V	W	mm
263501	230	1800	290x370x(H)210



### CONTACT GRILL - SINGLE VERSION

- Grill surface 220x230 mm

code	V	W	mm
263600	230	1800	290x370x(H)210



263655



263662

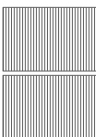

### CONTACT GRILL "PANINI"

- Grill surface 340x230 mm

code	V	W	mm
263655	230	2200	430x370x(H)210

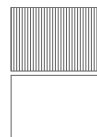

### CONTACT GRILL "PANINI"

- Grill surface 340x230 mm

code	V	W	mm
263662	230	2200	430x370x(H)210



3600 W  
230 V

263709

**CONTACT GRILL - DOUBLE VERSION**

- Thermostats independently adjustable
- Grill surface bottom plate 475x230 mm

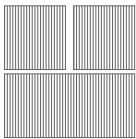

code	V	W	mm
263709	230	3600	570x370x(H)210



3600 W  
230 V

263808

**CONTACT GRILL - DOUBLE VERSION**

- Thermostats independently adjustable
- Grill surface bottom plate 475x230 mm

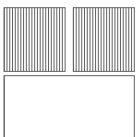

code	V	W	mm
263808	230	3600	570x370x(H)210



3600 W  
230 V

263907

**CONTACT GRILL - DOUBLE VERSION**

- Thermostats independently adjustable
- Grill surface bottom plate 475x230 mm

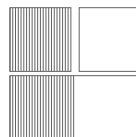

code	V	W	mm
263907	230	3600	570x370x(H)210





## SALAMANDERS

S.S.  
stainless steel

THERMAL PROCESSING



264607



Removable grid and dripping tray



Height smoothly adjustable

### SALAMANDER 450

- Type 450 - stainless steel frame.
- Ideal for grilling or keeping dishes/sandwiches warm and crisp.
- Thermostat continuously adjustable up to a maximum of 300°C, with indicator lights.
- Adjustable height by means of smoothly running lifting system.
- Removable dripping/crumb tray with 440x320 mm grid.

code	V	W	mm
264607	230	2800	480x520x(H)530

### SALAMANDER 600

- Type 600 - stainless steel frame.
- Ideal for grilling or keeping dishes/sandwiches warm and crisp.
- Thermostat continuously adjustable up to a maximum of 300°C, with indicator lights.
- 2 independent heating areas.
- Adjustable height by means of smoothly running lifting system.
- Removable dripping/crumb tray with 590x350 mm grid.

code	V	W	mm
264706	230	3600	600x520x(H)530



264706



Removable grid and dripping tray



Height smoothly adjustable





**NEW!**

3645 W  
230 V

**SALAMANDER WITH QUARTZ INFRARED HEATING ELEMENTS**

- It is possible to place GN1/1 trays in the chamber.
- Ideal for grilling or heating up dishes or sandwiches.
- With top & bottom Quartz infrared heating element.
- Fitted with thermostat, 15 min. timer and indicator lamp.
- 3 possible grid heights, grid handles fitted with heat shield.
- With crumb tray.
- Conforms to the IPX3 norm.



264409

code	V	W	mm
264409	230	3645	689x397x(H)318

**SALAMANDER WALL MOUNTABLE**

- Conforms to the IPX4 norm.
- Can be installed against the wall without requiring additional brackets.
- Ideal for grilling or heating up dishes or sandwiches.
- Continuously adjustable from 50°C to 300°C.
- With top heating element.
- Fitted with thermostat, 30 min. timer and indicator lamp.
- 4 possible grid heights, grid handles fitted with heat shield.
- With crumb tray.

2000 W  
230 V



Wall mountable without the use of any additional brackets

264119

code	V	W	mm
264119	230	2000	610x310x(H)280

**SALAMANDER 580**

- Type 580.
- Ideal for grilling or heating up dishes or sandwiches.
- Continuously adjustable from 50°C to 300°C.
- With top heating element.
- Fitted with power regulator, 30 min. timer and indicator lamp.
- 4 possible grid heights.
- With crumb tray.
- Interior dimensions: 426x345x(H)257 mm.

2200 W  
230 V



264201

code	V	W	mm
264201	230	2200	580x413x(H)376

**SALAMANDER 800**

- Type 800.
- Ideal for grilling or heating up dishes or sandwiches.
- Continuously adjustable from 50°C to 300°C.
- With top heating element.
- Fitted with power regulator, 30 min. timer and indicator lamp.
- 4 possible grid heights.
- With crumb tray.
- Interior dimensions: 646x408x(H)337 mm.

3600 W  
230 V



264300

code	V	W	mm
264300	230	3600	800x472x(H)456



## SAUSAGE ROLLING GRILLS

- Stainless steel housing.
- Quick heating and heat recovery.
- Non-stick coated rollers.
- Removable easy-to-clean drip tray.
- The rollers have a usable width of 42 cm.
- Adjustable temperature up to 150°C.



268506

### SAUSAGE ROLLING GRILL - 7 ROLLERS

code	V	W	mm
268506	230	740	520x325x(H)175



268605

### SAUSAGE ROLLING GRILL - 9 ROLLERS

code	V	W	mm
268605	230	940	520x400x(H)175



268704

### SAUSAGE ROLLING GRILL - 11 ROLLERS

code	V	W	mm
268704	230	1180	520x477x(H)175



268735

### SAUSAGE ROLLING GRILL - 14 ROLLERS

code	V	W	mm
268735	230	1480	520x591x(H)175

Hotdog stand on page 94-95



## SAUSAGE WARMER

S.S.  
stainless steel



240502

### SAUSAGE WARMER 10 LITER

- Stepless thermostat temperature control up to 85 °C.
- With handles for transport.
- Lid has a stay-cool handle.

code	V	W	mm
240502	230	1000	330x280(H)250



Sausages placed on the special grid are heated by steam, it prevents sausages from being overcooked



265000

### SAUSAGE WARMER

- Heats hotdog sausages and keeps them warm.
- Stainless steel housing, sausage container made of anodized aluminum and glass.
- With adjustable power.

code	V	W	mm
265000	230	500	240x300x(H)385





## BAIN-MARIE GASTRONORM



### BAIN-MARIE KITCHEN LINE

- Gastronorm 1/1.
- Thermostat adjustable up to 85°C.
- Stainless steel water container with smooth edges which make it easier to keep the container clean.
- With on/off switch, indicator light.
- Supplied without GN containers.
- Suitable for gastronorm pans up to 150 mm deep.



code	V	W	mm
238905	230	1200	340x540x(H)250

### BAIN-MARIE KITCHEN LINE WITH DRAIN TAP

- Gastronorm 1/1.
- Continuous temperature settings up to 85°C.
- Stainless steel water container with smooth edges which make it easier to keep the container clean.
- With on/off switch, thermostat and indicator light.
- Supplied without GN containers.
- Suitable for gastronorm pans up to 150 mm deep.
- With drain tap.



code	V	W	mm
238912	230	1200	340x540x(H)250



### THERMOSYSTEM 1

- Enamelled pan Ø 185mm.
- Stainless steel bain-marie pan with lid.
- Fitted with power regulator and indicator light.



code	liter	V	W	mm
201107	4,2	230	200	265x265x(H)245

### THERMOSYSTEM 2

- 2 enamelled pans Ø 185 mm.
- 2 stainless steel bain-marie pans with lids.
- Fitted with two power regulators and indicator lights.



code	liter	V	W	mm
201206	2x4,2	230	400	505x265x(H)245



## CREPES AND WAFFLE MAKERS



212004

Including wooden spreader



### CRÊPE MAKER

- Designed for making crepes.
- Baking plate Ø400 mm made of cast iron with a non-stick coating.
- Very even heat distribution across the surface.
- With storage drawer 400x320x(H)30 mm.
- Including wooden spreader.
- Stainless steel housing.
- Thermostat continuously adjustable from 50 to 250°C.
- With protection from overheating and EGO thermostat.

code	V	W	mm
212004	230	3000	450x470x(H)240



212103

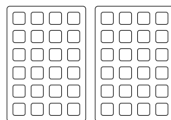

1500 W  
230 V

### WAFFLE MAKER 'LIÈGE'

- Liège waffles, two 4x6 rectangular patterns.
- Cast iron non-stick coated surface
- Thermostatic temperature control.
- Including waffle fork.
- Insulated handle.

code	weight (kg)	V	W	mm
212103	28	230	1500	320x437x(H)251



**NEW!**



212127

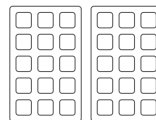

2200 W  
230 V

### WAFFLE MAKER 'BRUSSELS'

- Brussels waffles, two 3x5 rectangular patterns.
- Cast iron non-stick coated surface
- Thermostatic temperature control.
- Including waffle fork.
- Insulated handle.

code	weight (kg)	V	W	mm
212127	23	230	2200	320x437x(H)277



**NEW!**



212134

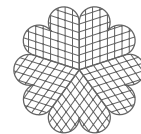

2200 W  
230 V

### WAFFLE MAKER 'HEART'

- Flower waffles, five conjoined heart-shaped patterns.
- Cast iron non-stick coated surface
- Thermostatic temperature control.
- Including waffle fork.
- Insulated handle.

code	weight (kg)	V	W	mm
212134	16	230	2200	320x437x(H)251

TOASTERS



**NEW!**

**CONVEYOR TOASTER SINGLE**

- One row of bread slices fit on the conveyor.
- Two separate heating elements.
- Suitable for continuous toasting of sliced bread.
- Supplied with front and back trays.
- Adjustable toasting time up to 5 minutes.

code	V	W	mm
261200	230	1340	288x418x(H)387

1340 W  
230 V



261200



2240 W  
230 V



**CONVEYOR TOASTER DOUBLE**

- Two rows of bread slices fit next to each other on the conveyor.
- Two separate heating elements.
- Suitable for continuous toasting of sliced bread.
- Supplied with front and back trays.
- Adjustable toasting time up to 3 minutes.

code	V	W	mm
261309	230	2240	418x368x(H)387



261309

# NEW!

3000 W  
230 V



262214



### MULTI TOASTER 6 TONGS

- 2 Layers with 6 toaster tongs - stainless steel.
- Infrared quartz tubes for prompt heating, temperature can reach maximum within 30 seconds. Tubes cool down in seconds.
- Switch for selecting different heating groups.
- 15 Minutes mechanical timer with bell.
- 6 Toaster tongs included.

code	V	W	mm
262214	230	3000	438x290x(H)402



### TOASTER TONG

code	mm
262801	100x340x(H)64



### SANDWICH TOASTER

- Stainless steel housing.
- Tongs fitted with insulated handles made of PF resin.
- Left and right slot separately operable.
- Timer with alarm adjustable to a maximum of 8 minutes.
- Removable crumb tray.

code	V	W	mm
261163	230	1200	300x200x(H)223



1200 W  
230 V

261163







26 liter  
1450 W  
230 V



281475

### SAMSUNG MICROWAVE PROGRAMMABLE 1780W

- Model: SAMSUNG CM1929A/XEU
- Housing made of stainless steel, door fitted with glass window.
- Chamber is fitted with a ceramic floor and light.
- Input power 3200W, output power 1780W.
- Power can be set in 5 levels: high (100%), medium (70%), low (50%), quick defrost (20%), slow defrost (10%).
- Microwave by means of two rotating microwave tubes in the ceiling.
- Digital touch control panel with option of saving 30 3-step programs.
- Digital display with countdown timer, can be set up to 25/40/50 minutes depending on the program.
- Program lock function to prevent accidental deletion of programs.
- Repeat function to run the last cycle again.
- One touch function which extends the cooking cycle with 30 seconds when touched.
- Program finish signal can be modified.
- With air filter cleaning reminder.
- Stackable, microwaves can stack on each other with the included support plate.
- Removable internal upper guard to ease cleaning.
- Weight: 32 kg.

code	liter	V	W	mm
281475	26	230	3200	464x557x(H)368

26 liter  
1600 W  
230 V



281482

### SAMSUNG MICROWAVE 1050W

- Model: SAMSUNG CM1099A/XEU
- Housing made of stainless steel, door fitted with glass window.
- Chamber is fitted with a ceramic bottom and light.
- Input power 1600W, output power 1050W.
- Power can be set in 5 levels: high (100%), medium (70%), low (50%), reduced (30%), defrost (15%).
- Microwave operates on a single microwave tube.
- With two knobs, for selecting power/function and for setting the timer.
- Timer can be set up to 35 minutes.
- Weight: 17,5 kg

code	liter	V	W	mm
281482	26	230	1600	517x412x(H)297



26 liter  
1780 W  
230 V



281390

### SAMSUNG MICROWAVE 1780W

- Model: SAMSUNG CM1919A/XEU
- Housing made of stainless steel, door fitted with glass window.
- Chamber is fitted with a ceramic bottom and light.
- Input power 3200W, output power 1780W.
- Power can be set in 5 levels: high (100%), medium (70%), low (50%), Quick defrost (20%), slow defrost (10%).
- Microwave operates on two microwave tube.
- With two knobs, for selecting power/function and for setting the timer.
- Digital display with countdown timer, can be set up to 50 minutes depending on the power level selected.
- "ONE TOUCH" function which extends the running program with 20 seconds when touched.
- Stackable, microwaves can be stacked on each other with the included support plate.
- With removable and cleanable air filter.
- Chamber dimensions: 370x370x(H)190 mm
- Weight: 32 kg

code	liter	V	W	mm
281390	26	230	3200	464x557x(H)368

26 liter  
1450 W  
230 V

**NEW!**

**S.S.**  
stainless steel



281499

### SAMSUNG MICROWAVE 1450W

- Model: SAMSUNG CM1519A
- Housing made of stainless steel, door fitted with glass window.
- Chamber is fitted with a ceramic bottom and light.
- Input power 3000W, output power 1450W.
- Power can be set in 5 levels: high (100%), medium (70%), low (50%), Quick defrost (20%), slow defrost (10%).
- Microwave operates on two microwave tube.
- With two knobs, for selecting power/function and for setting the timer.
- Digital display with countdown timer, can be set up to 50 minutes depending on the power level selected.
- "ONE TOUCH" function which extends the running program with 20 seconds when touched.
- Stackable, microwaves can be stacked on each other with the included support plate.
- With removable and cleanable air filter.
- Chamber dimensions: 370x370x(H)190 mm
- Weight: 32 kg

code	liter	V	W	mm
281499	26	230	3000	464x557x(H)368

### SAMSUNG MICROWAVE PROGRAMMABLE 1050W

- Model: SAMSUNG CM1089A/XEU
- Housing made of stainless steel, door fitted with glass window.
- Chamber is fitted with a ceramic floor and light.
- Input power 1600W, output power 1050W.
- Power can be set in 4 levels: high (100%), medium (70%), low (50%), defrost (30%)
- Microwave operates on a single microwave tube.
- Digital touch control panel with option of saving 20 3-step programs.
- Digital display with countdown timer, can be set up to 30 minutes.
- "ONE TOUCH" function which extends the running program with 30 seconds when touched.
- Program finish signal can be modified.
- Weight: 14,5 kg.

code	liter	V	W	mm
281451	26	230	1600	517x412x(H)294

26 liter  
1050 W  
230 V



281451





20 liter  
700 W  
230 V



See movie



281710

### MICROWAVE WITH GRILL

- Controlled with two knobs, timer and power/function separately adjustable.
- Input power 1050W, output power 700W microwave or 1000W grill.
- Timer can be set up to 35 minutes.
- Stainless steel front panel and transparent door.
- The coated chamber contains a glass turntable Ø255mm.
- Suitable for plates up to Ø280x(H)160mm.
- Chamber dimensions: 304x306x(H)206mm.
- Volume 20 liter.

code	liter	V	W	mm
281710	20	230	1050	440x330x(H)259



25 liter  
1000 W  
230 V



See movie



281352

### MICROWAVE 1000W

- Controlled with a single knob, time adjustable from 15 seconds to 6 minutes.
- Uses a rotating antenna under the chamber floor.
- Chamber made of stainless steel with a ceramic floor.
- Transparent door without a lock, easy to open.
- Input power 1550W, output power 1000W.
- Chamber dimensions: 327x346x(H)200 mm
- Volume 25 liter.

code	liter	V	W	mm
281352	25	230	1550	511x432x(H)311

25 liter  
1000 W  
230 V



281444

### MICROWAVE PROGRAMMABLE 1000W

- Easy to use control panel with 10 programmable buttons.
- Programmable up to 3 stages of cooking, memory capacity for 100 programs.
- Chamber made of stainless steel with interior light.
- Housing made of stainless steel.
- Suitable for plates up to Ø320 mm.
- Input power 1550W, output power 1000W.
- Energy feed through the bottom by use of a rotating antenna.
- Transparent door without a lock, easy to open.
- Chamber dimensions: 327x346x(H)200mm.
- Volume 25 liter.

code	liter	V	W	mm
281444	25	230	1550	511x432x(H)311



See movie

**S.S.**  
stainless steel

34 liter  
1000 W  
230 V

### MICROWAVE PROGRAMMABLE 1000W

- Easy to use control panel with 10 programmable buttons.
- Housing made of stainless steel.
- Microwave chamber made of stainless steel with a ceramic floor.
- Input power 1500W, output power 1000W.
- Transparent door without a lock, easy to open.
- Chamber dimensions: 370x385x(H)230 mm
- Volume 34 liter.

code	liter	V	W	mm
281413	34	230	1500	553x488x(H)343



281413



See movie

34 liter  
1800 W  
230 V

### MICROWAVE PROGRAMMABLE 1800W

- Easy to use control panel with 10 programmable buttons.
- Uses twin microwave generators.
- Housing made of stainless steel.
- Microwave chamber made of stainless steel with a ceramic floor.
- Input power 3000W, output power 1800W.
- Transparent door without a lock, easy to open.
- Chamber dimensions: 360x409x(H)225 mm
- Volume 34 liter.

code	liter	V	W	mm
281369	34	230	3000	574x528x(H)368



281369



## KEBAB GRILL & KNIFE



Motor can rotate both ways

Wide reflection screens

Equipped with 4 burners

Removable dripping tray

226001



### KEBAB GRILL GAS PROFI LINE

- For natural gas, can be converted to propane with included converter set.
- Fitted with thermocouple.
- Grill distance adjustment.
- Burners power 12 kW.
- Delivered with reflection screens.
- Grill length: 900 mm.
- Capacity: up to 80 kg.
- Weight 30 kg.

code	V	mm
226001	230	470x550x(H)1150





### CORDLESS KEBAB KNIFE ELECTRIC

- For slicing döner kebab, shawarma, gyro, etc..
- 2 stainless steel  $\varnothing$ 100 mm blades, 1 smooth and 1 serrated.
- Blade spins at 2600 RPM and can slice up to 60 kg/h.
- Easily adjustable slicing thickness from 0 mm up to 8 mm.
- Blade cover made of stainless steel ensures safety during cutting.
- Handle and motor housing made of anti-slip material.
- ON/OFF switch integrated with the housing.
- Charger with red and green light indicating battery level.
- Two 2,000 mAh battery packs included.
- Blade sharpening stone included.
- Weight 1 kg.

code	V	W	mm
267257	230	80	199x114x(H)184



267257

### KEBAB KNIFE ELECTRIC

- For slicing döner kebab, shawarma, gyro, etc.
- 2 stainless steel  $\varnothing$ 100 mm blades, 1 smooth and 1 serrated.
- Blade spins at 2600 RPM and can slice up to 60 kg/h.
- Easily adjustable slicing thickness from 0 mm up to 8 mm.
- Blade cover made of stainless steel ensures safety during cutting.
- Handle and motor housing made of anti-slip material.
- ON/OFF switch integrated with the housing.
- Overload protection with a reset button.
- Blade sharpening stone included.
- Weight 1 kg.

code	V	W	mm
267240	230	80	194x113x(H)173



267240



Stainless steel roller

### CHEESE-GRATING MACHINE

- Capacity of 30 kilos per hour.
- Functional and practical, stable body.
- Despite its small size, the device offers high performance.
- Ideal for grating Parmesan cheese and other hard cheeses.
- Motor is protected against overloading.
- Provided with grated cheese container 1,3 L.
- Speed: 1400 RPM.
- Cylinder diameter  $\varnothing$ 110x60 mm.
- Weight 8 kg.

code	V	W	mm	
226827	30 kg/h	230	380	280x250x(H)310



226827



## SPIRAL MIXERS

- Housing made of high-quality white-varnished stainless steel.
- Bowl, cover and spiral made of 18/10 stainless steel.
- With built-in timer.
- Movable thanks to 4 wheels of which 2 have brakes.



226209

Fitted with  
castor wheels

**NEW!**

### SPIRAL MIXER WITH FIXED BOWL - 10 L

- Model with fixed head and bowl.
- Bowl capacity: 10 liter.
- Bowl dimensions:  $\varnothing$ 260x(H)200 mm.
- Maximum dough load of 8 kg.
- Weight: 42 kg.

code	V	W	mm
226315	35 kg/h	230	370 260x500x(H)500

### SPIRAL MIXER WITH FIXED BOWL - 22 L

- Model with fixed head and bowl.
- Bowl capacity: 20 liter.
- Bowl dimensions:  $\varnothing$ 360x(H)210 mm.
- Maximum dough load of 17 kg.
- Weight 56 kg.

code	V	W	mm
226209	56 kg/h	400	750 385x670x(H)725

### SPIRAL MIXER WITH FIXED BOWL - 32 L

- Model with fixed head and bowl.
- Bowl capacity: 32 litres.
- Bowl dimensions:  $\varnothing$ 400x(H)260 mm.
- Maximum dough load of 25 kg.
- Weight 90 kg.

code	V	W	mm
226308	88 kg/h	400	1100 424x735x(H)805



Liftable head makes it easy to remove the bowl

With integrated timer

226346

Bowl is made from 18/10 stainless steel

**NEW!**

**SPIRAL MIXER WITH REMOVABLE BOWL - 10 L**

- Model with liftable head and removable bowl.
- Bowl capacity: 10 litres.
- Bowl dimensions: ø260x(H)200 mm.
- Maximum dough load of 8 kg.
- Weight 60 kg.

code	V	W	mm
226339	35 kg/h	230	370 385x670x(H)675

**SPIRAL MIXER WITH REMOVABLE BOWL - 20 L**

- Model with liftable head and removable bowl.
- Bowl capacity: 20 litres.
- Bowl dimensions: ø360x(H)210 mm.
- Maximum dough load of 17 kg.
- Weight 73 kg.

code	V	W	mm
226346	56 kg/h	400	750 385x670x(H)725

**SPIRAL MIXER WITH REMOVABLE BOWL - 32 L**

- Model with liftable head and removable bowl.
- Bowl capacity: 32 litres.
- Bowl dimensions: ø400x(H)210 mm.
- Maximum dough load of 25 kg.
- Weight 94,6 kg.

code	V	W	mm
226353	88 kg/h	400	100 424x735x(H)805





See movie



224847

**S.S.**  
stainless steel
**PASTA MAKER ELECTRIC**

- Perfect for making fresh pasta (max. width: 170 mm).
- Cover equipped with safety switch.
- Dough thickness adjustable in 7 steps from 0,2 to 2,5 mm.
- Three rollers/cutters: dough roller, tagliatelle cutter (6,25 mm) and fettuccine cutter (2 mm).

code	V	W	mm
224847	230	70	258x218x(H)232



224830

**S.S.**  
stainless steel  
wash
**PASTA MAKER**

- Perfect for making fresh pasta (max. width: 140 mm).
- Dough thickness adjustable in 7 steps from 0,2 to 2,5 mm.
- Three aluminium alloy rollers/cutters: dough roller, tagliatelle cutter and fettuccine cutter.
- Includes a hand crank and a clamp for table mounting.

code	mm
224830	440x382x(H)340





## ELECTRIC DOUGH ROLLERS



see movie



Perfect for pizza and pasta dough

226629

### ELECTRIC DOUGH ROLLER 300

- Perfect for rolling cold pizza dough, pasta dough and dumpling/ravioli dough.
- Two sets of adjustable rollers shape the dough into a disc of consistent thickness.
- Separate roller guards ensure easy and safe operation.
- Weight 25 kg.
- Rolled dough disc diameter: 14 to 30 cm.

code	weight (kg)	V	W	mm
226629	0,08-0,21	230	250	440x365x(H)640



226636

### ELECTRIC DOUGH ROLLER 400

- Perfect for rolling cold pizza dough, pasta dough and dumpling/ravioli dough.
- Two sets of adjustable rollers shape the dough into a disc of consistent thickness.
- Separate roller guards ensure easy and safe operation.
- Patented model, switches on automatically when you enter the dough.
- Weight 37 kg.
- Rolled dough disc diameter: 26 to 40 cm.

code	weight (kg)	V	W	mm
226636	0,21-0,70	230	370	550x365x(H)750



226612

### ELECTRIC DOUGH ROLLER 500

- Perfect for rolling cold pizza dough and pasta dough.
- One set of rollers, electric foot pedal.
- Adjustable dough thickness, diameter adjustable from 26 to 50 cm.
- Roller guard.
- Weight 27 kg.

code	weight (kg)	V	W	mm
226612	0,21-0,70	230	370	645x360x(H)430

With electric foot pedal





880968

880906

**NEW!**

**LID FOR PIZZA DOUGH BOXES**



code	mm
880968	600x400

**PIZZA DOUGH BOX**



code	liter	mm int.	mm
880906	14	565x365x(H)70	600x400x(H)75
880913	18	565x365x(H)90	600x400x(H)95
880920	24	565x365x(H)120	600x400x(H)130



617014



617700



617014



617700

**PIZZA SLICER**

- Stainless steel knife blade.
- Polypropylene handle.



code	mm
617014	ø100x230

**PAN GRIPPER**

- Stainless steel.
- Suitable for all types of pizza pans.

code	Dimensions (mm)
617700	190 mm



523902

523957

**CAKE SERVER**

- With black polypropylene handle

code	mm
523902	260x60

**CAKE SCOOP/CUTTER**

- With black polypropylene handle
- With cutting sides

code	mm
523957	295x75

## PIZZA PAN

- Made of blue steel.
- Ideal for uniform heat distribution when baking.



code	mm
617069	ø200x(H)25
617076	ø220x(H)25
617083	ø240x(H)25
617090	ø260x(H)25
617106	ø280x(H)25
617205	ø300x(H)25
617304	ø320x(H)25
617403	ø360x(H)25
617410	ø400x(H)25
617427	ø450x(H)38
617434	ø500x(H)38



617069

## PIZZA SCREEN

- Solid construction
- Ideal for uniform pizza baking



code	mm
617502	Ø230
617526	Ø280
617533	Ø300
617540	Ø330
617557	Ø360
617564	Ø400
617571	Ø450
617588	Ø500
617595	Ø600



617502

## PIZZA BOARDS

- Made of raw beech wood.
- With grooves to assist cutting into 6 equal parts.

code	mm
505540	ø300
505557	ø350
505564	ø400
505571	ø450
505588	ø500
505595	ø600



505540



ø500 and 600 mm have a reinforced bottom

## PIZZA OVEN

- Tray grid suitable for pizzas up to ø 30 cm.
- Timer adjustable up to 15 minutes.
- With top and bottom heating elements and crumbs tray.
- Suitable for frozen pizzas.

code	V	W	mm
220306	230	1300	480x420x(H)195



220306



## PIZZA ACCESSORIES



### PIZZA SCOOP

- Wooden handle

code	mm
617816	305x355x(L)965
617861	405x457x(L)860

### PIZZA OVEN CLEANING BRUSH

- Brush made of brass wire  
- Removable wooden handle ended with a screw  
- Steel scraper

code	mm
525630	255x(L)930

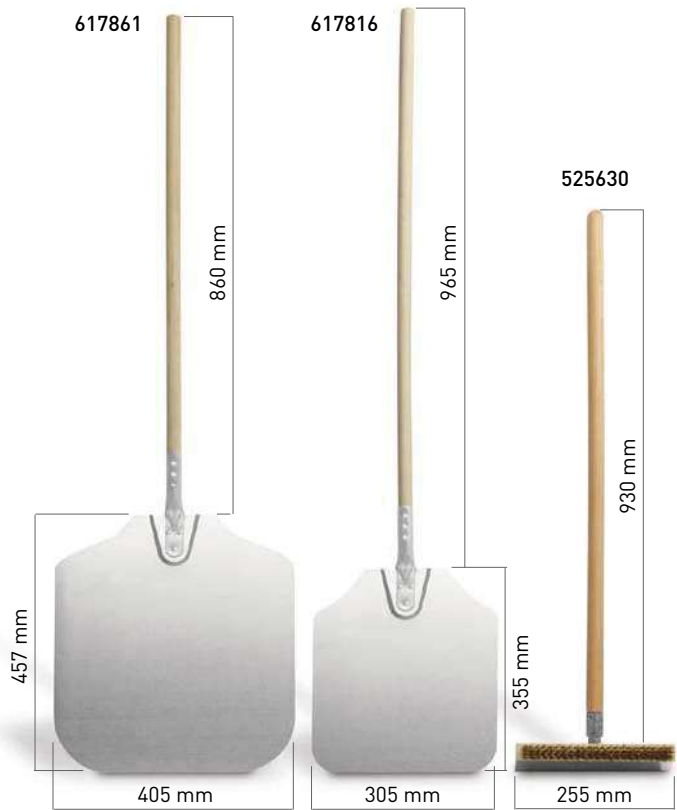

### PIZZA DELIVERY BAGS

- Thermal insulation delivery bags save time and money and help improve the quality of your services  
- The product remains hot and tasty all the way to the customer



709825



709818

### PIZZA DELIVERY BAG - BOX 350X350 MM

- Tight shutter easy to regulate.  
- Made of tough and easy to clean material.  
- Side pockets for drinks.  
- Top transparent pocket for bills.

code		Dimensions (mm)
709825	4 boxes	350x350

### PIZZA DELIVERY BAG - BOX 450X450 MM

- Tight shutter easy to adjust.  
- Made of tough and easy to clean material.  
- Side pockets for drinks.  
- Top transparent pocket for bills.

code		Dimensions (mm)
709818	4 boxes	450x450



709900

### LID SPACER FOR PIZZA'S

- Height of the lid spacer: 35 mm



code	packed per
709900	500







226865

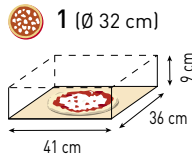

**PIZZA OVEN BASIC 1/40**

- Stainless steel front panel and painted steel body.
- With internal lighting.
- Refractory bricks in the cooking chamber.
- Heating elements in the chamber (top and bottom).
- Separate thermostat for each heating element.
- Temperature range: 50°C to 320°C.
- Inside dimensions of the chamber: 410x360x(H)90 mm.

code	V	W	mm
226865	230	1600	568x430x(H)280



226872

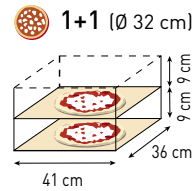

**PIZZA OVEN BASIC 2/40**

- Stainless steel front panel and painted steel body.
- Insulation made of rock wool.
- Refractory bricks in the cooking chamber.
- Heating elements in the chamber (top and bottom).
- Separate thermostat for each heating element.
- Temperature range: 50°C to 320°C.
- Inside dimensions of the chamber: 410x360x(H)90 mm.

code	V	W	mm
226872	230	2400	568x430x(H)425



226889

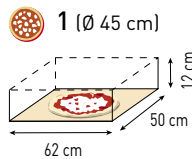

**PIZZA OVEN BASIC 1/50 VETRO**

- Stainless steel front panel and painted steel body.
- Insulation made of rock wool.
- Refractory bricks in the cooking chamber.
- Heating elements in the chamber (top and bottom).
- Separate thermostat for each heating element.
- Temperature range: 50°C to 500°C.
- Inside dimensions of the chamber: 620x500x(H)120 mm.

code	V	W	mm
226889	230/400	5000	915x621x(H)357



226896

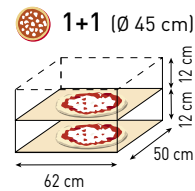

**PIZZA OVEN BASIC 2/50 VETRO**

- Stainless steel front panel and painted steel body.
- Insulation made of rock wool.
- Refractory bricks in the cooking chamber.
- Heating elements in the chamber (top and bottom).
- Separate thermostat for each heating element.
- Temperature range: 50°C to 500°C.
- Inside dimensions of the chamber: 620x500x(H)120 mm.

code	V	W	mm
226896	230/400	7500	915x621x(H)527



227060

Two highly efficient fans, distributing hot air evenly



#### CONVECTION OVEN H90

- Stainless steel body, door with double glazing.
- Cool touch door which can be removed to ease cleaning.
- Inside is partially enamelled and has interior lighting.
- Heating by means of two heating elements and two fans.
- Temperature adjustable from 50°C to 300°C.
- Timer adjustable from 0 to 120 minutes.
- Oven fits 4 trays, distance between the trays is 70 mm.
- Supplied with 4 trays (436x315 mm).

code	V	W	mm
227060	230	2670	595x595x(H)570
801970	grid		433x338
943380	tray		435x315x(H)8

Fits four aluminium trays



Double, heat resistant glass



Fitted with interior lighting





227077

Direct humidification

### HUMIDIFIED CONVECTION OVEN H90S

- Stainless steel body, door with double glazing.
- Cool touch door which can be removed to ease cleaning.
- Inside is partially enamelled and has interior lighting.
- Heating by means of two heating elements and two fans.
- Temperature adjustable from 50°C to 300°C.
- Direct humidification, manually operated with a button.
- Timer adjustable from 0 to 120 minutes.
- Oven fits 4 trays, distance between the trays is 70 mm.
- Supplied with 4 trays (438x315 mm).

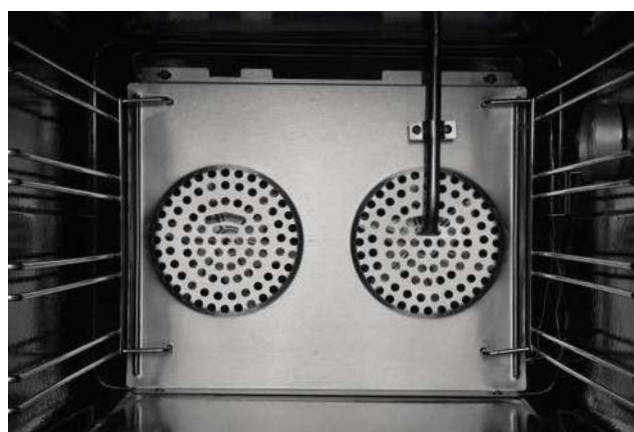

code	V	W	mm
227077	230	2670	595x595x(H)570
801970	grid		433x338
943380	tray		435x315x(H)8

Removable door eases cleaning



Glass stays cool enough to touch



With clamp to remove hot trays



**NEW!**



**CONVECTION STEAM OVEN WITH GRILL 4X GN 2/3**

- High-quality stainless-steel body and chamber.
- Manual control panel with knobs for function, temperature, time and amount of steam.
- Has functions for defrost, pre-heat, convection, grill, steam or a combination of those functions.
- Temperature can be set up to 280°C
- Timer can be set up to 120 minutes.
- Convection by means of two heating elements and one fan
- With top grill elements.
- Oven fits 4 GN2/3 trays, distance between the trays is 70 mm.
- Supplied with 1 grid GN2/3.
- Convection 3 kW, grill: 1.8 kW.
- Chamber heaters: bottom 1.6 kW, top 0.7 kW.
- Adjustable feet from 55 to 75 mm.

code	V	W	mm
225929	230	3000	620x555x(H)585
224823	Stand for oven 225929		580x390x(H)750

CONVECTION OVENS

**CONVECTION SNACK OVENS**

- Ideal solution for businesses wishing to add fresh and tasty baked goods to their product range.
- Compact size and cost-effective energy consumption make it fit for installation practically anywhere.
- Built-in humidifier makes the oven suitable for even the most

- sophisticated baked goods.
- Body and cooking chamber made of stainless steel.
- Glass door with gravity ventilation.
- Cooling system for controls.



225165

**CONVECTION OVEN MULTIFUNCTIONAL**

- Fits 4 trays 429 x 345 mm, 4 trays included.
- One non-reversible fan.
- Body and chamber made of stainless steel.
- Double layer glass door, cools front pane by means of natural convection.
- Tray support spacing 74 mm.
- Temperature range: 50 to 230°C.

code	weight (kg)	V	W	mm
225165	36,4	230	2600	590x695x(H)590



224670



**FLOOR STAND FOR SNACK OVENS**

- Capacity: 6x 429x345 mm.
- Compatible with Hendi oven 225165.

code	mm
224670	540x460x(H)700



## CONVECTION BAKERY OVENS - 600X400 MM

- Ideal solution for businesses wishing to add fresh and tasty baked goods to their product range.
- Compact size and cost-effective energy consumption make it fit for installation practically anywhere.
- Built-in humidifier makes the oven suitable for even the most

- sophisticated baked goods.
- Body and cooking chamber made of stainless steel.
- Glass door with gravity ventilation.
- Cooling system for controls.

18/0  
stainless steel

## BAKERY HUMIDIFIED CONVECTION OVEN

- Two non-reversible fans.
- Indirect humidification, manually operated with a button.
- Fits up to four 600 x 400 mm trays, not included.
- Body and chamber made of stainless steel.
- Double layer glass door, cools front pane by means of natural convection.
- Tray support spacing 83 mm.
- Temperature range: 50 to 230°C.

code	weight (kg)	V	W	mm
225516	50,4	230	3400	790x750x(H)635



225516

## STEAM CONVECTION OVEN

- Two reversible fans.
- Direct humidification, adjustable in 5 steps.
- Fits up to four 600 x 400 mm trays, not included.
- Chamber made of stainless steel 18/10.
- Double layer glass door, cools front pane by means of natural convection.
- Tray support spacing 83 mm.
- Temperature range: 50 to 230°C.

code	weight (kg)	V	W	mm
225523	58	400 / 2N	6400	790x750x(H)635



225523

## FLOOR STAND FOR BAKERY OVENS

- Capacity: 6x 600x400.
- Suitable for ovens: 225516, 225523.

code	mm
225639	760x520x(H)950



225639



## CONVECTION OVENS & COMBI-OVENS NANO 4X 450X340MM

- These ovens are the way to go when you want to create scrumptious baked goods, vegetables with a bite, flavourful roasted meats and poultry or perfectly steamed fish.
- Housing and chamber are made of high-quality stainless steel, the chamber is equipped with a drain in the bottom.
- The powerful 6 bladed fan can spin at two speeds (1400/2800 rpm), this results in ideal distribution of air in chamber and preventing inner turbulence. The fan motor has double bearings and 250W of power.
- Timer can be set up to 120 minutes, temperature up to 260°C.
- The door is fitted with two layers of glass with space for gravity ventilation, this keeps the outside glass cool to the touch. Outside glass can be removed to ease cleaning.

# NANO

## NEW!

- Door gasket is fitted in the chamber and removable to ease cleaning and replacement.
- Chamber capacity of 4 trays (450x340mm), tray guides are placed 75 mm apart.
- Comes complete with 4 aluminium trays (450x340mm).



223369

### MULTI-FUNCTIONAL CONVECTION OVEN MANUAL WITH HUMIDIFIER NANO

- Manual control panel, three knobs for temperature, time and mode.
- With a humidifier button for indirect humidification.
- 4 modes: defrosting, convection, grill and grill with convection.
- Equipped with 1 non-reversible fan.
- Weight: 36 kg.

code	V	W	mm
223369	230	3100	560x595x(H)530



223376

### CONVECTION OVEN MANUAL NANO

- Manual control panel, two knobs for temperature and time.
- Equipped with 1 non-reversible fan.
- Weight: 36 kg.

code	V	W	mm
223376	230	2850	560x595x(H)530



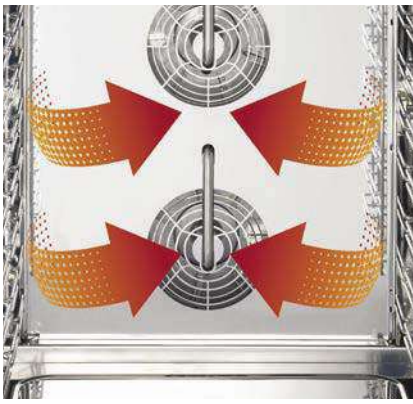

### CONVECTION OVEN MANUAL WITH HUMIDIFIER NANO

- Manual control panel, two knobs for temperature and time.
- With a humidifier button for indirect humidification.
- Equipped with 1 reversible fan.
- Weight: 38 kg.

code	V	W	mm
223352	230	3200	560x595x(H)530



223352

### CONVECTION OVEN DIGITAL WITH HUMIDIFIER NANO

- Digital control panel, easy control over the time, temperature and humidification.
- The oven is programmable, possibility to create 99 3-step programs, 4 if pre-heating is added to the program.
- Equipped with 1 reversible fan.
- Weight: 38 kg.

code	V	W	mm
223345	230	3100	560x595x(H)530



223345

### STAND FOR OVENS NANO 4X 450X340MM

- For ovens 223376, 223369, 223352, 223345.

code	mm
223031	560x510x800



223031



## CONVECTION STEAM OVENS DIGITAL NANO GN-SIZE

- A convection steam oven combines the efficiency of a convection oven with the capabilities of a steam oven. These modes can be used separately or in conjunction with one another. These ovens are the way to go when you want to create scrumptious baked goods, vegetables with a bite, flavorful roasted meat and poultry or perfectly steamed fish.
- Steam is generated by directly spraying water on the heaters. The steam levels in the chamber are controllable and the oven has multiple automated features to maintain the set levels. Works with a direct water connection: 3/4", max 30°C, 150-200 kPa (2 bar), only treated, softened water.
- Housing and chamber are made of high-quality stainless steel, the chamber is equipped with a drain in the bottom.
- The powerful 6 bladed fan(s) have auto-reverse and can spin at two speeds (1400/2800 rpm), this results in ideal distribution of air in chamber and preventing inner turbulence. The fan motor has double bearings and 250W of power.
- The digital control panel has clear readouts for the different functions, time, temperature and cooking program.

# NANO

## NEW!

- Electronic timer can be set up to 999 minutes, temperature up to 260°C.
- The oven is programmable to ensures the same level of quality in day to day operations. It's possible to create 99 3-step programs, 4 if pre-heating is also added to the program.
- The oven is fitted with a removable temperature probe which can work in conjunction with the incorporated Delta-T cooking function.
- Keeps the chamber warm before pre-heating to ensure quick ready times.
- The door is fitted with two layers of glass with space for gravity ventilation, this keeps the outside glass cool to the touch. Outside glass can be removed to ease cleaning.
- Door gasket is fitted in the chamber and removable to ease cleaning and replacement.
- The chamber is fitted removable GN-tray guides and halogen lighting.
- Automatic chamber heating before "PRE-HEATING" cycle.



223291

### CONVECTION STEAM OVEN DIGITAL NANO 5X GN2/3

- Capacity of 5x GN2/3, GN-tray guides are placed 67 mm apart.
- With 1 reversible fan.
- Weight: 64 kg.

code		V	W	mm
223291	5x GN2/3	400	5400	700x714x(H)628
223666	stand for 5x GN2/3 ovens			700x580x(H)700



223123

### CONVECTION STEAM OVEN DIGITAL NANO 5X GN1/1

- Capacity of 5x GN1/1, GN-tray guides are placed 67 mm apart.
- With 2 reversible fans.
- Weight: 103 kg.

code		V	W	mm
223123	5x GN1/1	400	13800	920x834x(H)699
223659	stand for 5x GN1/1 ovens			940x640x(H)700







### CONVECTION STEAM OVEN DIGITAL NANO 7X GN1/1

- Capacity of 7x GN1/1, GN-tray guides are placed 67 mm apart.
- With 2 reversible fans.
- Weight: 117 kg.

code		V	W	mm
223109	7x GN1/1	400	13800	920x834x(H)859
223659	stand for 7x GN1/1 ovens			940x640x(H)700



223109

### CONVECTION STEAM OVEN DIGITAL NANO 12X GN1/1

- Capacity of 12x GN1/1, GN-tray guides are placed 67 mm apart.
- With 3 reversible fans.
- Weight: 151 kg.

code		V	W	mm
223086	12x GN1/1	400	13800	920x834x(H)1195
223642	stand for 12x GN1/1 ovens			940x640x(H)500



223086

### CONVECTION STEAM OVEN DIGITAL NANO 20X GN1/1

- Capacity of 20x GN1/1, GN-tray guides are placed 67 mm apart.
- With 4 reversible fans.
- Weight: 250 kg.

code		V	W	mm
223215	20x GN1/1	400	28000	1050x940x(H)1900



223215



## CONVECTION STEAM OVENS MANUAL NANO GN-SIZE

- A convection steam oven combines the efficiency of a convection oven with the capabilities of a steam oven. These modes can be used separately or in conjunction with one another. These ovens are the way to go when you want to create scrumptious baked goods, vegetables with a bite, flavourful roasted meat and poultry or perfectly steamed fish.
- Steam is generated by directly spraying water on the heaters. The steam levels in the chamber are controllable and the oven has multiple automated features to maintain the set levels. A direct water connection is needed: 3/4", max 30°C, 150-200 kPa (2 bar), only treated, softened water.
- Housing and chamber are made of high-quality stainless steel, the chamber is equipped with a drain in the bottom.
- The powerful 6 bladed fan(s) have auto-reverse and can spin at two speeds (1400/2800 rpm), this results in ideal distribution of air in chamber and preventing inner

# NANO

## NEW!

- turbulence. The fan motor has double bearings and 250W of power.
- The manual control panel has thermostat and steaming indicator lights and three large knobs for setting the time, temperature and amount of steam.
- Timer can be set up to 120 minutes, temperature up to 260°C.
- The door is fitted with two layers of glass with space for gravity ventilation, this keeps the outside glass cool to the touch. Outside glass can be removed to ease cleaning.
- Door gasket is fitted in the chamber and removable to ease cleaning and replacement.
- The chamber is fitted removable GN-tray guides and halogen lighting.



223307

### CONVECTION STEAM OVEN MANUAL NANO 5X GN2/3

- Capacity of 5x GN2/3, GN-tray guides are placed 67 mm apart.
- With 1 reversible fan.
- Weight: 64 kg.

code		V	W	mm
223307	5x GN2/3	400	5400	700x714x(H)628
223666	stand for 5x GN2/3			700x580x(H)700



223130

### CONVECTION STEAM OVEN MANUAL NANO 5X GN1/1

- Capacity of 5x GN1/1, GN-tray guides are placed 67 mm apart.
- With 2 reversible fans.
- Weight: 103 kg.

code		V	W	mm
223130	5x GN1/1	400	13800	920x834x(H)699
223659	stand for 5x GN1/1 ovens			940x640x(H)700

Removable door gasket



Direct water injection





### CONVECTION STEAM OVEN MANUAL NANO 7X GN1/1

- Capacity of 7x GN1/1, GN-tray guides are placed 67 mm apart.
- With 2 reversible fans.
- Weight: 117 kg.

code		V	W	mm
223116	7x GN1/1	400	13800	920x834x(H)859
223659	stand for 7x GN1/1 ovens			940x640x(H)700



223116

### CONVECTION STEAM OVEN MANUAL NANO 12X GN1/1

- Capacity of 12x GN1/1, GN-tray guides are placed 67 mm apart.
- With 3 reversible fans.
- Weight: 151 kg.

code		V	W	mm
223093	12x GN1/1	400	13800	920x834x(H)1195
223642	stand for 12x GN1/1 ovens			940x640x(H)500



223093

### CONVECTION STEAM OVEN MANUAL NANO 20X GN1/1

- Capacity of 20x GN1/1, GN-tray guides are placed 67 mm apart.
- With 4 reversible fans.
- Weight: 250 kg.

code		V	W	mm
223222	20x GN1/1	400	28000	1050x940x(H)1900



223222





808207

**TRAY**  
- With 3 rims



code	mm
808207	600x400



808214

**TRAY PERFORATED**  
- With 3 rims



code	mm
808214	600x400



808221

**TRAY PERFORATED - WITH 3 RIMS**  
- With Teflon™ non-stick coating.  
- With 3 rims.



code		mm
808221	Non-stick coating	600x400



808245

**TRAY FOR FRENCH BREAD**  
- With Teflon™ non-stick coating.  
- Perforated.  
- Fits 5 loaves of french bread.



code		mm
808245	Non-stick coating	600x400



808238

**TRAY FOR FRENCH BREAD**  
- Perforated  
- Fits 5 loaves of french bread



code	mm
808238	600x400



801925

**GRID**



code	mm
801994	600x400
801925	Grid transverse
801963	Chrome plated





808306



**TRAY PERFORATED GN 1/1 - WITH 4 RIMS**

code	mm
808306	530x325x(H)10



808405

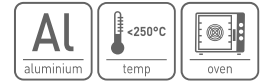

**TRAY PERFORATED GN 1/1 - WITH 4 RIMS**  
- With Teflon™ non-stick coating.

code	mm
808405	530x325x(H)10



808429

**TRAY GN 1/1 - WITH 4 RIMS**  
- With Teflon™ non-stick coating.

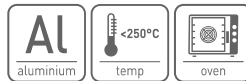

code	mm
808429	325x530x(H)10

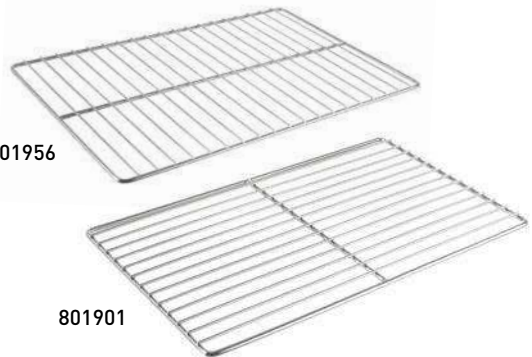

801956

801901

**GASTRONORM GRID**  
- GN 1/1



code	mm
801901	530x325
801918	Stainless steel 18/10
801956	Chrome plated - transverse grid



809242

809259

809150

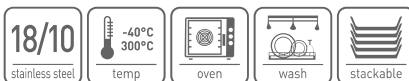

**GASTRONORM TRAY PROFI LINE**

code	mm
809242	GN 1/1 - 530x325x(H)40
809259	GN 1/1 - 530x325x(H)20
809150	GN 2/1 - 650x530x(H)20

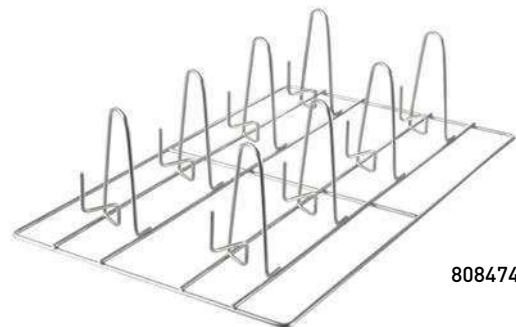

808474

**CHICKEN GRID**  
- For roasting 8 chickens



code	mm
808474	GN 1/1 530x325x(H)150,8





890257

890240

890233

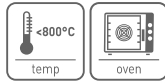

**GASTRONORM CONTAINER ENAMELLED**

code	mm
890233	530x325x(H)60
890240	530x325x(H)40
890257	530x325x(H)20



805558

805541

805534



**CONTAINER WITH NON-STICK COATING**

code	mm
805534	530x325x(H)65
805541	530x325x(H)40
805558	530x325x(H)20



808313



**TRAY PERFORATED GN 2/3 - WITH 4 RIMS**

code	mm
808313	354x325x(H)10



808412



**TRAY PERFORATED GN 2/3 - WITH 4 RIMS**

- With Teflon™ non-stick coating.

code	mm
808412	354x325x(H)10



801932



**GASTRONORM GRID GN 2/3**

code	mm
801932	354x325

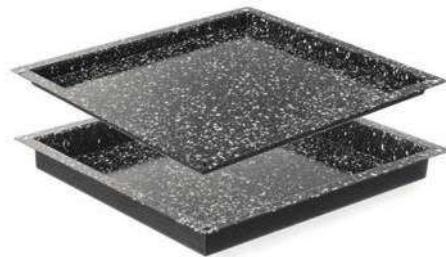

890356

890349

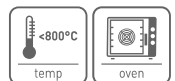

**GASTRONORM CONTAINER ENAMELLED GN 2/3**

code	mm
890349	345x325x(H)40
890356	345x325x(H)20

## OVEN MITTS

- Certified protective gloves. CE compliant in accordance with the Personal Protective Equipment Directive 89/686/EEC.



### OVEN MITTS, COTTON

code	packed per	mm
556603	2	345



### OVEN MITTS, FIBERGLASS

code	packed per	mm
556627	2	430



### OVEN MITTS, FLAME RETARDANT COTTON

- Extra long to protect the forearm

code	packed per	mm
556610	cotton with flame retardant coating	430



### OVEN GLOVE HEAT RESISTANT

- Heat resistant up to  $350^{\circ}\text{C}$ .  
- Comfortable fit.

code	packed per	mm
556634	2	300



**NEW!**



### OVEN MITTS LEATHER

- Made from cow leather.  
- Extra long to protect the forearm.

code	packed per	mm
556658	2	460



# NEW!



233825

### ROUND CAKE DISPLAY 100L

- Housing made of stainless steel fitted with tempered double glazing.
- Accessible through self-closing door.
- Forced air cooling with auto-defrost, compressor placed underneath the chamber.
- Fitted with 3 adjustable glass shelves.
- Bright LED lighting on 2 sides.
- Digital temperature controller and display, with on/off switch.
- Temperature range: 2°/8°C.
- Climate class: N
- Refrigerant: R600a.

code	liter	V	W	mm
233825	100	230	210	ø480x(H)1030



233832

### ROUND CAKE DISPLAY 360L

- Housing made of stainless steel fitted with tempered double glazing.
- Accessible through self-closing door.
- Forced air cooling with auto-defrost, compressor placed underneath the chamber.
- Fitted with 4 adjustable glass shelves.
- Bright LED lighting on 2 sides.
- Fitted with 3 castors of which 1 has a brake.
- Digital temperature controller and display, with on/off switch.
- Temperature range: 2°/8°C.
- Climate class: N
- Refrigerant: R290.

code	liter	V	W	mm
233832	360	230	460	ø680x(H)1750

COOLING



233207

### CAKE DISPLAY 110L

- Housing made of stainless steel fitted with, curved double glazed front cover and glass side panels.
- Accessible through two sliding glass doors.
- 20 mm thick expanded polystyrene foam insulation.
- Forced air cooling with auto-defrost, compressor placed underneath the chamber.
- 2 chrome plated shelves (630x230mm and 630x280mm) included. Max. capacity of 5 kg each.
- Bright LED lighting in the ceiling.
- Digital temperature controller and display.
- Temperature range: 2/8°C.
- Climate class: 3
- Refrigerant: R290.

code	liter	V	W	mm
233207	110	230	220	700x557x(H)670



233214

### CAKE DISPLAY 130L

- Housing made of stainless steel fitted with, curved double glazed front cover and glass side panels.
- Accessible through two sliding glass doors at the back.
- 20 mm thick expanded polystyrene foam insulation.
- Forced air cooling with auto-defrost, compressor placed underneath the chamber.
- 2 chrome plated shelves (830x230mm and 830x280mm) included. Max. capacity of 6,5 kg each.
- Bright LED lighting in the ceiling.
- Digital temperature controller and display.
- Temperature range: 2°/8°C.
- Climate class: 3
- Refrigerant: R290.

code	liter	V	W	mm
233214	130	230	260	900x557x(H)670





233702



233719



See movie



**CAKE DISPLAYS**

- Housing made of stainless steel fitted with, curved glass front cover and glass side panels.
- Accessible through two sliding glass doors at the back.
- Forced air cooling with auto-defrost, compressor placed underneath the chamber.
- 2 chrome plated shelves included.
- Bright LED lighting in the ceiling.
- Digital temperature controller and display.
- Temperature range: 0°/12°C.
- Climate class: N
- Refrigerant: R290.

code	liter	V	W	mm
233702	120	230	160	686x568x(H)686
233719	160	230	160	850x568x(H)686



Forced air cooling

Digital display



Glass side panels

Sliding doors

**NEW!**

**OPEN FRONT MULTIDECK DISPLAY REFRIGERATOR 320L**



- Housing made of stainless steels fitted with hardened safety glass.
- Forced air cooling with auto-defrost, compressor placed underneath the chamber.
- Fitted with three shelves.
- Fitted with easy to remove lockable sliding doors.
- With LED lighting at the top and under each shelf.
- Fitted with 4 castors of which 2 have brakes.
- Digital temperature controller and display.
- Max. ambient temperature: 28°C.
- Refrigerant: R290.

code	range	V	W	mm
233252	-1°/10°C	230	1300	920x847x(H)1465



233252



REFRIGERATED DISPLAY CABINETS WITH BACK ACCESS



**NEW!**



233306

- Housing made of stainless steel fitted with double glazing.
- Accessible through two sliding doors at the back.
- Forced air cooling with auto-defrost, compressor placed underneath the chamber.
- With bright LED lighting at the top and under each shelf.
- Fitted with 4 castors of which 2 have brakes.
- Digital temperature controller and display.
- Temperature range: 2°/8°C.
- Climate class: N
- Refrigerant: R290.

**REFRIGERATED DISPLAY CABINETS WITH 3 SLANTED SHELVES**

- Fitted with 3 adjustable slightly slanted glass shelves.

code	liter	V	W	mm
233306	300	230	480	650x805x(H)1445
233443	500	230	490	900x805x(H)1445
233320	650	230	490	1200x805x(H)1445

COOLING



233337

**REFRIGERATED DISPLAY CABINETS WITH 2 SHELVES**

- Fitted with 2 adjustable glass shelves.

code	liter	V	W	mm
233337	300	230	480	915x675x(H)1210
233450	410	230	490	1215x675x(H)1210
233375	510	230	490	1515x675x(H)1210
233467	610	230	500	1815x675x(H)1210



233276

**REFRIGERATED DISPLAY CABINETS**

- Housing made of stainless steel fitted with triple glazing.
- With self-closing door.
- Forced air cooling with auto-defrost, compressor placed underneath the chamber.
- Fitted with 3 adjustable chrome plated shelves.
- Bright LED lighting in the 4 posts.
- Fitted with 4 castors of which 2 have brakes.
- Digital temperature controller and display, with on/off switch.
- Temperature range: 2°/8°C.
- Climate class: N
- Refrigerant: R290.

code	liter	V	W	mm
233276	400	230	495	650x650x(H)1908
233283	550	230	495	850x850x(H)1908



Possibility to place an graphic image

233757

**SUSHI DISPLAY GN 1/3 63L**

- White coated stainless steel housing, fitted with double glazing and curved glass cover.
- Accessible through two sliding doors at the back or via the curved glass cover.
- Forced air cooling with auto-defrost, compressor placed next to the chamber.
- Fits 5x GN 1/3 trays.
- Fitted with LED lighting and evaporator at the top.
- Digital temperature controller and display.
- Refrigerant: R600a.
- Climate class: 3

code	range	V	W	mm
233757	0°/12°C	230	160	1307x450x(H)330



**COUNTERTOP FREEZER DISPLAY 77L**

- Body made of high-quality stainless steel, fitted with triple glazed cover with easy opening system.
- Forced air cooling with auto-defrost, compressor placed next to the chamber.
- Fits 8x GN 1/6 GN containers or 4x GN 1/4 containers (max. height 150 mm).
- With 4 adjustable stainless steel feet.
- Digital temperature controller and display.
- Refrigerant: R600a.
- Climate class: 4

code	range	V	W	mm
233689	-25°/-18°C	230	162	805x666x(H)305



233689



**COUNTERTOP SALAD DISPLAY 67L**

- Body made of high-quality stainless steel, fitted with curved glass cover with easy opening system.
- Forced air cooling with auto-defrost, compressor placed next to the chamber.
- Fits 8x GN 1/6 GN containers or 4x GN 1/4 containers (max. height 150 mm).
- With 4 adjustable stainless steel feet.
- Digital temperature controller and display.
- Refrigerant: R600a.
- Climate class: 4

code	range	V	W	mm
233672	0°/12°C	230	105	767x612x(H)328



See movie



233672





## REFRIGERATED DISPLAY CABINETS

- Housing made of coated stainless steel fitted with double glazing.
- With self-closing door.
- Forced air cooling with auto-defrost, compressor placed underneath the chamber.
- Air duct outside of the glass blows air over the glass to remove and prevent condensation.

- Durable PVC coated shelves, adjustable in height.
- With bright LED lighting in the ceiling.
- Digital temperature controller and display.
- Temperature range: 0/12°C.
- Climate class: N
- Refrigerant: R600A.



233610



233627



233634

### REFRIGERATED DISPLAY CABINET 58L

- 2 shelves.

code	V	W	mm	
233610	white	230	170	452x406x(H)816
233627	black	230	170	452x406x(H)816

### REFRIGERATED DISPLAY CABINET 68L

- 3 shelves.

code	V	W	mm	
233634	white	230	170	452x406x(H)891
233238	black	230	170	452x406x(H)891 <b>NEW!</b>

COOLING

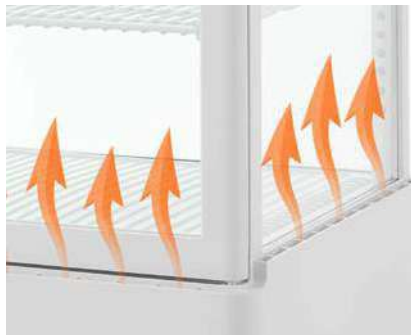

Air duct outside glass to remove and prevent condensation



Double glazing and easy opening door



Digital controller



Adjustable feet



Internal lighting in the ceiling



LED lights





See movie



233641



233658



233665

**REFRIGERATED DISPLAY CABINET 78L**

- 3 shelves.

code		V	W	mm
233641	white	230	170	452x406x(H)966
233658	black	230	170	452x406x(H)966

**REFRIGERATED DISPLAY CABINET 98L**

- 4 shelves.

code		V	W	mm
233665	white	230	190	452x406x(H)1116
233269	black	230	190	452x406x(H)1116 <b>NEW!</b>

**REFRIGERATED DISPLAY CABINET 280L**

- With 5 shelves and height adjustable feet.

code		V	W	mm
233696	white	230	290	556x526x(H)1913
233290	black	230	290	556x526x(H)1913 <b>NEW!</b>



4 wheels,  
2 with brakes



Double glazing and easy  
opening curved door



233696



## BACK BAR REFRIGERATORS

- Powder coated housing, embossed aluminium chamber, plastic lockable door(s) with toughened glass.
- Forced air cooling with auto-defrost, compressor placed underneath the chamber.

- Chamber fitted with LED lighting.
- Digital display and temperature control.
- Fitted with 4 adjustable non-slip feet.
- Coolant: R600a.

**NEW!**



233900

### BACK BAR REFRIGERATOR SINGLE DOOR 118L

- Single door, with 2 chrome plated shelves.

code	range	V	mm
233900	2°/10°C	230	500x500x(H)900



233917

### BACK BAR REFRIGERATOR SLIDING DOORS 228L

- Double sliding door, with 4 chrome plated shelves.

code	range	V	mm
233917	2°/10°C	230	900x500x(H)900



233924

### BACK BAR REFRIGERATOR SINGLE DOOR 293L

- Single door, with 5 chrome plated shelves.

code	range	V	mm
233924	2°/10°C	230	600x515x(H)1820



233931

### BACK BAR REFRIGERATOR DOUBLE DOORS 458L

- Double doors, with 10 chrome plated shelves.

code	range	V	mm
233931	2°/10°C	230	900x545x(H)1820



## WINE COOLERS DUAL ZONE

- Dual zone allows to set two different temperatures for the two zones.
- Black housing, borderless glass door fitted with stylish stainless steel handle.
- With lockable self-closing door.
- Forced air cooling with auto-defrost, compressor placed behind the chamber.
- Supplied with wooden shelves.
- With bright LED lighting in the ceiling.
- Digital temperature controller and display. Can be set in Celsius or Fahrenheit
- Fitted with 4 adjustable non-slip feet.
- Climate class: N
- Refrigerant: R600a.

**NEW!**

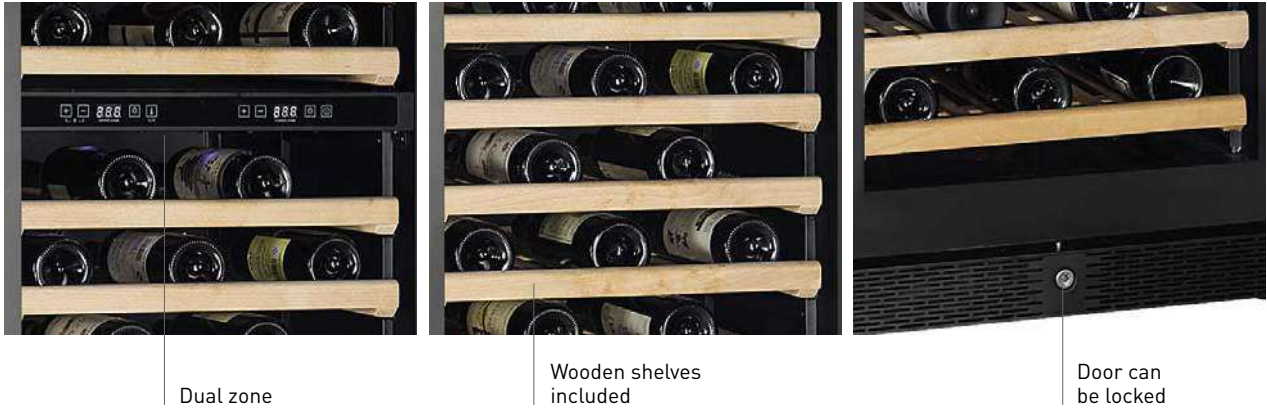

Dual zone

Wooden shelves included

Door can be locked



233221



233245

### WINE COOLER DUAL ZONE 165L

- Suitable for up to 44 bottles of wine.
- Supplied with 5 wooden shelves.

code	range	V	W	mm
233221	4°/20°C	230	130	596x654x(H)855

### WINE COOLER DUAL ZONE 450 L

- Suitable for up to 165 bottles of wine.
- Supplied with 15 wooden shelves.

code	range	V	W	mm
233245	4°/20°C	230	150	596x720x(H)1820





**NEW!**



**DISPLAY REFRIGERATORS WITH LIGHTBOX**

- Made of stainless steels, aluminium and polypropylene.
- Doors fitted with triple glazing of which one layer is tempered.
- Forced air cooling with auto-defrost, compressor placed underneath the chamber.
- Fitted with 8 adjustable PVC coated shelves.
- With LED lighting in the chamber and in the lightbox.
- Fitted with 4 castors of which 2 have brakes.
- Digital temperature controller and display.
- Climate class: N
- Refrigerant: R600a.



233788

**DISPLAY REFRIGERATOR SINGLE DOOR 360L**

- With a lockable door.

code	range	V	W	mm
233788	2°/10°C	230	220	620x669x(H)1965

COOLING



233795

**DISPLAY REFRIGERATOR DOUBLE DOOR 750L**

- With two lockable doors.

code	range	V	W	mm
233795	2°/10°C	230	240	1120x595x(H)1965



# NEW!

## COUNTERTOP DISPLAY FREEZER 90L

- Inner and outer housing made of high-quality plastic.
- Lockable door is fitted with triple glazing and heating element to prevent fogging up.
- Forced air cooling with auto defrost, compressor placed underneath the chamber.
- Fitted with 2 adjustable PVC coated shelves.
- With LED lighting at the top of the freezer.
- Digital temperature controller and display.
- Climate class: N
- Refrigerant: R290.

code	range	V	W	mm
233412	-22°/-18°C	230	160	620x575x(H)712



233412

# NEW!

## ICE CREAM DISPLAY FREEZER 600 L



- Housing made of stainless steel fitted with double glazing.
- Accessible through sliding doors at the back and an up hinged cover at the front.
- Forced air cooling with auto-defrost, compressor placed underneath the chamber.
- Possibility to fit up to 12 ice cream containers.
- With bright LED lighting at the top and on the sides.
- Fitted with 4 castors of which 2 have brakes.
- Digital temperature controller and display.
- Climate class: N
- Refrigerant: R404a.

code	range	V	W	mm
233849	-24°/-18°C	230	1050	1240x1065x(H)1410



233849

# NEW!



## CHEST FREEZER ENERGY EFFICIENT

- Housing made of aluminium.
- With self-closing lockable lid.
- Forced air cooling with manual-defrost, compressor placed underneath the chamber.
- 70 mm thick foam insulation.
- Bright LED lighting in the chamber.
- Digital temperature display and manual controller.
- Fitted with 2 wheels and 2 adjustable feet.
- Temperature range: -26/-18°C.
- Climate class: SN-T
- Refrigerant: R600a.

code	liter	V	W	mm
233856	190	230	85	953x607x(H)840
233863	282	230	90	1116x686x(H)840
233870	354	230	95	1275x785x(H)840
233887	445	230	100	1538x785x(H)840
233894	502	230	115	1655x785x(H)840



233856



**REFRIGERATORS & FREEZERS PROFI LINE | 700 SERIES**



- Inner and outer housing are made of high-quality stainless steel, except the outer rear cover which is made of galvanized steel.
- Self-closing lockable door(s) with comfortable curved door handle(s).
- Forced air cooling with auto-defrost, compressor placed above the chamber.

- 50 mm thick polyurethane foam insulation.
- With adjustable shelving, fits containers up to GN 1/1.
- Digital display and electronic thermostat.
- Fitted with 4 wheels of which 2 are castor wheels.
- Climate class: SN-ST.
- Coolant: R600a.

**NEW!**



233108  
233115

Chamber and outer housing made of stainless steel



233122  
233139

COOLING

**REFRIGERATOR SINGLE DOOR PROFI LINE 410 L**

- Chamber dimensions: 500x540x(H)1380 mm.
- 3 shelves (485x525mm) included. Spread load capacity of 40 kg each.
- Weight: 90 kg.

code	range	V	W	mm
233108	-2°/8°C	230	245	600x745x(H)1950

**REFRIGERATOR TWO DOORS PROFI LINE 900 L**

- Chamber dimensions: 1100x540x (H)1380 mm.
- 6 shelves (525x530mm) included. Spread load capacity of 40 kg each.
- Weight: 135 kg.

code	range	V	W	mm
233122	-2°/8°C	230	400	1200x745x(H)1950

**FREEZER SINGLE DOOR PROFI LINE 410L**

- Chamber dimensions: 500x540x(H)1380 mm.
- 3 shelves (485x525mm) included. Spread load capacity of 40 kg each.
- Weight: 90kg.

code	range	V	W	mm
233115	-17°/-22°C	230	450	600x745x(H)1950

**FREEZER TWO DOORS PROFI LINE 900L**

- Chamber dimensions: 1100x540x(H)1380 mm.
- 6 shelves (525x530mm) included. Spread load capacity of 40 kg each.
- Weight: 135 kg.

code	range	V	W	mm
233139	-17°/-22°C	230	750	1200x745x(H)1950

Electronic temperature controller

Shelves with spread load capacity of 40 kg

Self-closing, lockable door



## REFRIGERATORS & FREEZERS PROFI LINE | 800 SERIES



- Inner and outer housing are made of high-quality stainless steel, except the outer rear cover which is made of galvanized steel.
- Self-closing lockable door(s) with comfortable curved door handle(s).
- Forced air cooling with auto-defrost, compressor placed above the chamber.

- 60 mm thick polyurethane foam insulation.
- With adjustable shelving, fits containers up to GN 2/1.
- Digital display and electronic thermostat.
- Fitted with 4 wheels of which 2 are castor wheels.
- Climate class: SN-ST.
- Coolant: R600a.



232118  
232132

Chamber and outer housing made of stainless steel



232125  
232149

### REFRIGERATOR SINGLE DOOR PROFI LINE 670L

- Chamber dimensions: 610x635x(H)1540 mm.
- 3 shelves GN 2/1 (650x530mm) included. Spread load capacity of 40 kg each.
- Weight: 120 kg.

code	range	V	W	mm
232118	0°/8°C	230	220	730x805x(H)2065

### FREEZER SINGLE DOOR PROFI LINE 670L

- Chamber dimensions: 610x635x(H)1540 mm.
- 3 shelves GN 2/1 (650x530mm) included. Spread load capacity of 40 kg each.
- Weight: 120 kg.

code	range	V	W	mm
232132	-22°/-17°C	230	600	730x805x(H)2065

### REFRIGERATOR TWO DOORS PROFI LINE 1300 L

- Chamber dimensions: 1194x635x(H)1540 mm.
- 6 shelves GN 2/1 (650x530mm) included. Spread load capacity of 40 kg each.
- Weight: 171 kg.

code	range	V	W	mm
232125	0°/8°C	230	350	1314x805x(H)2065

### FREEZER TWO DOORS PROFI LINE 1300L

- Chamber dimensions: 1194x635x(H)1540 mm.
- 6 shelves GN 2/1 (650x530mm) included. Spread load capacity of 40 kg each.
- Weight: 177 kg.

code	range	V	W	mm
232149	-22°/-17°C	230	800	1314x805x(H)2065

Fitted with wheels



Dynamic forced cooling



Self-closing, lockable door



## REFRIGERATOR COUNTERS KITCHEN LINE | 700 SERIES

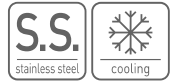

- Inner and outer housing are made of high-quality stainless steel.
- Doors fitted with comfortable handles.
- Forced air cooling with auto-defrost, compressor placed underneath the chamber.
- 35 mm thick polyurethane foam insulation.
- With adjustable shelving, fits containers up to GN 1/1.
- Digital display and electronic thermostat.
- With 4 adjustable plastic feet.
- Auto-defrost with condensation evaporator.
- Climate class: SN-T.
- Coolant: R600a.

### TWO DOOR REFRIGERATED COUNTER KITCHEN LINE 300L

- Chamber dimensions: 830x595x(H)500 mm.
- 2 shelves (335x570mm) included. Spread load capacity of 15 kg each.
- Weight: 70 kg.

code	range	V	W	mm
232019	-2°/8°C	230	220	900x700x(H)880



232019

Chamber and outer housing made of stainless steel

### THREE DOOR REFRIGERATED COUNTER KITCHEN LINE 380L

- Chamber dimensions: 1295x595x(H)500 mm.
- 3 shelves (335x570mm) included. Spread load capacity of 15 kg each.
- Weight: 91 kg.

code	range	V	W	mm
232026	-2°/8°C	230	220	1365x700x(H)880



232026

Shelve placing adjustable



Comfortable handles



Electronic temperature controller





## REFRIGERATOR & FREEZER COUNTERS KITCHEN LINE | 600 SERIES

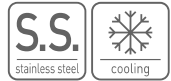

- Inner and outer housing are made of high-quality stainless steel
- Self-closing doors fitted with comfortable handles.
- Work surface fitted with a 40 mm high ridge at the back.
- Forced air cooling with auto-defrost, compressor placed underneath the chamber.
- 50 mm thick polyurethane foam insulation.

- With adjustable shelving.
- Digital display and electronic thermostat.
- With 4 adjustable stainless-steel feet.
- Climate class: SN-ST.
- Coolant: R600a.

**NEW!**



233344  
233351



233382  
233399

### TWO DOOR REFRIGERATED COUNTER KITCHEN LINE 220L

- Chamber dimensions: 800x480x(H)580 mm.
- 2 shelves (390x428mm) included. Spread load capacity of 15 kg each.
- Weight: 71 kg.

code	range	V	W	mm
233344	-2°/8°C	230	300	1200x600x(H)850

### THREE DOOR REFRIGERATED COUNTER KITCHEN LINE 390L

- Chamber dimensions: 1400x480x(H)580 mm.
- 3 shelves (2x 430x428mm, 1x 490x428mm) included. Spread load capacity of 15 kg each.
- Weight: 81 kg.

code	range	V	W	mm
233382	-2°/8°C	230	400	1800x600x(H)850

### TWO DOOR FREEZER COUNTER KITCHEN LINE 220L

- Chamber dimensions: 800x480x(H)580 mm.
- 2 shelves (390x428mm) included. Spread load capacity of 15 kg each.
- Weight: 71 kg.

code	range	V	W	mm
233351	-12°/-22°C	230	400	1200x600x(H)850

### THREE DOOR FREEZER COUNTER KITCHEN LINE 390L

- Chamber dimensions: 1400x480x(H)580 mm.
- 3 shelves (2x 430x428mm, 1x 490x428mm) included. Spread load capacity of 15 kg each.
- Weight: 81 kg.

code	range	V	W	mm
233399	-12°/-22°C	230	500	1800x600x(H)850

Shelve placing adjustable

Forced air cooling

Comfortable handles



**REFRIGERATOR & FREEZER COUNTERS PROFI LINE | 700 SERIES**

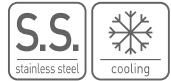

- Inner and outer housing are made of high-quality stainless steel, except the outer rear cover which is made of galvanized steel.
- Self-closing doors fitted with comfortable handles.
- Work surface fitted with a 40 mm high ridge at the back.
- Forced air cooling with auto-defrost, compressor placed underneath the chamber.

- 50 mm thick polyurethane foam insulation.
- With adjustable shelving, fits containers up to GN 1/1.
- Digital display and electronic thermostat.
- With 4 adjustable stainless-steel feet.
- Climate class: SN-T.



232040  
232064

232057  
232699

COOLING

**TWO DOOR REFRIGERATED COUNTER PROFI LINE 280L**

- Chamber dimensions: 822x570x(H)580 mm.
- 2 shelves (330x545mm) included. Spread load capacity of 40 kg each.
- Coolant: R600a.
- Weight: 95 kg.

code	range	V	W	mm
232040	-2°/8°C	230	250	1360x700x(H)850

**THREE DOOR REFRIGERATED COUNTER PROFI LINE 420L**

- Chamber dimensions: 1257x570(H)580 mm.
- 3 shelves (330x545mm) included. Spread load capacity of 40 kg each.
- Coolant: R290.
- Weight: 120 kg.

code	range	V	W	mm
232057	-2°/8°C	230	400	1795x700x(H)850

**TWO DOOR FREEZER COUNTER PROFI LINE 280L**

- Chamber dimensions: 822x570(H)580 mm.
- 2 shelves (330x545mm) included. Spread load capacity of 40 kg each.
- Coolant: R290.
- Weight: 95 kg.

code	range	V	W	mm
232064	-18°/-22°C	230	600	1360x700x(H)850

**THREE DOOR FREEZER COUNTER PROFI LINE 420L**

- Chamber dimensions: 1257x570x(H)580 mm.
- 3 shelves (330x545mm) included. Spread load capacity of 40 kg each.
- Coolant: R290.
- Weight: 120 kg.

code	range	V	W	mm
232699	-18°/-22°C	230	600	1795x700x(H)850



232071

**DRAWER WITH RAILS – 2-PIECE SET**

- Set to convert a door of a Profi Line 700 series counter into two drawers.

code
232071

## REFRIGERATED COUNTERTOP SERVERY

- Inner and outer housing are made of high-quality stainless steel.
- Static air cooling with auto-defrost, compressor placed next to the chamber.
- 40 mm thick polyurethane foam insulation.
- Digital display and electronic thermostat.
- With 4 adjustable plastic non-slip feet.
- Temperature range: -2/8°C.
- Climate class: SN.
- Coolant: R600a.
- All models delivered without GN containers.



**NEW!**



232965

4x GN 1/3



232903

5x GN 1/4



232972

6x GN 1/3



232910

7x GN 1/4



232989

7x GN 1/3



232927

8x GN 1/4



232996

9x GN 1/3

### REFRIGERATED COUNTERTOP SERVER GN 1/4

- With hardened glass display.
- Fits GN 1/4 containers with a max height of 150mm.

code	-	V	W	mm
232903	5x GN 1/4	230	180	1205x335x(H)430
232910	7x GN 1/4	230	180	1505x335x(H)430
232927	9x GN 1/4	230	180	1805x335x(H)430

### REFRIGERATED COUNTERTOP SERVER GN 1/3

- With hardened glass display.
- Fits GN 1/3 containers with a max height of 150mm.

code	-	V	W	mm
232965	4x GN 1/3	230	180	1205x395x(H)430
232972	6x GN 1/3	230	180	1405x395x(H)430
232989	7x GN 1/3	230	180	1605x395x(H)430
232996	9x GN 1/3	230	180	2006x395x(H)430

### REFRIGERATED COUNTERTOP SERVER GN 1/3

- With stainless steel lid.
- Fits GN 1/3 containers with a max height of 150mm.

code	-	V	W
233948	4x GN1/3	230	180
233955	6x GN1/3	230	180
233979	7x GN1/3	230	180
233986	8x GN1/3	230	180
233993	9x GN1/3	230	180



233948

**NEW!**



## SALAD COUNTERS

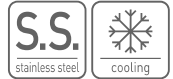

- Inner and outer housing are made of high-quality stainless steel.
- Doors fitted with comfortable handles.
- Forced air cooling with auto-defrost, compressor placed underneath the chamber.
- 35 mm thick polyurethane foam insulation.
- With adjustable shelving, fits containers up to GN 1/1.
- Digital display and electronic thermostat.
- With 4 adjustable plastic non-slip feet.
- Climate class: SN-T.
- Coolant: R600a.
- All models delivered without GN containers.



Delivered without GN containers

### TWO DOOR SALAD COUNTER 300L

- With stainless steel lid which covers space for 2x GN 1/1 and 3x GN 1/6 containers (max. height 150 mm).
- Chamber dimensions: 830x595x(H)500 mm.
- 2 shelves (335x570 mm) included. Spread load capacity of 15 kg each.
- Plastic work counter: 900x135x(H)20 mm.
- Weight: 68 kg.

code	range	V	W	mm
232804	-2°/8°C	230	310	900x700x(H)888



232804

Chamber and outer housing made of stainless steel



**NEW!**

### THREE DOOR SALAD COUNTER 380L

- With stainless steel lid which covers space for 4x GN 1/1 containers (max. height 150 mm).
- Chamber dimensions: 1295x595x(H)500 mm.
- 3 shelves (335x570 mm) included. Spread load capacity of 15 kg each.
- Plastic work counter: 1365x135x(H)20 mm.
- Weight: 87 kg.

code	range	V	W	mm
232811	-2°/8°C	230	310	1365x700x(H)888



232811

Shelve placing adjustable



Comfortable handles



Electronic temperature controller







232781

Chamber and outer housing made of stainless steel



232798

**TWO DOOR SALAD COUNTER WITH GLASS DISPLAY 300L**

- With stylish glass display, covers space for 2x GN 1/1 and 3x GN 1/6 containers (max. height 150 mm).
- Chamber dimensions: 830x595x(H)500 mm.
- 2 shelves (335x570 mm) included. Spread load capacity of 15 kg each.
- Plastic work counter: 900x135x(H)20 mm.
- Weight: 80 kg.

code	range	V	W	mm
232781	-2°/8°C	230	310	900x700x(H)1300

**THREE DOOR SALAD COUNTER WITH GLASS DISPLAY 380L**

- With stylish glass display, covers space for 4x GN 1/1 containers (max. height 150 mm).
- Chamber dimensions: 1295x595x(H)500 mm.
- 3 shelves (335x570 mm) included. Spread load capacity of 15 kg each.
- Plastic work counter: 1365x135x(H)20 mm.
- Weight: 110 kg.

code	range	V	W	mm
232798	-2°/8°C	230	310	1365x700x(H)1300



232880

Chamber and outer housing made of stainless steel



232897

**TWO DOOR SALAD COUNTER WITH RAISED GN DISPLAY 300L**

- With stainless steel lid which covers space for 5x GN 1/6 containers (max. height 150 mm).
- Chamber dimensions: 830x595x(H)500 mm.
- GN display dimensions: 900x265x(H)195 mm.
- 2 shelves (335x570 mm) included. Spread load capacity of 15 kg each.
- Weight: 75 kg

code	range	V	W	mm
232880	-2°/8°C	230	310	900x700x(H)1040

**THREE DOOR SALAD COUNTER WITH RAISED GN DISPLAY 380L**

- With stainless steel lid which covers space for 8x GN 1/6 containers (max. height 150 mm).
- Chamber dimensions: 1295x595x(H)500 mm.
- GN display dimensions: 1365x265x(H)195 mm.
- 3 shelves (335x570 mm) included. Spread load capacity of 15 kg each.
- Weight: 105 kg

code	range	V	W	mm
232897	-2°/8°C	230	310	1365x700x(H)1040



## PIZZA COUNTERS

- Inner and outer housing are made of high-quality stainless steel, with granite worktop.
- Doors fitted with comfortable handles.
- Forced air cooling with auto defrost, compressor placed underneath the chamber.
- With adjustable shelving, fits containers up to GN 1/1.



- Digital display and electronic thermostat.
- Width 4 adjustable plastic non-slip feet.
- Climate class: SN-T.
- Coolant: R600a.
- All models delivered without GN containers.



232859



### TWO DOOR PIZZA COUNTER 300L

- With stainless steel cover around the GN space which fits 5x GN 1/6 containers (max. height 150 mm).
- Chamber dimensions: 830x595x(H)500 mm.
- 35 mm thick polyurethane foam insulation.
- 2 shelves (335x570 mm) included. Spread load capacity of 15 kg each.
- Weight: 94 kg.

code	range	V	W	mm
232859	-2°/8 °C	230	310	900x700x(H)1100

Chamber and outer housing made of stainless steel



232873

**NEW!**

### THREE DOOR PIZZA COUNTER 380L

- With glass cover around the GN space which fits 8x GN 1/6 containers (max. height 150 mm).
- Chamber dimensions: 1295x595x(H)500 mm.
- 35 mm thick polyurethane foam insulation.
- 3 shelves (335x570 mm) included. Spread load capacity of 15 kg each.
- Weight: 180 kg.

code	range	V	W	mm
232873	-2°/8 °C	230	310	1360x700x(H)1120



Countertop servers on page 225



232996

**TWO DOOR PIZZA COUNTER WITH SEVEN DRAWERS 280L**

- Equipped with 7 uncooled drawers of 400x620x(H)65 mm.
- Chamber dimensions: 1480x670x(H)570 mm.
- 60 mm thick polyurethane foam insulation.
- 2 shelves (600x400mm) included. Spread load capacity of 15 kg each.
- Weight: 367 kg.

code	range	V	W	mm
232842	-2°/8°C	230	250	2020x800x(H)1110



232842

Chamber and outer housing made of stainless steel



**THREE DOOR PIZZA COUNTER WITH COOLING DISPLAY 380+40L**

- With separate cooling display which fits 6x GN 1/4 containers (max. height 150 mm).
- Cooling display cools by means of static cooling.
- Cooling display dimensions: 1405x335x(H)255 mm.
- Chamber dimensions: 1295x595x(H)500 mm.
- 35 mm thick polyurethane foam insulation.
- 3 shelves (335x570 mm) included. Spread load capacity of 15 kg each.
- Weight: 190+41 kg.

code	range	V	W	mm
232033	-2°/8°C	230	220+180	1405x700x(H)1445



232033



## BLAST CHILLERS

- Enables quick chilling or freezing of prepared dishes.
- Chilling from 70°C to 3°C (90 mins), from 70° C to -18°C (240 mins) or within a pre-set time (without indicating the target temperature).
- Outer housing and inner chamber made of high-quality stainless steel.
- Inner chamber with rounded corners for easier cleaning.
- Forced air cooling with auto-defrost, compressor placed underneath the chamber.

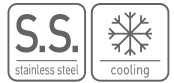

- 60 mm thick polyurethane foam insulation.
- Removable top cover.
- Self-closing door with magnetic gasket.
- Digital temperature controller and display.
- Probe included.
- Fitted with 4 adjustable stainless steel feet.
- Climate class: SN-T
- Coolant: R404a/R507.

### Blast chilling from +90°C to +3°C

This process helps lower the food temperature to safe +3°C in a suitably short time, in line with HACCP standards. The adequate chilling speed helps reduce bacteria growth in the range from +65°C to +10°C. Blast chilling helps retain the quality, colour and smells of food and extends the storage period.

### Blast freezing from +90°C to -18°C

Powerful chilling system and blowing air of -40°C into the chamber makes the core temperature of food quickly drop to -18°C. It prevents large ice crystals from occurring, which damage the internal structure of food. Blast freezing results in a large number of small crystals which preserves the original properties of food: flavour, colour, texture and nutrients, and helps extend the storage period.

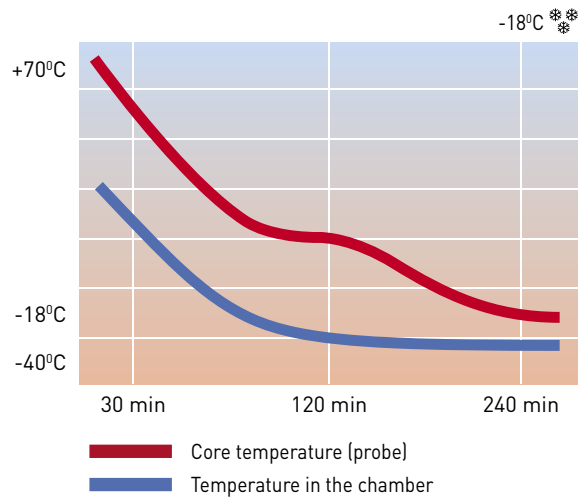
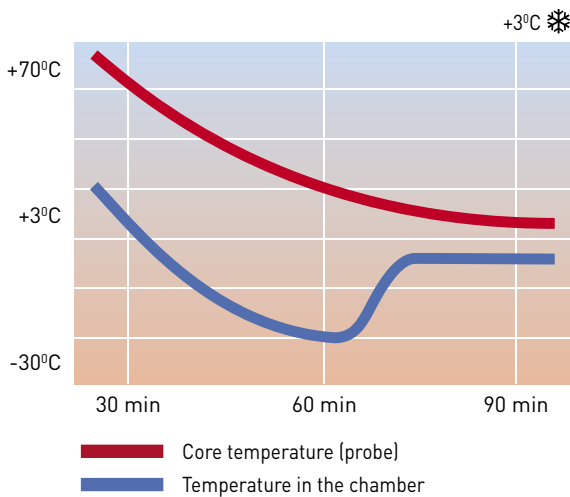

Probe included

Chamber with rails (70 mm apart) compatible with GN 1/1 and 600x400 mm baking sheets.







232163

**BLAST CHILLER 3 X GN 1/1**

- Chamber capacity: 3 x GN 1/1 or 3 x 600x400 mm trays.
- Inside dimensions of the chamber: 610x410x280 mm.
- 3 sets of rails, 70 mm apart.
- Output at chilling to +3° C: 14 kg.
- Output at freezing to -18°C: 11 kg.
- Weight: 50 kg.

code	V	W	mm
232163	230	1150	750x740x(H)720/750



232170

**BLAST CHILLER 5 X GN 1/1**

- Chamber capacity: 5 x GN 1/1 or 5 x 600x400 mm trays.
- Inside dimensions of the chamber: 610x410x410 mm.
- 5 sets of rails, 70 mm apart.
- Output at chilling to +3° C: 20 kg.
- Output at freezing to -18°C: 15 kg.
- Weight: 71 kg.

code	V	W	mm
232170	230	1420	750x740x(H)850/880

Chamber and outer housing made of stainless steel



232194

**BLAST CHILLER 7 X GN 1/1**

- Chamber capacity: 7 x GN 1/1 or 7 x 600x400 mm trays.
- Inside dimensions of the chamber: 610x410x760 mm.
- 7 sets of rails, 105 mm apart.
- Output at chilling to +3° C: 25 kg.
- Output at freezing to -18°C: 20 kg.
- Weight: 90 kg.

code	V	W	mm
232194	230	1490	750x740x(H)1260/1290



232187

**BLAST CHILLER 10 X GN 1/1**

- Chamber capacity: 10 x GN 1/1 or 10 x 600x400 mm trays
- Inside dimensions of the chamber: 610x410x760 mm
- 10 sets of rails, 70 mm apart
- Output at chilling to +3° C: 25 kg
- Output at freezing to -18°C: 20 kg
- Weight: 90kg

code	V	W	mm
232187	230	1490	750x740x(H)1260/1290



REFRIGERATORS & FREEZERS

COOLING



**DISPLAY TRAY SILVER COLOR**



code	mm
808511	600x400x(H)20
808504	400x300x(H)20



**DISPLAY TRAY GOLD COLOR**



code	mm
808573	600x400x(H)20
808566	400x300x(H)20



568200

**MEAT TRAY**  
- Black melamine

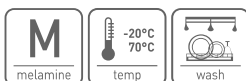

code	mm
568101	290x160x(H)35
568200	350x250x(H)40
568309	420x280x(H)60



568507

**MEAT TRAY**  
- Black melamine

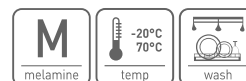

code	mm
568408	290x160x(H)60
568507	300x190x(H)80



568804

**MEAT TRAY**  
- Black melamine

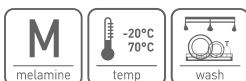

code	mm
568804	280x210x(H)60



569108

**DISPLAY TRAY**  
- Black melamine

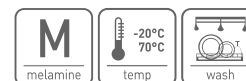

code	mm
569009	270x210x(H)17
569016	300x150x(H)17
569108	300x190x(H)17
569207	350x240x(H)17



407202

**DISPLAY TRAY**  
- With feet



code	mm
407202	240x170



407400

**DISPLAY TRAY**



code	mm
407400	345x245



408308

**DISPLAY TRAY**



code	mm
408308	310x230



508305

**MEAT TRAY**



code	mm
508107	260x200x(H)48
508206	310x240x(H)48
508305	360x275x(H)52



429419

**BREADROLL DISPENSER**  
- For 7 rolls



code	mm
429419	475x105x(H)60





Two castors have brakes

Equipped with a simple locking system



**CLEARING TROLLEY - 7 X GN 1/1**

- Designed to fit GN 1/1 Trays/containers
- With working surface
- Tray locks on either side
- Fitted with four castors of which two have brakes
- Flatpack delivery

**CLEARING TROLLEY - 15 X GN 1/1**

- GN 1/1 with 15 layers - interspaced at 80mm
- Tray locks on either side
- Fitted with four castors of which two have brakes
- Flatpack delivery

**CLEARING TROLLEY 15 - 600X400**

- 600x400 mm 15 layers - interspaced at 80mm
- Tray locks on either side
- Fitted with four castors of which two have brakes
- Flatpack delivery

code	work top (mm)	mm	code	mm	code	mm
810668	GN 1/1 - 530x325	380x550x(H)925	810613	615x450x(H)1695	810651	690x515x(H)1695





810606

In order to save space during storage trolleys can be pushed into one another



### CLEARING TROLLEY COMPACT STORAGE - 15 X GN 1/1

- In order to save space during storage trolleys can be pushed into one another.
- GN 1/1 with 15 layers - interspaced at 80mm.
- Tray locks on either side.
- Fitted with four castors of which two have brakes.
- Flatpack delivery.

code	mm
810606	380x550x (H)1700



810002

### SERVING TROLLEY

- Made of stainless steel.
- Fitted with 2 shelves and sound insulation material underneath.
- Maximum load per tray 50 kg.
- Includes 4 castors, of which 2 with brakes, fitted with corner protection.
- Distance between trays 550 mm.
- Flatpack delivery.

code	work top (mm)	mm
810002	830x510	910x590x(H)950



810101

### SERVING TROLLEY

- Made of stainless steel.
- 3 shelves with noise reducing material underneath.
- Maximum load per tray 50 kg.
- Includes 4 castors, of which 2 with brakes, fitted with corner protection.
- Distance between trays 295 mm.
- Flatpack delivery.

code	work top (mm)	mm
810101	830x510	910x590x(H)950





### SERVING TROLLEYS WITH WOOD PATTERN PRINT

- Made of stainless steel.
- Fitted with 3 shelves.
- Maximum load per shelf 50 kg.
- Includes 4 castors, of which 2 with brakes, fitted with corner protection.
- Flatpack delivery.

code		work top (mm)	mm
810149	oak wood pattern print	830x510	910x590x(H)950
810156	dark oak wood pattern print	830x510	910x590x(H)950 <b>NEW!</b>



Collapsible to minimize transport dimensions



### PLATFORM TROLLEY

- Despite its low weight it can carry up to 150 kg.
- Collapsible to minimize transport dimensions.
- With two castor wheels.

code	mm
810514	730x480x(H)825



### SERVING TROLLEY POLYPROPYLENE

- Made of polypropylene
- Fitted with 3 shelves
- Maximum load per tray 50 kg
- Includes 4 castors, of which 2 with brakes, fitted with corner protection
- Distance between trays 340 mm

code	work top (mm)	mm
810200	615x400	800x410x(H)950

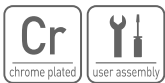

### STORAGE RACK WITH 5 SHELVES

- Maximum load per shelf 80 kg
- Fitted with adjustable feet
- Chrome-plated iron

code	mm
812204	910x455x(H)1830

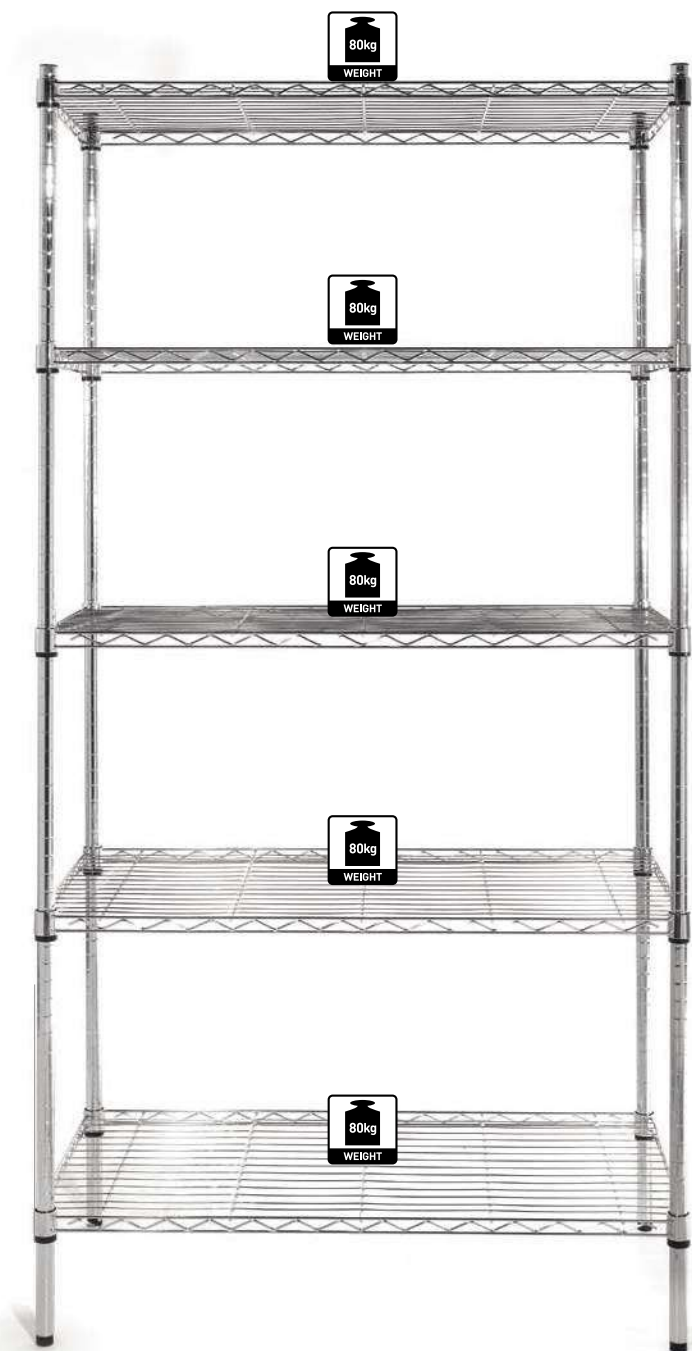

812204





## ALUMINIUM STORAGE RACK FOR GN CONTAINERS



- GN 1/1 containers fit directly between the aluminum supports.
- Anodized aluminium frame.
- With dishwasher safe polypropylene shelves.
- Easily expandable.
- Carrying capacity 150 kg, distributed across the surface.



### ALUMINIUM STORAGE RACK FOR GN CONTAINERS

code	mm
812266	1120x355x(H)1685
812372	connecting hook

812266

STORAGE & TRANSPORT



Easily expandable



Plastic shelves can be cleaned in a dishwasher





## STORAGE RACKS

- Anodized aluminium frame.
- With dishwasher safe polypropylene shelves.
- Easily expandable.
- Carrying capacity 150 kg, distributed across the surface.



### ALUMINIUM STORAGE RACK

code	mm
812273	1280x405x(H)1685
812280	connecting hook

812273



Easily expandable



Plastic shelves can be cleaned in a dishwasher





**MAX**  
103 kg



877920



scoop



transparent cover



four torsional wheels

### INGREDIENT TROLLEY

- Useful in any large kitchen to store, transport and quick measure of quantities of dry food such as: flour, sugar, salt, groats, rice.
- One-piece, solid and sturdy polyethylene structure.
- Rounded corners and smooth inner walls are ideal for easy cleaning.
- Guides located in the upper, inner part of the trolley permit the comfortable fitting of the scoop.
- Transparent polycarbonate lid for easy identification or product type and quantity.
- Four wide, rubber wheels ø75 mm, including two castor wheels with brakes for easier transport.
- Ergonomic height of 71 cm ideal to put under a worktable.

code	liter	mm ext.
877920	98	394x749x(H)711
877913	81	333x743x(H)711 <b>NEW!</b>

STORAGE & TRANSPORT

For dry food:



flour



sugar



salt



cereal



rise



877937



distance between shelves 270/290 mm



four torsional wheels



### SERVING TROLLEY 3 SHELVES

- Designed for restaurants, bars, catering establishments and wherever it is necessary to quickly, efficiently and safely take tableware
- Polyethylene shelves, aluminium frame
- Easy to clean
- Distance between shelves 270/290mm
- Allowed load: 103kg

code	work top (mm)	mm
877937	750x500(H)20	1280x500x(H)960



### INSULATED ICE CONTAINER - 110 L

- Ideal to transport ice cubes or flakes over long distances.
- Robust polyethylene housing resistant to shocks and impact.
- Thick foam insulation to keep ice temperature as long as possible.
- Inner walls resistant to scratches and stains.
- Sliding, sealed lid allowing easy scooping of ice.
- Ergonomic grip integrated with housing.
- Two large wheels resistant to uneven ground and two smaller castor wheels with brake.
- Profiled drain for melted ice in chamber, with tap.
- Delivered ready-to-use, does not require assembly.
- 4 wheels, 2 with brakes (large  $\varnothing 20$  mm, small  $\varnothing 10$  mm).
- Tap, scoop and drip tray included.

code	liter	mm ext.
877883	110	585x800x(H)745

# AMER★BOX



## MAX 110 L



877883



drip tray



2 torsion wheels with brakes



tap



scoop



### PLATE TROLLEY

- Assures safe transport of tableware.
- Mobile polyethylene guards make it possible to load plates of various sizes.
- Extremely robust design made of polyethylene protects the tableware from chipping or breaking.
- Number of plates stacks: 6.
- Number of plates per stack: 50.
- Wheels resistant to uneven ground, non-marking even at full load.
- Two castor wheels with brakes  $\varnothing 10$  mm, large wheels  $\varnothing 20$  mm.
- Shock and impact resistant.
- Vinyl cover to meet strict sanitary standards included.
- Plates diameter from  $\varnothing 170$  to  $\varnothing 330$  mm.

code	mm ext.
877906	930x720x(H)800



877906



Includes vinyl cover with every caddy for sanitary storage



up to 50 plates in one stack



front wheels with brakes

### Examples of sets



4 columns - plates of  $\varnothing 230$ -335mm



6 columns - plates of  $\varnothing 118$ -230 mm



4 columns - plates of  $\varnothing 115$  mm  
2 columns - plates of  $\varnothing 140$  mm  
2 columns - plates of  $\varnothing 230$  mm



5 columns - plates of  $\varnothing 128$  mm  
2 columns - plates of  $\varnothing 231$  mm



5 columns - plates of  $\varnothing 102$  mm  
2 columns - plates of  $\varnothing 334$  mm





877845



4 latches



vent cup



877852



### INSULATED CATERING CONTAINER GN 1/1, TOP-LOADED

- Made of HDPE polyethylene.
- Double walls filled with high quality polyurethane foam assure perfect insulation and long holding of food temperature.
- Tight lid with 4 clamps made of tough nylon.

code	mm int.	mm ext.
877845	GN 1/1 - 150	630x440x(H)260
877852	GN 1/1 - 200	630x440x(H)305

#### Example of sets



1x GN 1/1



2x GN 1/2



2x GN 1/4  
1x GN 1/2



1x GN 2/3  
1x GN 1/3



3x GN 1/3



4x GN 1/4



2x GN 1/6  
2x GN 1/3



6x GN 1/6

#### Temperature retention

hot

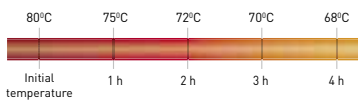

cold

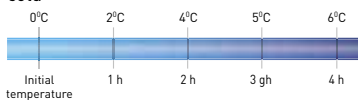

4 heavy duty clamps

place for sticker



877869



877876



### INSULATED BEVERAGE DISPENSER WITH TAP

- Ideal for storage, transport and serving of hot and cold drinks.
- Robust LDPE polyethylene housing.
- Good polyurethane foam insulation.
- 4 heavy duty clamps, 25 mm wide, at either side of the jug, for easy and quick opening and closing.
- Comfortable transport grips.
- Tap distance from the floor: 95 mm.
- Recessed tap - protection against transport damage.
- Delivered with stickers for quick identification of drinks.
- Vent for easier lid opening.
- Shock and impact resistant.
- Rounded chamber with grooves leading to the tap.

code	liter	mm ext.
877869	9,4	230x420x(H)470
877876	18	230x420x(H)620



877814



### Temperature retention

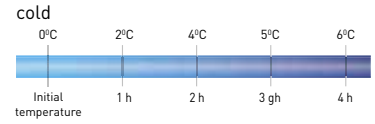
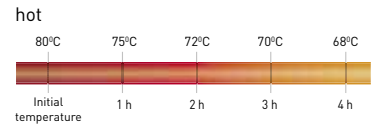

### Examples of sets

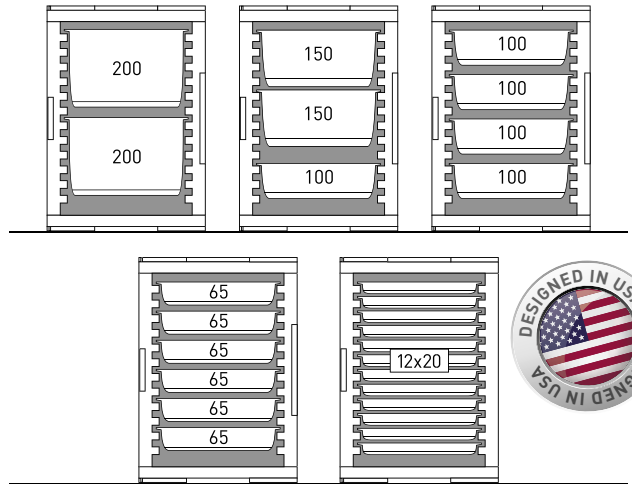

877821

2 wheels with brakes

## THERMO CATERING CONTAINER 2X GN 1/1 200

- Double-walled insulated polyethylene LDPE - impact resistant hard polyethylene.
- Keeps hot and cold.
- With 2 sturdy carrying handles.
- Press-formed guides fitted in chamber housing.
- Inside dimensions: 335x533x(H)590 mm.
- Suitable for 1/1 Gastronorm trays:
- Gastronorm tray 10 mm deep: 12 pieces.
- Gastronorm tray 65 mm deep: 6 pieces.
- Gastronorm tray 100 mm deep: 4 pieces.
- Gastronorm tray 150 mm deep: 2 pieces plus 1 Gastronorm tray 100 mm deep.
- Gastronorm tray 200 mm deep: 2 pieces.

code	mm int.	mm ext.
877814	335x533x(H)590	477x680x(H)620

## TROLLEY FOR THERMO CONTAINER

code	mm ext.
877821	530x710x(H)230

## HEATING ELEMENT GN 1/1

- Can be heated up to 90°C.
- For use in: 707814, 707609, 707999, 707661.
- To heat the element, place it in a stainless steel container and place in a convection oven, max 90°C for max. 40 minutes.

code	mm
707845	560x325x(H)30

## COOLING ELEMENT GN 1/1

- Can be cooled to -18°C.
- For use in: 707814, 707609, 707999, 707661.

code	mm
707821	530x325x(H)30



**NEW!**





707661

**THERMO CATERING BOX**

- Ultra-lightweight, durable container with perfectly sealable opening.
- Removable door – even if the boxes are stacked
- With 5 grooves spaced 65 mm apart to slide in containers, fits GN1/1 containers.
- The high stacking ledges with locking profile ensures stable stacking without sliding.
- Fits perfectly on Euro pallets – four boxes per layer

code	liter	mm int.	mm ext.
707661	66	535x310x(H)400	600x400x(H)490



707845

**NEW!****HEATING ELEMENT GN 1/1**

- Can be heated up to 90 °C.
- For use in: 707814, 707609, 707999, 707661.
- To heat the element, place it in a stainless steel container and place in a convection oven, max 90 °C for max. 40 minutes.

code	mm
707845	560x325x(H)30



Fits perfectly on Euro pallets  
– four boxes per layer



### THERMO CATERING BOX

- Ultra-lightweight, durable container with perfectly sealable opening.
- Suitable for Gastronorm 1/1 containers.
- With 8 grooves spaced 61 mm apart to slide in GN containers.
- The high stacking ledges with locking profile ensures stable stacking without sliding.

code	liter	mm int.	mm ext.
707999	100	550x335x(H)545	635x465x(H)660



707999

707821



### COOLING ELEMENT GN 1/1

- Can be cooled to -18°C.
- For use in: 707814, 707609, 707999, 707661.

code	mm
707821	530x325x(H)30

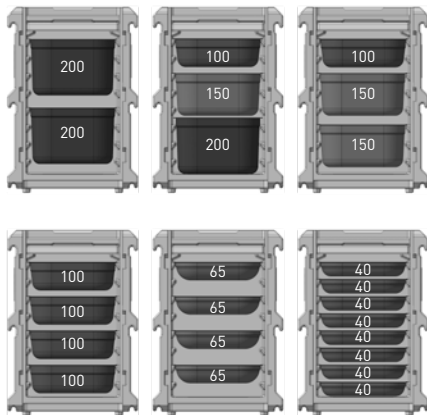





707982

STORAGE & TRANSPORT



### THERMOBOX PROFI LINE

- Perfect for transport of hot or cold products.
- The special heat-sealed inner lining provides reinforcement, facilitates easy cleaning and substantially improves the useful life.
- The thermobox is suitable for containers sizes up to Gastronorm 1/1.
- Expanded polypropylene (EPP) boxes have a sealed structure which provides exceptional insulation, up to 50% better than other Hendi thermoboxes.
- Temperature resistant from -20°C up to 110°C
- Practical integrated handles allow for comfortable carrying.
- The thermoboxes are stackable both with and without lids.



code	-	liter	mm int.	mm ext.
707982	Gastronorm 1/1	39	538x338x(H)217	674x400x(H)287







707968

707951

### THERMOBOX KITCHEN LINE

- Perfect for transport of hot or cold products.
- The shaped foam polypropylene (EPP) containers offer high insulation levels.
- Withstands temperatures ranging from -20°C to +110°C.
- With recessed handles at the side.

code		liter	mm ext.	mm int.
707975	Pizza	21	410x410x(H)240	350x350x(H)175
707906	Gastronorm 1/1	40	600x400x(H)285	538x338x(H)234
707968	Gastronorm 1/1	46	600x400x(H)320	538x338x(H)257
707951		53	685x485x(H)260	625x425x(H)200
707944		80	685x485x(H)360	625x425x(H)300



707975



707814



### COOLING ADAPTOR EPP GN 1/1

- Place this adaptor with cooling element on top of your Thermobox Kitchen Line GN 1/1 and keep the goods cold for extra long periods of time.
- Supplied without cooling element.
- Fits on top of 707906 and 707968.

code	mm
707814	600x400x(H)85



707821



### COOLING ELEMENT GN 1/1

- Can be cooled to -18°C.
- For use in: 707814, 707609, 707999, 707661.

code	mm
707821	530x325x(H)30





710203

STORAGE & TRANSPORT

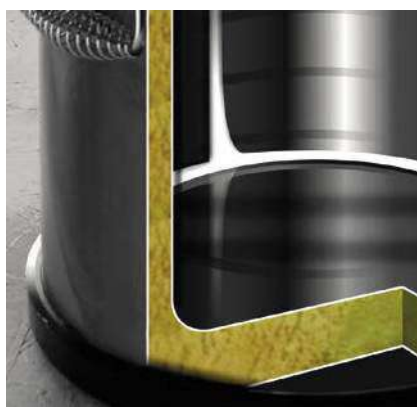

**INSULATED PORTABLE CONTAINER**

- Space between the walls is filled with special insulating material which keeps hot or cold temperature of food for up to 6-8 hours
- Double lid secured with a seal and equipped with 6 latches
- Air valve
- Two handles for transport
- Flexible material protects the container and the floor against damage
- Stackable

code	liter	mm ext.
710104	10	ø330x(H)220
710203	20	ø330x(H)360
710302	35	ø330x(H)570



Top and bottom shelf are reinforced



810705

### WORK TABLE

- Height-adjustable legs.
- Both top and bottom shelf reinforced.
- Robust construction.

code	mm
810705	1000x700x(H)850
810712	1200x700x(H)850
810729	1400x700x(H)850
810736	1600x700x(H)850
810743	1800x700x(H)850

### DOUBLE ADJUSTABLE WALL SHELF

- Two levels.
- With backslash for maintaining hygiene.
- 1800 mm wide shelf supplied with 3 reinforced brackets.
- Removable for cleaning.

code	mm
970232	1000x355x(H)600
970249	1200x355x(H)600
970256	1400x355x(H)600
970270	1800x355x(H)600



970232



# NEW!

# NEW!

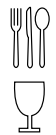

max H  
290 mm

230299



max H  
335 mm

230305

## GLASS DISHWASHER K40

- Suitable for baskets of 400x400 mm, max glass height 290 mm.
- Separate stainless steel rotating spray arms for washing and rinsing.
- Fitted with solid double skinned door with two hinges, needs 325mm of space to open completely.
- Boiler capacity of 6 liter (2,5kW), tank capacity of 35 liter (2,5kW).
- Water pump (0,1HP) with IP44 protection class.
- With thermometer for reading the boiler temperature.
- Weight: 39 kg.
- Accessories supplied with the dishwasher
  - basket for glasses (400x400x(H)150 mm)
  - basket for glasses with 40 support pins (400x400x(H)110 mm)
  - cutlery basket (110x110x(H)130 mm)
  - water hose with 3" inner thread connection (150cm)
  - drain hose ø25mm (200cm)
  - power cord without plug
  - rinse aid dispenser

## DISHWASHER K50

- Suitable for baskets of 500x500 mm, max glass height 325 mm, max plate height 335 mm.
- Fitted with multiple sprayers and spray arms.
- Separate rotating spray arms for washing (plastic) and rinsing (stainless steel), and fixed upper sprayers for washing.
- Fitted with solid double skinned door with two hinges, needs 370mm of space to open completely.
- Boiler capacity of 6 liter (6kW), tank capacity of 35 liter (6kW)
- Powerful water pump (0,75HP) with IP44 protection class
- With thermometer for reading the boiler temperature.
- Weight 57 kg
- Accessories supplied with the dishwasher
  - basket for glasses (500x500x(H)105 mm)
  - basket for plates (500x500x(H)105 mm)
  - cutlery basket (110x110x(H)130 mm)
  - water hose with 3" inner thread connection (150cm)
  - drain hose ø25mm (200cm)
  - power cord without plug
  - rinse aid dispenser

HYGIENE



code		V	kW	mm
230299	dishwasher K40	230	2,8	470x510x(H)710
233009	with detergent pump	230	2,8	470x510x(H)710
233016	with drain pump	230	2,8	470x510x(H)710
233023	with drain & detergent pump	230	2,8	470x510x710

code		V	kW
230305	dishwasher K50	400	6,6
233030	with detergent pump	400	6,6
233047	with drain pump	400	6,6
233054	with drain & detergent pump	400	6,6
231050	stand for dishwasher K50	560x560x(H)500	



**NEW!**



230312



max H  
400 mm

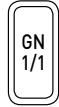

**HOOD DISHWASHER K1500**

- Easy to open thanks to a spring supported raising system for the hood.
- The dishwasher is 1830 mm high when the hood is raised.
- Suitable for baskets of 500x500 mm, max glass height 395 mm, max plate height 400 mm.
- Separate stainless steel rotating spray arms for washing and rinsing.
- Boiler capacity of 7,4 liter (7,5kW), tank capacity of 58 liter (6kW)
- Powerful water pump (1,5HP) with IP44 protection class
- With separate thermometer for reading the boiler and tank temperature.
- With 4 surface filters in the tank and a sieve filter covering the pump inlet.
- Weight 111 kg
- Accessories supplied with the dishwasher
  - basket for glasses (500x500x(H)105 mm)
  - basket for plates (500x500x(H)105 mm)
  - cutlery basket (110x110x(H)130 mm)
  - water hose with 3" inner thread connection (150cm)
  - drain hose ø25mm (200cm)
  - power cord without plug
  - rinse aid dispenser

code		V	kW	mm
230312	dishwasher K1500	400	8,6	750x880x(H)1390
233061	with detergent pump	400	8,6	750x880x(H)1390

**NEW!**



231777



**LOADING TABLE WITH SINK FOR DISHWASHER**

- Made of durable stainless steel, with a 510 mm wide basket guide, backsplash and integrated sink (400x400mm).
- Equipped with a catch for hood dishwashers.
- The legs are adjustable in height to guarantee a level installment.
- Flat pack delivery, needs assemblage.
- Versions available for left & right side instalment.

code	mm	model
231777	1000x700x(H)880	left side
231791	1000x700x(H)880	right side

**NEW!**



231760



**UNLOADING TABLE FOR DISHWASHERS**

- Made of durable stainless steel, with a 510 mm wide basket guide and backsplash.
- Equipped with a catch for hood dishwashers.
- The legs are adjustable in height to guarantee a level installment.
- Flat pack delivery, needs assemblage.
- Versions available for left & right side installment.

code	mm	model
231760	1000x600x(H)880	left side
231784	1000x600 x(H)880	right side



## DISHWASHER RACKS & TOTE BOX



877050



877548



877043



877531



877036



877524



877029



877517



877012



877500

**NEW!**

**NEW!**

### DISHWASHER BASKET FOR GLASSWARE

code		mm
877050	9-compartment	500x500x(H)104
877043	16-compartment	500x500x(H)104
877036	25-compartment	500x500x(H)104
877029	36-compartment	500x500x(H)104
877012	49-compartment	500x500x(H)104

### EXTENDER FOR DISHWASHER BASKET

code		mm
877548	9-compartment	500x500x(H)45
877531	16-compartment	500x500x(H)45
877524	25-compartment	500x500x(H)45
877517	36-compartment	500x500x(H)45
877500	49-compartment	500x500x(H)45

HYGIENE



877005



877104



877203

### DISHWASHER UNIVERSAL BASKET

- Suitable for cups, pots, bowls, etc.
- The structure allows for maximum flow of water between the dishes in all directions
- With coarse mesh bottom

### DISHWASHER BASKET FOR PLATES

- The structure allows for maximum flow of water between the dishes in all directions
- With pre-shaped pins
- The spaces between separators create the optimum tilt of plates necessary for effective washing

### DISHWASHER BASKET FOR CUTLERY

- The structure allows for maximum flow of water between the dishes in all directions
- The fine mesh bottom prevents cutlery from falling through

code	mm
877005	500x500x(H)100

code	mm
877104	500x500x(H)100

code	mm
877203	500x500x(H)100

# NEW!



877128

### DISHWASHER BASKET FOR CUPS

- The structure allows for maximum flow of water between the dishes in all directions  
- 16 sections

code	mm
877128	500x500x(H)100

# NEW!



877111

### DISHWASHER BASKET FOR TRAYS

- The structure allows for maximum flow of water between the trays in all directions  
- With pre-shaped pins  
- With one open end to trays and other long items

code	mm
877111	500x500x(H)100

# NEW!



871348

871331

### DISHWASHER BASKET FOR GLASSES

- The structure allows for maximum flow of water between the glasses in all directions.

code	mm
871331	400x400x(H)150
871348	400x400x(H)110

with 40 support pins



# NEW!

### LID FOR RACKS

code	mm
877180	500x500



877180

# NEW!



### CLIPS FOR RACKS

code	colour
877234	white
877241	black
877258	blue
877265	yellow
877272	red
877289	green
877296	brown



871102



871300

871324

### CUTLERY BASKET

- 8 sections with handle

code	mm
871102	425x205x(H)150



### CUTLERY BASKET

code	colour	mm
871300	white	110x110x(H)140
871324	blue	125x84x(H)135



877197

### TROLLEY FOR DISHWASHER RACKS WITH HANDLE

- 4 wheels, 2 revolving with brake and 2 fixed.  
- Stainless steel handle.

code	mm
877197	575x545x(H)920



# NEW!



552001

### TOTE BOX

- Grey, with handles

code	mm
552001	555x410x(H)130



877173

### TROLLEY FOR DISHWASHER RACKS

- 4 wheels, 2 revolving with brake and 2 fixed

code	mm
877173	575x545x(H)210



# NEW!



## WATER SOFTENERS

- Using water softeners helps extend the life cycle of catering equipment.
- The softeners are based on an ion-exchange process wherein the calcium and magnesium ions that cause water hardness are captured by ion exchange resin inside the softener. It helps reduce maintenance costs thanks to effective prevention of lime scale deposits
- The device is fitted with a control head that makes it possible to configure working parameters of the water softening system as required.
- The elements inside the head are made of high quality ceramics, resistant to abrasion, corrosion and build-up of impurities (e.g. iron). This technology assures perfect seal

**NEW!**

- inside the controller and therefore long and trouble-free operation.
- Navy blue housing.
- Water connection diameter 3/4".
- Working pressure: 1.5-6.0 bar.
- Working ambient temperature: 5 - 38°C.
- Max. supply water temperature: 38°C.
- Regeneration time: 37 min.
- Output for 10°dH - 1200 L.
- Resin bed 4,0 L.
- Regeneration tank: 8 kg.
- Maximum water flow: 5 L/min.
- Regeneration salt consumption per 1 cycle: 0.5 kg.



230442



230459

### WATER SOFTENER, SEMI-AUTOMATIC

- The semi-automatic resin bed regeneration process using brine is initiated manually.
- Weight: 8 kg.

code	mm	V	W
230442	195x360x(H)x510	230	18

### WATER SOFTENER, AUTOMATIC

- The automatic resin bed regeneration process using brine is initiated automatically.
- Using the control panel the working time, regeneration time and water amount to be treated can be set.
- Automatic lock prevents unwanted access.
- Weight: 7.7 kg.

code	mm	V	W
230459	206x380x(H)480	230	18



231265



### SALT TABLETS FOR WATER SOFTENING

- Ingredients: sodium chloride NaCl

code	bag 25 kg
231265	bag 25 kg





## WATER SOFTENERS

- Hard water contains dissolved minerals - calcium and magnesium compounds, among others. Calcium and magnesium ions cause scale build-up, which is risky for objects and tools in contact with water or steam. Water softening is a process in which all calcium and magnesium compounds causing water hardness are removed. When passing through the resin column, calcium and magnesium ions are absorbed by resin particles. When ion-exchange ability of the resin wears off, it ought to be restored in an appropriate regeneration process with the use of a salt solution
- Water softener may be installed wherever water temperature

- is below 45°C and the water input pressure does not exceed 2 bars
- Regeneration: uniodised salt only
- For drinking water only
- Suitable for softening water for coffee makers, combi steamers, dishwashers and ice cubers.
- Thanks to its small size it is perfect for bars and restaurants
- Thanks to highest quality components used, the device remains fail-safe and operational for many years.
- Optimum working water pressure: 1-2bar



### WATER SOFTENER

- During softener regeneration the connected machine must not be used.
- Maximum/minimum water pressure: from 1 to 8 bar.
- Nominal flow: 1000 L/h.
- Ambient temperature: from 4°C to 35°C.
- supply water temperature: from 4°C to 25°C.
- Connection size: 3/8".



code		weight (kg)	liter	mm
231210	Filter capacity (20°F/30°F/40°F) 1200/1000/900	1	8 l / 7,5 kg	ø185x(H)400
231227	Filter capacity (20°F/30°F/40°F) 2520/1680/1260	1,5	12 l / 8,4 kg	ø185x(H)500
231234	Filter capacity (20°F/30°F/40°F) 3360/2240/1680	2	16 l / 11,2 kg	ø185x(H)600



### SALT TABLETS FOR WATER SOFTENING

- Ingredients: sodium chloride NaCl

code	
231265	bag 25 kg



## INSECT KILLERS FOR USE IN THE KITCHEN & RESTAURANT



270189

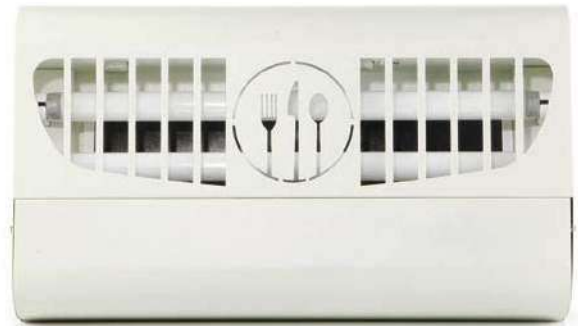

270080



270226



270219



270073



270028



### INSECT KILLER WITH ADHESIVE PLATE 80M<sup>2</sup>

- Suitable for use in food preparation and serving areas.
- ABS fire-resistant casing suitable for wall mounting.
- 1x18W UV-A shatter-proof fluorescent tube.
- Adhesive plate at the rear to catch the insects.
- Lamp and adhesive plate are easily replaceable.
- Maximum range approx. 80m<sup>2</sup>.
- Adhesive plate (310x108mm) included.

code	V	W	mm
270189	230	18	375x140x(H)196
270219	adhesive plate 10 pcs		310x108
270226	replacement lamp	230	18 44x23x220

### INSECT KILLER WITH ADHESIVE PLATE 100M<sup>2</sup>

- Suitable for use in food preparation and serving areas.
- Metal casing including wall mounting.
- 2x15W UV-A shatter-proof fluorescent tubes.
- Adhesive plate at the rear to catch the insects.
- Maximum range approx. 100m<sup>2</sup>.
- Adhesive plate included.

code	V	W	mm
270080	230	30	480x100x(H)285
270073	adhesive plate 10 pcs		395x210
270028	replacement lamp 2 pcs.	230	2x15

HYGIENE

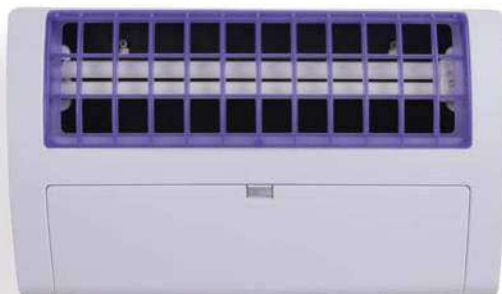

270196



270028



### INSECT KILLER WITH ADHESIVE PLATE 120M<sup>2</sup>

- Suitable for use in food preparation and serving areas.
- ABS fire-resistant casing, back panel of metal, suitable for wall mounting.
- 1x36W UV-A shatter-proof fluorescent tubes.
- Adhesive plate at the rear to catch the insects.
- Lamp and adhesive plate are easily replaceable.
- Maximum range approx. 120m<sup>2</sup>.
- Adhesive plate (390x270mm) included.

code	V	W	mm
270196	230	36	475x80x(H)283
270233	adhesive plate 10 pcs		390x270
270240	replacement lamp	230	36 42x23x410

## INSECT KILLERS FOR OUTDOOR USE



270202



270257

The insects are attracted by the light and sucked into a container by a powerful fan where they will die by dehydration



### INSECT KILLER WATER RESISTANT

- The insects are attracted by the light and sucked into a container by a powerful fan where they will die by dehydration.
- High quality 25W BLB 3U tube produces 100% invisible UV-A light.
- ABS fire-resistant casing.
- IPX4 waterproof, can be used indoor or outdoor.
- Removable collection container, easy to clean.
- Maximum range approx. 300m<sup>2</sup>.
- Chain mounting.

code	V	W	mm
270202	230	30	ø330x(H)570
270257	replacement lamp	230	25 ø50x175

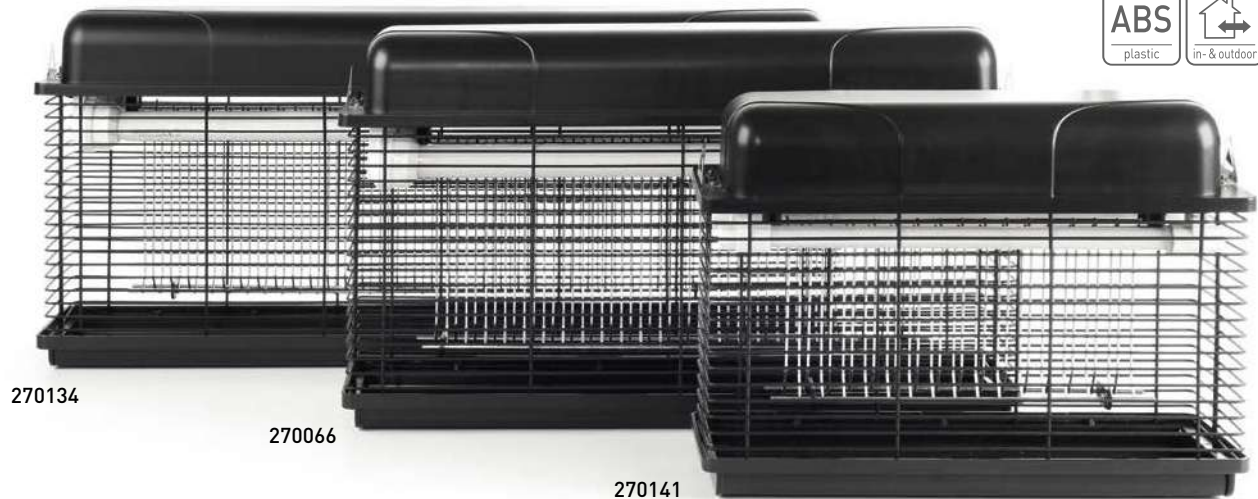

270134

270066

270141



Chain included



Removable collection tray

### INSECT KILLER WATER RESISTANT

- ABS fire proof material for high safety.
- 2x UV-A tube.
- Insects are electrocuted with 2000 V.
- IPX4 waterproof, can be used indoor or outdoor.
- Removable collection tray, easy to clean.
- Chain mounting.

code	V	W	mm
270134	75 m <sup>2</sup>	230	26 360x135x(H)270
270066	100 m <sup>2</sup>	230	40 510x105x(H)315
270141	150 m <sup>2</sup>	230	45 680x135x(H)310

### REPLACEMENT LAMP FOR FLY KILLERS

- UV-A fluorescent tube.

code	V	W	
934159	for 270134 & 270158	230	8
934166	for 270141 & 270172	230	20



934159

**NEW!**



# INSECT KILLERS FOR INDOOR USE

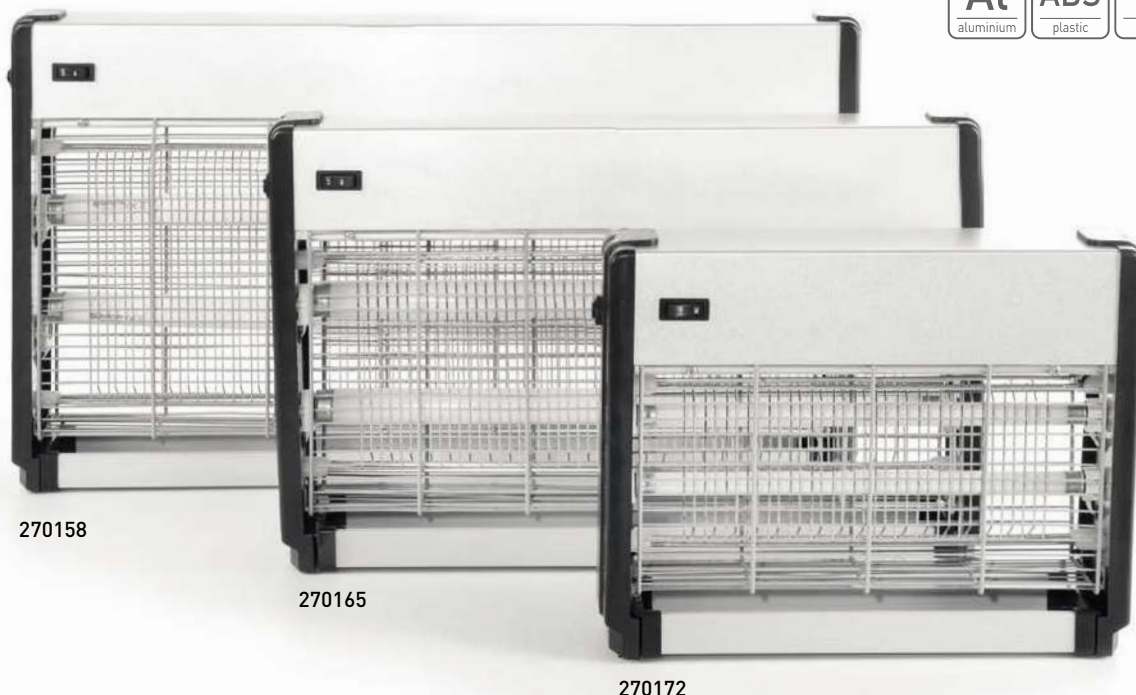

270158

270165

270172

Chain included



Removable collection tray



## HIGH VOLTAGE INSECT KILLER

- For indoor use.
- Body made of special treated aluminum alloy and ABS, fire resistant materials for high safety.
- 2x UV-A tubes.
- Insects are electrocuted with 2000 – 2500 V
- Removable collection tray, easy to clean.
- Can be mounted to ceiling by chain or used free standing.

code		V	W	mm
270158	Coverage: 50 m <sup>2</sup>	230	26	335x90x(H)260
270165	Coverage: 100 m <sup>2</sup>	230	40	485x90x(H)310
270172	Coverage: 150 m <sup>2</sup>	230	45	640x90x(H)360

## REPLACEMENT LAMPS FOR FLY KILLERS

- Set of 2 15W UV-A fluorescent tubes.
- Replacement lamps for Prod. No. 270066/270165.

code	V	W
935286	230	2x15



935286



663950

## WET FLOOR SIGN

- Warning in 5 languages

code	mm
663950	300x(H)615



## WET FLOOR SIGN

- Pyramid shaped.
- Warning in 5 languages.

code	mm
663998	280x280x(H)920



**NEW!**

663998







810316



### WASHBASIN KNEE OPERATED

- Fully made of stainless steel.
- The basin has a diameter of 350 mm and a depth of 123 mm.
- Easy to operate with a knee.
- Connecting materials included.

code	mm
810316	400x400x(H)450



810309



### KITCHEN SINK

- With knee-operated faucet and soap dispenser.
- 1/2" water connection.
- Basin and backsplash made of 18/10 stainless steel.

code	mm
810309	400x335x(H)200/570



281246



### UV STERILIZER

- Perfect for sterilizing knives, capacity for 14 knives.
- Made of stainless steel with plexiglass door.
- Fitted with stainless steel knife holder.
- Sterilizes by means of bactericidal ultraviolet light.
- Equipped with a microswitch to prevent operation while the door is open.
- Integrated timer adjustable up to 60 minutes.

code	V	W	mm
281246	230-240	25	510x160x(H)610



221808

### HAND DRYER

- Electric
- Activation by motion detector
- Fitted with lead and plug
- Impact resistant metal casing in white epoxy finish

code	V	W	mm
221808	230	1500	240x210x(H)265





970515

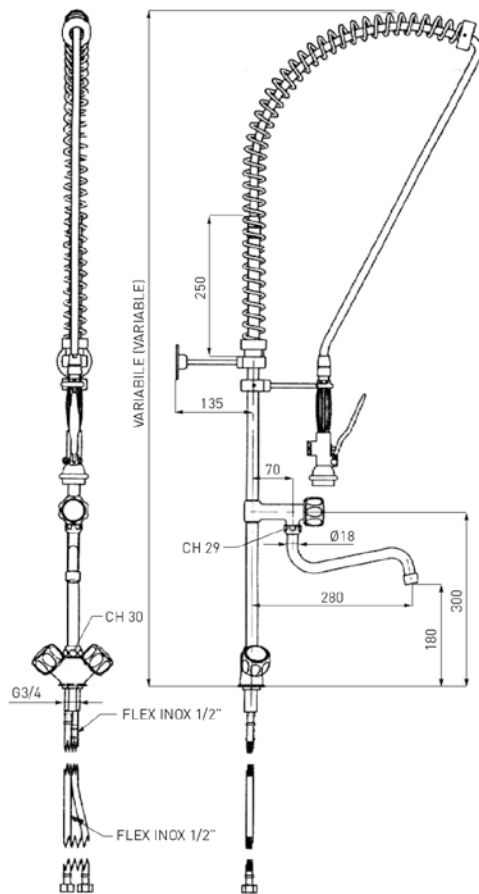

### TAP WITH PULL OUT RINSER

- Single-hole pillar tap.
- Rinser resistant to high pressure water flow.
- Plastic rinser casing.
- Adjustable column support.
- Wall mount (optional shortening).
- Connection hoses: 1/2".
- Table hole required:  $\varnothing$  30 mm.
- Spout reach 280 mm.

code

970515



SELF-ASSEMBLY



970300

## NEW!

### SINGLE PEDESTAL PRE-RINSER

- Single pedestal pillar tap.
- Rinser resistant to high pressure water flow.
- Maximum water flow: 17 L/min. at a pressure of 4 bar.
- Plastic rinser handle.
- Adjustable column support.
- Wall mount (optional shortening).
- Connection hoses: 1/2", 400 mm long each.
- Table hole required:  $\varnothing$  27 mm.

code

970300

S.S.  
stainless steel

**NEW!**



691120

**TRASH BIN 43 L**

- Made of stainless steel.
- With swivel lid.



code	mm
691120	360x360x(H)770



691021

**TRASH BAG HOLDER**

- Frame made of stainless steel.
- Foot-operated clamping mechanism keeps the bag closed.
- 2 caster wheels with brakes.



code	mm
691021	420x580x(H)960

**NEW!**

560044



**CHEF'S HAT - 10 PCS**

- Pleated nonwoven PP material
- Perforated crown
- Adjustable size

code	mm
560044	280x(H)230

**NEW!**

560037



**FORAGE HAT - PAPER - 100 PCS.**

- White with blue strip
- Perforated crown
- Fits all sizes

code	mm
560037	290x(H)100



**CORKSCREWS & BOTTLE OPENERS**



596807



597200



597507

**WAITER'S CORKSCREW**

- Chrome plated, with ABS handle
- 4 functions
- With separate bottle-opener



**WAITER'S CORKSCREW**

- Curved model
- 3 functions



**CORKSCREW**

- Lever model
- Chrome-plated
- With bottle-opener



code	mm
596807	140

code	mm
597200	110

code	mm
597507	170



see movie

**NEW!**



597323



Perfect for uncorking long corks

597316



**WAITER'S CORKSCREW PROFI LINE**

- Made of stainless steel, ABS grip.
- 3 functions.
- Patented lever, spiral for long corks and foil cutter.

**WAITER'S CORKSCREW**

- With metal handle.
- 3 functions.
- With extra kink in lever for long corks.

code	mm
597323	37x130x14

code	mm
597316	120

BAR & COLD DRINKS



**NEW!**



596746



**BAR BLADE**

code	mm
596746	40x2x179



643914



See movie



**BOTTLE OPENER WITH CATCHER BIN**

- This bottle opener is intended to be mounted on the wall.
- Bin can be easily removed to ease emptying.
- Supplied with two screws and wall plugs.

code	mm
643914	135x70x(H)295



**POURERS**

**NEW!**



599372

**FREE-FLOW POURER**

- EVA plastic with chrome-plated nozzle



code	packed per
599372	6



**NEW!**



599464

599471

599488



**FREE-FLOW POURER**

code	model	packed per
599464	Slow flow	6
599471	With flip top	6
599488	Fast flow	6

**NEW!**



599402

599419

599426

599433

**FREE-FLOW POURER**

- EVA plastic

code	model	packed per
599402	Blue	4
599419	Red	4
599426	Transparent	4
599433	Yellow	4

**NEW!**



599440



599457

**FREE-FLOW POURER**

- EVA plastic

code	model	packed per
599440	2 black, 2 white, 2 red	6
599457	2 blue, 2 red, 2 green	6



**ABS**  
plastic



598719

598818



**NON-DRIP BRACKET**

- For bottle height from 240 to 350 mm.

code	type of mounting
598719	shelf mounted
598818	wall mounted



598016

598214

598313

598412

**NON-DRIP POURER**

code	ml
598016	20
598214	35
598313	40
598412	50



599013

599112

599198

599211

**SAN**  
plastic

**BALL MEASURING POURER**

code	ml	packed per
599013	20	2
599112	35	2
599198	40	2
599211	50	2

**NEW!**

BAR & COLD DRINKS



595589

**CHAMPAGNE STOPPER**

- For storing opened bottles.  
- With silicone gasket.

**Cr**  
chrome plated

**SIL**  
silicone

code
595589



see movie



Keep insects out of drinks



595572

**BOTTLE CAP PERFORATOR**

- "Prikit".  
- Perforates bottle caps and cans easily with a  $\varnothing$  5 mm hole.  
- Passing a straw through the hole keeps insects out of the drink.  
- Reduces spillage if a drink is knocked over.

code	packed per
595572	16

**WINE COOLERS AND STANDS**



593806

**WINE COOLER**

- Double-walled stainless steel.
- For use without ice cubes.



**WINE COOLER**

- With ring handles

code	liter
593202	3,3

593202

**WINE COOLER**

- With tulip handles



**WINE COOLER**

- With tulip handles

code	liter	mm
593103	3,5	Ø210x(H)210

593103



code	mm
593806	Ø120x(H)180



593813

**WINE COOLER EPP**

- Made of EPP, highly insulating.
- Stable heavy bottom, unbreakable.
- The temperature of the wine rises at about 1.5°C per hour, keeps wine cool longer than regular steel coolers.

code	mm
593813	Ø142x(H)210



593158

**WINE COOLER**

- Transparent



code	mm
593158	220x185x226



593905

**WINE COOLER TABLE BRACKET**

- Ring Ø185 mm.
- Wine cooler not included.



code	mm
593905	Ø195x(H)510

**WINE COOLER STAND**

- Very compactly packed
- 5-part assembly



code	mm
593608	Ø185x(H)740

593608





471500

**CHAMPAGNE COOLER**



code	liter	mm
471500	13,5	Ø370x(H)230



471524

**CHAMPAGNE COOLER ECONOMIC**



code	liter	mm
471524	9,5	Ø350x(H)230



594704

**ICE BUCKET DOUBLE-WALLED**



code	liter	mm
594704	5	Ø200x(H)230



593165

**PARTY TUB**  
- Transparent  
- Oval



code	mm
593165	470x290x230



594742

**ICE BUCKET WHITE DOUBLE-WALLED**

code	liter	mm
594742	5	Ø190x(H)200
594759	10	Ø292x(H)220



521410

**ALUMINIUM ICE SCOOP**



code	liter	mm
521410	0,17	78x48x215



523520

**ICE CUBE TONGS**  
- Packed per 2.



code	mm
523520	180



**NEW!**



**NEW!**



679012



**ICE CUBE MOULD ASSORTED GEMS**

- Ideal for cocktails, a must have for bar professionals.
- Creates 6 gem-shaped ice cubes.
- Made of durable, food-grade silicone.

code	mm
679012	190x105x(H)30

**NEW!**



679043



**ICE CUBE MOULD SMALL CUBE**

- Ideal for cold drinks, a must have for bar professionals.
- Creates 15 cubes (±3x3x3 cm).
- Made of durable, food grade silicone.

code	mm
679043	190x120x(H)35

**NEW!**



679036



**ICE CUBE MOULD XL CUBE**

- Ideal for whiskey, a must have for bar professionals.
- Creates 6 big (±5x5x5 cm), slow melting ice cubes.
- Made of durable, food grade silicone.

code	mm
679036	170x110x(H)52

**NEW!**



679029



**ICE BALL MOULD WHISKY BALL**

- Ideal for whiskey, a must have for bar professionals.
- Creates 6 big spherical shaped (± ø4,5 cm), slow melting ice cubes.
- Consists of 2 parts with locking ring so the balls can be made without leaking.
- Made of durable, food grade silicone.

code	mm
679029	180x125x(H)50

**NEW!**



679050



**ICE SHOT GLASS MOULD**

- Ideal for serving shots, a must have for bar professionals.
- Creates 6 shot glass shaped ice cubes.
- Made of durable, food grade silicone.

code	mm
679050	125x190x(H)60

**NEW!**



679067



**ICE SHOT GLASS MOULD**

- Ideal for serving shots, a must have for bar professionals.
- Creates 4 shot glass shaped ice cubes.
- Made of durable, food grade silicone.

code	mm
679067	122x122x(H)60

Soft rubber in holder



679005

**ICE CUBE MOULD**

- Professional
- Soft rubber in holder
- Holds 32 ice cubes

code	mm
679005	335x180





**S.S.**  
stainless steel

**ABS**  
plastic



271551



3 ice cube sizes possible



271568



3 ice cube sizes possible

**ICE CUBE MACHINE - KITCHEN LINE 15**

- Tabletop model
- Casing made of stainless steel
- Capacity of 15 kg per 24 hours, buffer stock of 4,5 kg
- 12 cubes per cycle
- No fixed water connection - coolant: R134A
- Choice of 3 ice cube sizes, cubes are formed around cooling rods
- Holds 150 ice cubes

code	V	W	mm
271551	230	160	380x435x(H)431

**ICE CUBE MACHINE - KITCHEN LINE 12**

- Tabletop model
- Casing entirely made of ABS
- Capacity of 12 kg per 24 hours, buffer stock of 3,2 kg
- 9 cubes per cycle
- No fixed water connection - coolant: R600A
- Choice of 3 ice cube sizes, cubes are formed around cooling rods
- Stores 100 ice cubes

code	V	W	mm
271568	230	120	297x367x(H)378



**PP**  
polypropylene

**ICE CUBE MACHINE**

- Stainless steel casing suitable for installation under the counter.
- Can produce up to 35 kg of ice per day and has buffer stock for 15 kg.
- Produces 45 square ice cubes per cycle of 13-16 minute. Cubes need to be separated from each other.
- Comes with supply hose and ice scoop.
- Air-cooled injection system, coolant R134A.

code	V	W	mm
271575	230	300	448x400x(H)798



271575

# NEW!



271773



271797



### BULLET ICE CUBE MAKER

- Makes bullet shaped ice cubes that are partially hollow.
- Housing completely made from stainless steel.
- Can store up to 7 kg. of ice.
- Inlet & outlet hoses and ice scoop included.
- Climate class: N.
- Refrigerant: R290.

code	-	V	W	mm
271773	~26kg/day	230	241	398x546x(H)682
271780	~50kg/day	230	293	398x546x(H)682



### FLAKE ICE MAKER

- Makes flakes of ice, ideal for cocktails, etc.
- Housing completely made from stainless steel.
- Can hold up to 20 kg. of ice.
- Inlet & outlet hoses and ice scoop included.
- Climate class: N.
- Refrigerant: R290.

code	-	V	W	mm
271797	~85kg/day	230	430	548x612x(H)867





## BACK BAR REFRIGERATORS

- Powder coated housing, embossed aluminium chamber, plastic lockable door(s) with toughened glass.
- Forced air cooling with auto-defrost, compressor placed underneath the chamber.

**NEW!**



- Chamber fitted with LED lighting.
- Digital display and temperature control.
- Fitted with 4 adjustable non-slip feet.
- Coolant: R600a.



233900



233917

### BACK BAR REFRIGERATOR SINGLE DOOR 118L

- Single door, with 2 chrome plated shelves.

code	range	V	mm
233900	2°/10°C	230	500x500x(H)900

### BACK BAR REFRIGERATOR SLIDING DOORS 228L

- Double sliding door, with 4 chrome plated shelves.

code	range	V	mm
233917	2°/10°C	230	900x500x(H)900



233924



233931

### BACK BAR REFRIGERATOR SINGLE DOOR 293L

- Single door, with 5 chrome plated shelves.

code	range	V	mm
233924	2°/10°C	230	600x515x(H)1820

### BACK BAR REFRIGERATOR DOUBLE DOORS 458L

- Double sliding doors, with 10 chrome plated shelves.

code	range	V	mm
233931	2°/10°C	230	900x515x(H)1820





## WINE COOLERS DUAL ZONE

**NEW!**



- Dual zone allows to set two different temperatures for the two zones.
- Black housing, borderless glass door fitted with stylish stainless steel handle.
- With lockable self-closing door.
- Forced air cooling with auto-defrost, compressor placed behind the chamber.
- Supplied with wooden shelves.
- With bright LED lighting in the ceiling.
- Digital temperature controller and display. Can be set in Celsius or Fahrenheit
- Fitted with 4 adjustable non-slip feet.
- Climate class: N
- Refrigerant: R600a.



Dual zone



Wooden shelves included



Door can be locked



233221



233245

### WINE COOLER DUAL ZONE 165L

- Suitable for up to 44 bottles of wine.
- Supplied with 5 wooden shelves.

code	range	V	W	mm
233221	4°/20°C	230	130	596x654x(H)855

### WINE COOLER DUAL ZONE 450 L

- Suitable for up to 165 bottles of wine.
- Supplied with 15 wooden shelves.

code	range	V	W	mm
233245	4°/20°C	230	150	596x720x(H)1820





271520

**ICE CRUSHER**

- Large ABS plastic ice chute and brushed stainless steel housing.
- Stainless steel blades and durable grinding mechanism.
- Clear, break resistant container with capacity for 12 cups of crushed ice.
- Crushes up to 12 kilos of ice per hour.
- Not for continuous use.



code	V	W	mm
271520	230	80	170x260x(H)460



271513

**ICE CRUSHER - ELECTRICAL**

- Professional ice crusher perfect for preparing ice for granitas, mojitos, iced coffee and other iced beverages.
- Coated cast aluminium engine housing.
- Microswitch in the closing mechanism.
- Cup, a set of stainless knives.
- Various ice chip sizes.
- Cup capacity 3 L
- Speed: 800 RPM
- Output 120 kg/h
- Weight: 5 kg



code	V	W	mm
271513	230	150	210x380x(H)490



See movie



**ICE CRUSHER**

- Chrome-plated zinc alloy with stainless steel blades.
- Including ice scoop.
- With removable container.

code	mm
695708	160x140x(H)270



695708

### SODA SPLASH BEVERAGE CARBONATING SYSTEM

- The Soda Splash is a simple device in which you can carbonate all kind of beverages like cocktails, syrups, water, wine, etc.
- Making fizzy cocktails is easy and fast, put all the ingredients into the bottle and follow a few simple steps.
- High polished stainless steel bottle, filling head fitted with pressure release button and overpressure release valve.
- Comes with funnel, bottle cap and charge holder.
- Only suitable for cold liquids, not intended for creamy or thick liquids.
- Requires carbon dioxide chargers for use.



code	liter	mm
588567	0,75	ø80x(H)370

Making fizzy cocktails is easy and fast, put all the ingredients into the bottle and follow a few simple steps



588567

### SODA SIPHON

- Stainless steel soda siphon.
- Makes fresh carbonated water in no time.
- Requires carbon dioxide chargers for use.



code	liter	mm
588574	1,0	ø100x(H)320

### SODA CHARGERS

- Contains 8 grams of CO<sub>2</sub>, a single filling of a 1L soda siphon

code	packed per
588406	10



588406



588574





**CENTRIFUGAL JUICE EXTRACTOR**

- For making juice of hard fruits and vegetables.
- Housing, bowl, juicer basket and grating disk made of stainless steel.
- Feeder tube and pusher made of ABS, pulp container and lid made of polypropylene.
- Motor spins the grating disk at 3000rpm.
- Safe to use, will only work if the lid and safety arm are locked into place.
- Not suitable for ice or frozen fruits/vegetables.

code	V	W	mm
221082	230	700	250x410x(H)530



All elements except the body are dishwasher safe

221082





## SLOWJUICER

- Ideal for: fresh juices, mousses, paste and fruit cocktails.
- Suitable for soft (blueberries, raspberries, strawberries) as well as hard fruit and vegetables (beetroot, turnip, ginger) and herbs, grass, sprouts (nettle, wheatgrass, dandelion).
- In comparison to traditional juicers, this device squeezes much more juice and the remaining fruit and vegetable pulp is almost completely dry which proves the exceptional performance of the device.
- The juice squeezing process is similar to mechanical cold-pressing.
- Number of rotations: 45 rpm.
- Reverse function to unblock the auger.
- Strong induction motor assuring high power and durability of the device.
- Very quiet at work: 65 dB.
- Magnetic protection prevents switching on if the head is incorrectly fitted.
- Maximum continuous work time: up to 20 min.



- Large feed chute with mechanism preventing the insertion of hands Ø83 mm (e.g. apples, pears, turnip).
- Small feed chute Ø42 mm with a pusher for long vegetables (e.g. carrots, parsnip, leek).
- Juice spout with a practical and tight cap.
- Inner strainer made of AISI 304 steel.
- Auger, strainer frame and strainer elements made of TRITAN – BPA free.
- Housing with a practical handle made of satin aluminium and ABS.
- Easy to use and clean.
- Weight: 7.2 kg.
- Two polycarbonate containers for pulp and juice, 850 ml each.
- Cleaning brush with nylon bristles.

## SLOWJUICER

code	V	W	mm
221044	230	250	260x175x(H)545

Large feed chute Ø 83 mm with mechanism preventing the insertion of hands (e.g. apples, pears, turnip)



Small feed chute Ø 42 mm with a pusher for long vegetables (e.g. carrots, parsnip, leek)



221044





### CITRUS JUICER ELECTRIC

- Top with lever provides easy and safe operation.
- Removable bowl and cone of stainless steel.
- With splash screen.
- RPM: 980/min.

code	V	W	mm
221099	230	230	280x200x(H)470

221099

Splash screen

Stainless steel bowl

BAR & COLD DRINKS





### CITRUS JUICER ELECTRIC

- Made of rust-resistant material.
- With stainless steel squeeze bowl.
- Including 3 interchangeable ABS cones for small and large citrus fruit.
- ABS sieve.
- Speed 1500 rpm.
- Manually operated by means of on/off switch.
- Including polycarbonate anti-splash cover.
- All elements except the body are dishwasher safe.

code	V	W	mm
221204	230	180	308x218x(H)463



221204



3 cones for different sizes of fruit







224038

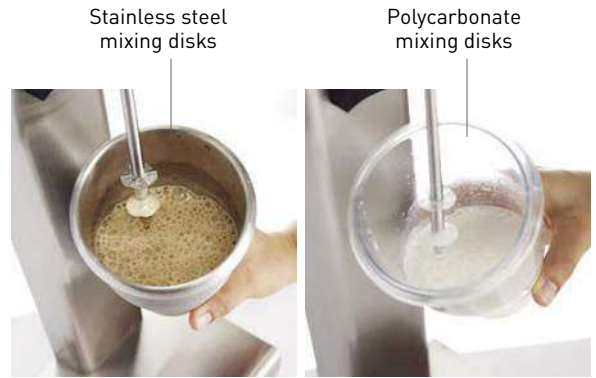

**MILKSHAKER 1 LITER**

- Supplied with 1 stainless steel malt cup, 1 polycarbonate malt cup, 2 stainless steel mixing disks and 4 polycarbonate mixing disks.
- Stainless steel frame.
- Micro switch activates the machine when the cup is placed.
- Powerful motor spins the carbon steel rod at 15000 rpm.
- Capacity of cup: 1000 ml.

code	V	W	mm
224038	230	180	170x170x(H)520
942758		Malt cup stainless steel	
942765		Malt cup polycarbonate	



695906



**CITRUS JUICER**

- Lever model, chrome-plated
- Made of high quality zinc alloy
- With handle for increased stability
- Lever folds back easily using a spring
- Stainless steel juice bowl and cone



code	mm
695906	225x180x(H)510





### CITRUS SQUEEZERS

- Aluminium alloy with powder coating.

code	-	mm
592069	orange (for oranges)	232x91x60
592052	yellow (for lemons)	223x75x45
592045	green (for limes)	203x60x40



557600

557617

557624

557631

557648



### BAR STORERS

- Interchangeable spout and lid.
- For storage, mixing and serving of drinks.
- Upper part removable.

code	-	liter	mm
557600	red	0.8	Ø 90x(H)300
557617	blue	0.8	Ø 90x(H)300
557624	green	0.8	Ø 90x(H)300
557631	brown	0.8	Ø 90x(H)300
557648	yellow	0.8	Ø 90x(H)300





274224



See movie



**SLUSH MACHINE 2X12L**

- Two 12 liter containers with quick dispense tap, the lids are lit.
- Digital temperature controller with cold beverage and slush modes.
- Efficient compressor, in slush mode temperature varies between -7°C and -2°C.
- Containers can be removed to ease cleaning.
- Day and night mode.
- Refrigerant: R404a.
- Drip tray included.

code	liter	V	W	mm
274224	2x12	230	850	470x520x(H)810



425206

**NEW!**



**JUICE DISPENSER 2X12L**

- Two 12 liter containers with quick dispense tap.
- With temperature controller, temperature can be set between 2°C and 8°C.
- Containers can be removed to ease cleaning.
- Refrigerant: R290.
- Drip tray included.

code	liter	V	W	mm
425206	2x12	230	395	430x430x(H)640



### HIGH POWER BLENDER

- This high power blender can prepare anything: fruits, vegetables, cocktails, smoothies, desserts and even crushed ice.
- Comes complete with 2,5L break-resistant jug, pusher and firm lid.
- Detachable jug made of polycarbonate, which can withstand temperatures of -40°C up to 90°C.
- Replaceable knife made of stainless steel, housing and lid made of ABS plastic.
- Hi-speed motor with variable speed and pulse function drives the knife from 8350 RPM up to 24800 RPM (without load).
- Equipped with over-heat and over-current protection.

code	V	W	mm
230718	230	1680	270x250x(H)550

Comes complete with 2,5L break-resistant jug, pusher and firm lid



Very powerful, can even crush ice



230718



### BLENDER JAR BPA FREE

- Replacement jar for blender 230718/230695/230688, made of BPA-free Tritan copolyester.
- The jar is fitted with the blender blades and is supplied with a lid.



933688



### BLENDER JAR

- Replacement jar for blender 230718, made of polycarbonate.
- The jar is fitted with the blender blades and is supplied with a lid.



942642



### BLENDER JAR

- Replacement jar for blender 230718/230695/230688.
- 2,5L break-resistant polycarbonate jug, firm lid made of PBT and a small polycarbonate lid cover.
- The jar is fitted with the blender blades made of stainless steel knife with titanium coating.



943489

**NEW!**

code	mm
933688	200x170x(H)360

code	mm
942642	200x170x(H)360

code	mm
943489	200x170x(H)360







**BLENDER WITH NOISE COVER**

- This blender can prepare anything: fruits, vegetables, cocktails, smoothies, desserts and even crushed ice.
- Replaceable stainless steel knife with titanium coating.
- Manual control panel power setting knob and a pulse switch.
- Noise cover made of polycarbonate, the blender only works when the cover is completely closed.
- Comes with 2,5L break-resistant polycarbonate jug, firm lid made of PBT and a small polycarbonate lid cover.
- Detachable jug can withstand temperatures of -40°C up to 90°C.
- Hi-speed motor with variable speed and pulse function drives the knife from 8350 RPM up to 24800 RPM (without load).
- Equipped with over-heat and over-current protection.

code	V	W	mm
230688	230	1680	252x258x(H)547



1 2 3

- 1 - Power switch 0N/OFF
- 2 - Speed dial (Low to High)
- 3 - Pulse button



See movie

230688

BAR & COLD DRINKS

Break-resistant polycarbonate jug



Stainless steel knife with titanium coating



Solid construction of the gear







### DIGITAL BLENDER WITH NOISE COVER

- This blender can prepare anything: fruits, vegetables, cocktails, smoothies, desserts and even crushed ice.
- Replaceable stainless steel knife with titanium coating.
- Digital control panel has touch control for three power settings, three time settings and a pulse function.
- Noise cover made of polycarbonate, for safety the blender only works when the cover is completely closed.
- Comes with 2,5L break-resistant polycarbonate jug, firm lid made of PBT and a small polycarbonate lid cover.
- Detachable jug can withstand temperatures of -40°C up to 90°C.
- Hi-speed motor with variable speed and pulse function drives the knife from 8350 RPM up to 24800 RPM (without load).
- Equipped with over-heat and over-current protection.

code	V	W	mm
230695	230	1680	252x258x(H)547



230695



1 2 3 4 5

- 1 - switch ON/STANDBY
- 2 - Speed control: Low/Medium/High
- 3 - Digital Control Display
- 4 - Timer
- 5 - Pulse Button



See movie

Noise cover reduces sound significantly

Anti-slip base

Durable metal gear socket





593042



593066

**BOSTON SHAKER**



code	-	liter
593042	shaker	0,8
593066	mixing glass	0,45



593004

**COCKTAIL SHAKER**  
- 3-piece



code	liter	mm
593004	0,75	Ø80x(H)240



593035

**COCKTAIL SHAKER CONICAL**



code	liter	mm
593035	0,75	Ø90x(H)255



35 ml

596715

25 ml

**JIGGER**

- 2 sides: 25 ml and 35 ml



code	mm
596715	Ø40x(H)75



50 ml

596722

25 ml

**JIGGER**

- 2 sides: 25 ml and 50 ml



code	mm
596722	Ø40x(H)85



593097

**BAR SPOON**



code	mm
593097	27x27x266



596739

**MUDDLER**



code	mm
596739	34x34x207



596753

**STRAINER**



code	mm
596753	82x28x165



596760

**BAR CADDY**

- 6 compartments for organizing straws, napkins, stirrers etc.
- Container for napkins 130x130 mm.



code	mm
596760	240x145x(H)105



596777

**3-TIER GLASS RIMMER**

- For decorating the edge of glasses.
- Three tiers marked with lime juice, salt, sugar.
- Sponge for lime juice to prevent spilling.



code	mm
596777	200x160x(H)75



552131

**INGREDIENT BOX**

- Black ABS with transparent polycarbonate lid.
- Including 5 polypropylene storage containers.



code	mm
552131	495x160x(H)100



552100

**INGREDIENT BOX**

- Stainless steel with transparent polypropylene lid
- Including 5 white polypropylene storage containers



code	mm
552100	375x140x(H)90

**CUTTING BOARD WITH HANDLE**

- Made of polyethylene HDPE.
- Both sides suitable for cutting.



code	mm	colour
826348	250x150x(H)10	white
826478	250x150x(H)10	black
826355	300x200x(H)10	white
826485	300x200x(H)10	black



826348

826355

**NEW!**







552681

### GLASS BRUSH ROUND

- Aluminium with nylon brush.
- Bottom plate fitted with 4 suction pads.



code	mm
552681	Ø150x(H)190



696002

### GLASS BRUSH STANDARD

- Polypropylene with 3 nylon brushes.
- Bottom plate fitted with 4 suction pads.



code	mm
696002	190x100x(H)180



696040

### GLASS BRUSH HIGH

- Polypropylene with 3 nylon brushes.
- Bottom plate fitted with 4 suction pads.



code	mm
696040	190x100x(H)180/250/180



597972

597965

### RUBBER BAR MAT

code	mm
597965	605x85x(H)15
597972	495x160x(H)10

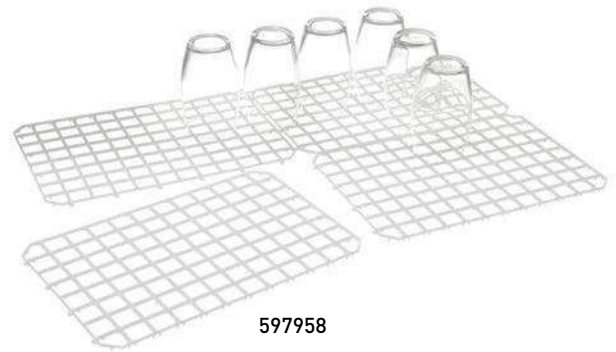

597958

### DRAINAGE MAT

- Connectable
- White polypropylene
- HACCP compliant



code	packed per	mm
597958	5	313x209





see movie



598955



598962

### TABLE BEER TAP

- Plexiglas

- With strong non-drip tap



code	liter	mm
598955	3	Ø100x(H)815
598962	5	Ø100x(H)1150



696200

### BEER GLASS CARRIER

- Holds 12 glasses, holes Ø 55 mm



code	mm
696200	Ø315



565360

### BEER SKIMMER

- White



code	packed per	mm
565360	6	235x26

### COIN TOKENS



code	colour	packed per	Ø mm
665121	blue	100	25.09
665138	green	100	25.09
665145	red	100	25.09
665152	white	100	25.09
665169	black	100	25.09
665381	yellow	100	25.09



**NEW!****NEW!**

208632

**PALM TAMPER ADJUSTABLE**

- Suitable for most portafilters.
- Pre-tamper made of stainless steel, handle made of black aluminium.
- The depth is adjustable.

code	mm
208632	Ø58x(H)35



208625

**COFFEE TAMPER WITH SPRING**

- Used to compact coffee, suitable for most portafilters.
- Tamper made of stainless steel with spring.
- Black aluminium handle.

code	mm
208625	Ø58x(H)105



208731

**COFFEE TAMPER**

- Used to compact coffee, suitable for most espresso machines.
- Tamper made of stainless steel.
- Wooden painted handle.
- Weight: 380 g.

code	mm
208731	Ø58x(H)95

**NEW!****NEW!****NEW!**

208670

**TAMPING MAT**

- Made of silicone, with recess for placing a portafilter during tamping.
- With a socket to place the tamper in.

code	mm
208670	150x100x(H)45



208649

**TAMPING MAT DOUBLE**

- Made of silicone, with recess for placing 2 portafilters during tamping.
- With two sockets to place the tampers in.

code	mm
208649	205x150x(H)45



208687

**TAMPING STAND**

- With recess for placing a portafilter during tamping.
- With a socket to place the tamper in.

code	mm
208687	110x170x(H)65



**NEW!**



208694

**KNOCK BOX RECTANGULAR**

- Drawer model made from carbon steel
- Fitted with removable knock bar and perforated top.

code	mm
208694	350x250x(H)90

**NEW!**



208335



**KNOCK BOX GN**

- Made from stainless steel.
- Removable knock bar fitted with silicone sleeve.

code	-	mm
208335	GN 1/6	176x162x(H)100
208342	GN 1/4	265x162x(H)100

**NEW!**



208380



**KNOCK BOX IN WOODEN FRAME**

- Frame made from dark wood, with a stainless steel GN 1/4 knock box.
- Removable knock bar fitted with silicone sleeve.

code	mm
208380	275x175x(H)120



271247



**MILK FROTHING THERMOMETER**

- With clip to fasten the thermometer to the milk jug.
- Green marking indicates the ideal milk temperature for cappuccino etc.
- Temperature range -10 to 110°C.
- Gradation 1°C.
- Stainless steel probe with protective cover.
- Easy to read.

code	range	mm
271247	-10/110°C	Ø44x140

**NEW!**



208618



**ROUND KNOCK BOX**

- Made from stainless steel.
- Fitted with removable knock bar.

code	mm
208618	153x185x(H)165



208724

**GROUP HEAD CLEANING BRUSH**

- Easily brush coffee residue from the group head and portafilter of espresso machines.
- Tough brush made of nylon.
- Measuring spoon for cleaning agents.
- Splash screen keeps the handle dry.
- Set of 2 pcs.



code	mm
208724	225



428245



**MULTI RACK**

- 3 Layers for holding cups and bags of condiments.
- Polished stainless steel stand with three 1 liter bowls.

code	mm
428245	190x240x(H)410

**NEW!**



208304

**COFFEE MACHINE KITCHEN LINE**

- Top and bottom hotplate, indicator light
- Fast filtering system with flow-through element - 1.8 litres in 5 minutes
- Continuous temperature of 93 - 96°C
- Casing and filter holder made of stainless steel
- 2 x 1.8 l decanters and 50 (110/250) filters are included



code	W	V	mm
208304	2100	230	200x385x(H)430



208533



**COFFEE MACHINE PROFI LINE**

- Makes a can of coffee in about 6 minutes.
- Design casing made of polypropylene with black rubber coating.
- With 1.8 liter glass decanter, polypropylene filter holder and lid.
- With 2 separately operated warming plates.
- With indicator light that shows when the coffee is ready.
- Suitable for 110/250 filters.

code	W	V	mm
208533	2020	230	204x380x(H)425

HOT DRINKS



445907

**DECANTER**

- Toughened glass with polypropylene handle and lid.



code	liter	mm
445907	1,8	Ø160x(H)185



208656

**COFFEE FILTERS Ø 25 CM**

- Unbleached
- For i.e. Hendi, Bravor en Animo coffee machines
- Diameter of the entire filter - 250 mm
- Bottom diameter of the filter - 110 mm

code		packed per	mm
208656	for e.g. Hendi, Bravor & Animo	1000	Ø250x(H)70



### PERCOLATOR SINGLE WALLED

- Single-walled stainless steel housing and lid with safe "Twist-lock" system.
- Inner filter for coarse ground coffee made of stainless steel, use of paper filters is recommended.
- Fitted with cool-touch grips, cover handle and anti-drip spout, all made of polypropylene.
- Clear level indicator in liters,
- Maximum cup height: 110mm (without drip tray).
- Reaches up to 96°C during coffee brewing, keeps the temperature at 90°C ( $\pm 5^\circ\text{C}$ ) afterwards.
- With silicone protected power switch and indicator lights for heating, keep warm and the need of descaling.
- Scale-protected heating element under the tank with overheat protection.
- Drip tray and measuring cup included.

**NEW!**



211267

code	liter	V	W	mm
211267	11	230	1650	350x350x(H)445

With non-drip tap



Twist-lock lid



## PERCOLATORS DOUBLE-WALLED

- Insulated double-wall polished stainless steel structure reduces heat loss through conduction, convection and radiation
- Up to 20% lower energy consumption compared to similar single-walled percolators
- Body and tank made of stainless steel
- Welded stainless steel handles with silicone grip
- Anti-drip tap
- Glass gauge
- Descaling indicator
- Dripping tray with stainless steel grid



211106

211205

211304

### PERCOLATOR DOUBLE WALLED

code	liter	V	W	mm
211106	6	230	1500	Ø241x(H)480
211205	10	230	1500	Ø288x(H)530
211304	15	230	1500	Ø288x(H)602

HOT DRINKS

Double walled - up to 20% lower energy consumption



Built-in filter for coarsely ground coffee



Easily removable dripping tray



## PERCOLATORS SINGLE-WALLED



- Single walled stainless steel body.
- Filter pan has built-in filter for coarsely ground coffee, filter paper not needed.
- The percolator keeps the coffee at serving temperature after brewing.
- With graduated glass, non-drip tap and fitted with automatic reset.
- The indicator light signals the end of the brewing process and if descaling is needed.



208007

208106

208205

### PERCOLATOR

code	liter	V	W	mm
208007	6	230	1500	336x310x(H)465
208106	10	230	1500	384x355x(H)530
208205	15	230	1500	384x355x(H)600

With graduated glass



With non-drip tap



Built-in filter for coarsely ground coffee



## HOT DRINKS BOILERS DOUBLE-WALLED



- Insulated double-wall polished stainless steel structure reduces heat loss through conduction, convection and radiation
- Thermostatic temperature control adjustable up to 110°C
- Up to 20% reduction in energy consumption compared to similar single-walled boilers
- Body and tank made of stainless steel
- Maintenance-free heating element under the tank
- Parts can be easily disassembled to facilitate cleaning
- Welded stainless steel handles with silicone grip
- Anti-drip tap
- Glass water gauge
- Descaling indicator
- Dripping tray with stainless steel grid
- Not suitable for chocolate milk



211403



211502

### HOT DRINKS BOILER DOUBLE-WALLED

code	liter	V	W	mm
211403	9,0	230	2200	Ø241x(H)480
211502	18,0	230	2200	Ø288x(H)602

Double walled - up to 20% lower energy consumption

Maintenance-free heating element under the tank

Easily removable dripping tray





## HOT DRINKS BOILER

- Single-walled.
- Ideal for mulled wine and boiling water for tea.
- Time to boiling  $\pm$  50 min.
- Maximum temperature 94-99°C.
- Protected against boiling dry.
- Not suitable for hot chocolate.



Heating element under the tank



209882



209899

### HOT DRINKS BOILER

code	liter	V	W	mm
209882	10	230	2200	336x221x(H)474
209899	20	230	2200	384x268x(H)602

With graduated glass



With non-drip tap



Heating element under the tank





**NEW!**

240700



**HOT DRINKS BOILER**

- Kettle made from stainless steel.
- Fitted with polypropylene insulated handles and non-drip tap.
- Thermostat adjustable up to 110°C.
- Ideal for mulled wine or hot water.
- Time needed for boiling ± 75 min.
- Not suitable for chocolate milk.

code	liter	V	W	mm
240700	28	230	2500	447x441x(H)485



240601



**HOT DRINKS BOILER**

- Kettle made from enamelled stainless steel.
- Fitted with polypropylene insulated handles and non-drip tap.
- Thermostat adjustable up to 110°C.
- Ideal for mulled wine or hot water.
- Time needed for boiling ± 75 min.
- Not suitable for chocolate milk.

code	liter	V	W	mm
240601	28	230	2500	447x441x(H)485



With name card holder

209905



**HOT DRINKS BOILER**

- Single-walled
- With polypropylene non-drip tap
- Fitted with automatic reset
- Operates automatically and keeps drinks at serving temperature
- Cleaning indicator
- Temperature adjustable up to 110°C
- Not suitable for hot chocolate
- Suitable for mulled wine
- Reversible lid can be used as tray and to keep the glasses/ cups warm

code	liter	V	W	mm
209905	30	230	2200	Ø520x(H)500



**NEW!**

211243



**HOT DRINKS BOILER**

- Single-walled brushed stainless steel housing and lid with lock.
- Ideal for mulled wine and boiling water for tea, operates automatically and keeps drinks at serving temperature.
- Temperature adjustable up to 110°C.
- Time needed for boiling ± 45 min.
- Protected against boiling dry.
- With external water gauge and polypropylene non-drip tap.
- Not suitable for hot chocolate.

code	liter	V	W	mm
211243	6,8	230	950	320x310x(H)425
211250	12	230	950	320x290x(H)580





Bain-Marie heating system prevents hot chocolate from being burned to the bottom

274125



See movie



274149

### HOT CHOCOLATE DISPENSER

- Bain-Marie heating system prevents hot chocolate from being burned to the bottom.
- Bottom of the container is made of stainless steel.
- Side walls are made of Polycarbonate.
- Drip tray with float indicator warning when full.
- Protection against overheating.
- Continuous stirring guarantees homogeneous consistency of chocolate.
- Special anti-drip tap.
- Temperature range: 65 to 85°C.
- Required temperature of environment: 10 to 32°C.

code	liter	V	W	mm
274125	5	230	1006	410x280x(H)465
274149	10	230	1006	410x280x(H)580



209998

Internal maximum water level indicator



209981



External water level indicator

### ELECTRIC KETTLE - 4,2 L

- Housing and heating element made of stainless steel.
- Handle, lid and base made of polypropylene.
- Concealed heating element protected against scale which extends the lifetime of the heater and the entire kettle.
- Indicator light informs that the heater is on.
- Internal maximum water level indicator.
- Automatic switch-off after boiling.
- Double dry-boil protection.

code	liter	V	W	mm
209998	4,2	230	2000	340x234x(H)290

### ELECTRIC KETTLE - 1,8 L

- Housing and heating element made of 304 stainless steel.
- Handle, lid and base made of polypropylene.
- 360-degree swivel base.
- Concealed heating element protected against scale which extends the lifetime of the heater and the entire kettle.
- Indicator light informs that the heater is on.
- External water level indicator.
- Internal maximum water level indicator.
- Automatic switch-off after boiling.
- Double dry-boil protection.
- Only suitable for boiling water, boiling other liquids will damage the appliance.

code	liter	V	W	mm
209981	1,8	230	1800	221x163x(H)249





# PROFI LINE



TABLEWARE





**PROFI LINE**

- Elegant yet sturdy.
- Hand polished, high gloss mirror finish.

18/0  
stainless steel



code				length (mm)
764404	1	Table knife	set of 6	225
764411	2	Table fork	set of 6	205
764428	3	Tablespoon	set of 6	205
764435	4	Dessert knife	set of 6	205
764442	5	Dessert fork	set of 6	186
764459	6	Dessert spoon	set of 6	186
764466	7	Cake fork	set of 12	136

code				length (mm)
764473	8	Coffee spoon	set of 12	111
764480	9	Tea spoon	set of 12	138
764497	10	Ice spoon	set of 12	135
764503	11	Sundae spoon	set of 6	198
764510	12	Butter knife	set of 12	158
764527	13	Steak knife	set of 6	215





## KITCHEN LINE

- Hand polished mirror finish.

18/0  
stainless steel

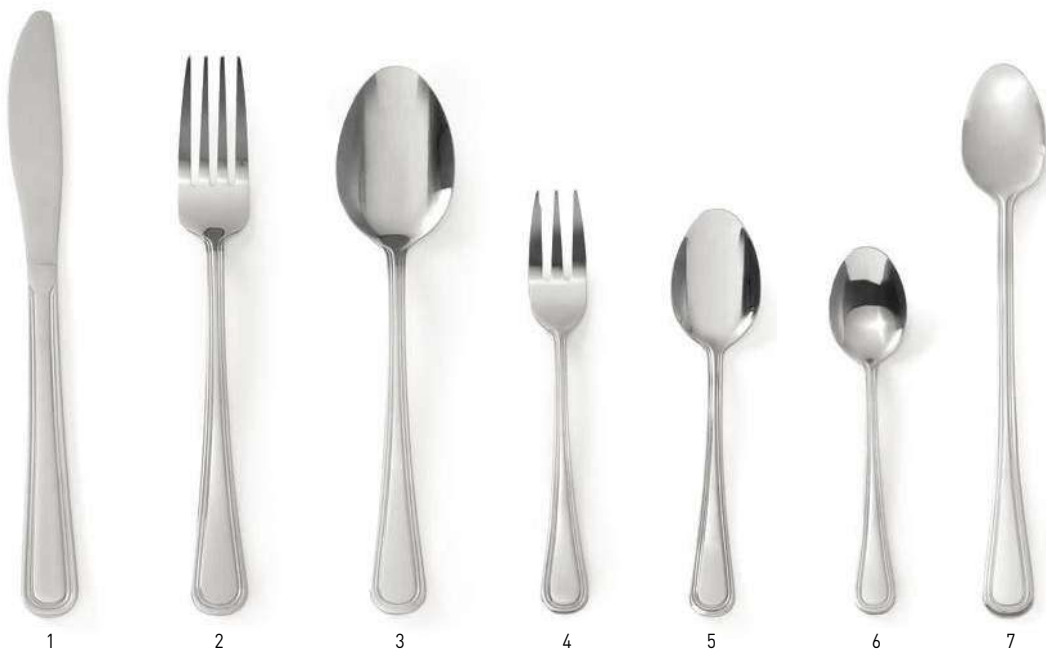

1

2

3

4

5

6

7

code			length (mm)
764206	1 Table knife	set of 6	215
764213	2 Table fork	set of 6	197
764220	3 Tablespoon	set of 6	197
764237	4 Cake fork	set of 12	150
764244	5 Tea spoon	set of 12	146
764251	6 Coffee spoon	set of 12	131
764268	7 Sorbet spoon	set of 6	198





**BUDGET LINE**

- Machine polished



**18/0**  
stainless steel



1                      2                      3                      4                      5                      6                      7

code			length (mm)
764039	1	Table spoon	set of 12 198
764022	2	Table fork	set of 12 198
764015	3	Table knife	set of 12 214
764084	4	Tea spoon	set of 24 138
764091	5	Coffee spoon	set of 24 115
764077	6	Cake fork	set of 24 148
764138	7	Sorbet spoon	set of 12 214







**STEAK CUTLERY**

**ABS** plastic **S.S.** stainless steel



781449



781432



781456

**STEAK KNIFE**

- Stainless steel with ABS handle.

code	packed per	blade/knife length (mm)
781449	6	215

**STEAK FORK**

- Stainless steel with ABS handle.

code	packed per	blade/knife length (mm)
781432	6	200

**STEAK KNIFE XL**

- Stainless steel with ABS handle.

code	packed per	blade/knife length (mm)
781456	6	250







403709

**SET LOBSTER FORKS AND TONGS**

- 4 stainless steel forks
- 1 chrome-plated tongs



code	length (mm)
403709	205



403716

**LOBSTER FORKS**



code	packed per	length (mm)
403716	6	205



402221

**SNAIL FORK**



code	packed per	length (mm)
402221	6	130



402528

**SNAIL TONGS**  
- Squeeze model



code	packed per	length (mm)
402528	2	170



402023

**SNAIL DISH**  
- For 6 snails



code	packed per	ØxH mm
402023	3	150x20



# KARIZMA



TABLEWARE



## KARIZMA

- White hotel porcelain
- Strengthened edges, high quality glazing
- High impact and wear resistance
- 10 years supply guarantee



### FLAT PLATE

code	mm
795101	Ø160
795309	Ø200
795507	Ø240
795705	Ø280
795903	Ø320



### DEEP PLATE

code	mm
794500	Ø300



### OVAL DISH

code	mm
796306	290x200
796405	340x235



### SALAD BOWL

code	mm
796603	Ø150
796702	Ø190
796801	Ø250



### SOUP BOWL

code	ml	mm
798805	soup bowl	380
798904	saucer	Ø180



### CUP AND SAUCER

code	ml	mm
798010	mocha cup	90
798034	saucer	Ø125
798164	coffee cup	170
798249	cappuccino cup	230
798171	saucer for coffee- and cappuccino cups	Ø149





# FLORA





## FLORA

- White hotel porcelain
- Strengthened edges, high quality glazing
- High impact and wear resistance
- 10 years supply guarantee



### FLAT PLATE

code	mm
787007	Ø160
787014	Ø200
787021	Ø255
787038	Ø270
787045	Ø300



### DEEP PLATE

code	mm
787052	Ø235



### OVAL DISH

code	mm
787069	280x180
787076	330x225



### SALAD BOWL

code	ml	mm
787083	250	Ø145x(H)45
787090	1000	Ø230x(H)65



### SOUP BOWL

code	ml	mm
787267	bowl	250
787182	saucer	Ø158



### CUP AND SAUCER

code		ml	mm
787113	mocha cup	120	
787120	saucer		Ø130
787144	coffee cup	180	
787151	saucer		Ø138
787175	cappuccino cup	250	



# SATURN



TABLEWARE



## SATURN

- White hotel porcelain.
- Strengthened edges, high quality glazing.
- High impact and wear resistance.
- 10 years supply guarantee.



### FLAT PLATE

code	mm
794319	Ø 200
794326	Ø 240
794333	Ø 260
794340	Ø 280
794357	Ø 300
794364	Ø 320



### DEEP PLATE

code	mm
794395	Ø 220
794517	Ø 300



### OVAL DISH

code	mm
794371	290x200
794388	340x240



### SALAD BOWL

code	mm
794463	Ø 150
794524	Ø 190
794470	Ø 250



### SOUP BOWL AND SAUCER

code		ml	mm
794449	bowl	380	
794456	saucer		Ø190



### CUP AND SAUCER

code		ml	mm
794425	mocha cup	90	
794432	saucer		Ø125
794401	coffe cup	170	
794418	saucer		Ø150
794487	cappuccino cup	230	



### MUG

code	ml
794531	300





# GOURMET





## GOURMET

- Hotel porcelain
- Strengthened edges, high quality glazing
- High impact and wear resistance
- 10 years supply guarantee



### FLAT PLATE

code	mm
780008	Ø 190
780015	Ø 210
780022	Ø 230
780039	Ø 270
780046	Ø 290
780107	Ø 320



### DEEP PLATE

code	mm
780053	Ø 240



### PASTA PLATE

code	mm
780060	Ø 270



### OVAL DISH

code	mm
780077	240x170
780084	310x220
780091	360x260



### SALAD BOWL

code	ml	mm
780114	250	Ø 130x(H)40
780121	500	Ø 160x(H)60
780138	1200	Ø 230x(H)70
780145	2500	Ø 250x(H)95



### SOUP BOWL

code	ml
780152	350
780169	saucer



### CUP AND SAUCER

code	ml	mm
780176	cup	100
780183	saucer	Ø115
780190	cup	250
780206	saucer	Ø160



# DELTA

TABLEWARE



## DELTA

- White hotel porcelain.
- Strengthened edges, high quality glazing.
- High impact and wear resistance.
- 10 years supply guarantee.



### FLAT PLATE

code	mm
794050	Ø 160
794067	Ø 200
794074	Ø 240
794081	Ø 270
794098	Ø 300



### DEEP PLATE

code	mm
799420	Ø 230



### PASTA PLATE

code	mm
799406	Ø 260
799413	Ø 300



### OVAL DISH

code	mm
799437	290x200
799444	340x240



### SALAD BOWL

code	mm
799451	Ø 120
799468	Ø 140
799475	Ø 230
799482	Ø 270



### SOUP BOWL

code	ml	mm
799383	380	160x(H)55
799390	saucer	Ø 170



### CUP AND SAUCER

code	ml	mm
799161	cup	90
799178	saucer	Ø83
799147	cup	230
799154	saucer	Ø115





## PRESENTATION PLATES AND BOWLS

- Special, toughest porcelain type available on the market.
- High-impact and wear resistance and still relatively light-weight.
- Cream white porcelain.

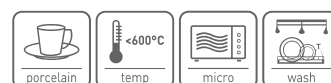

785645



785669

### GARNISH BOWL SLANTED

code	mm
785645	170x163x(H)134
785652	138x138x(H)118

### BOWL

code	mm
785669	280x190x(H)120
785676	235x160x(H)98
785683	180x125x(H)80
785690	140x102x(H)65

## LIONHEAD

- Special, toughest porcelain type available on the market
- High-impact and wear resistance and still relatively light-weight
- Shining white



784730



784778



784754

### SOUP BOWL

code	ml	mm
784778	125	Ø90x(H)60
784761	250	Ø120x(H)78
784754	500	Ø138x(H)95
784747	1000	Ø175x(H)120
784730	2000	Ø215x(H)155



### PLATE TORRO

- Rectangular

code	mm
783658	360x240x(H)30



### PLATE BARK

- Rectangular

code	mm
785546	218x105x(H)23
785553	352x146x(H)40



### BOWL VANILLA

code	mm
785560	225x111x(H)62
785577	290x136x(H)80



## OVEN DISHES WHITE PORCELAIN

- Special porcelain type, toughest type available.
- Thermal shock resistant, can withstand extreme temperature changes.
- High-impact and wear resistance and still relatively light-weight.
- Extremely pure and brilliant white.

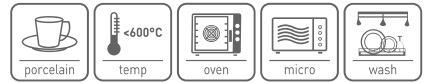

### TAPAS DISH OVAL

code	mm
784006	165x105x(H)30
784013	215x140x(H)35
784020	270x180x(H)40

### TAPAS DISH RECTANGULAR

code	mm
784105	100x140x(H)45
784112	120x190x(H)50
784129	185x260x(H)55



786321



786352

### RUSTICA OVEN DISH OVAL

code	mm
786321	220x130x(H)40
786338	245x145x(H)55
786345	340x205x(H)70

### RUSTICA OVEN DISH SQUARE

code	mm
786352	165x165x(H)70



786369



786307

### RUSTICA OVEN DISH RECTANGULAR

code	mm
786369	280x185x(H)65
786376	330x225x(H)70
786383	375x260x(H)75

### RUSTICA OVEN DISH ROUND

code	mm
786307	Ø100x(H)50

## OVEN DISHES CREAM PORCELAIN

- Special porcelain type, toughest type available.
- Thermal shock resistant, can withstand extreme temperature changes.
- High-impact and wear resistance and still relatively light-weight.
- Cream white.

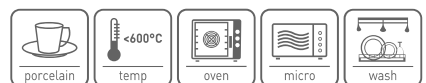

### OVEN DISH ROUND

code	mm
785904	185x152x(H)40



785904



CHILDREN



786499

**CHILDREN'S PLATE "BEAR"**

- Ø190 mm without ears

code	mm
786499	Ø265



786239

**ICE CREAM BOWL CLOWN**

code	mm
786239	226x145x(H)37



786451

**MILK JUG**

- Shining white  
- Special, toughest porcelain type available on the market



code	packed per	liter
786451	2	0,08



786437

**GRAVY BOAT**

- Shining white  
- Special, toughest porcelain type available on the market



code	mm
786437	180x55x(H)130



786413

**CONDIMENT SET**

- 2-piece set: salt, pepper



code	mm
786413	pepper & salt Ø42x(H)80



786420

**CONDIMENT SET**

- 3 piece set: salt, pepper, toothpick holder



code	mm
786420	pepper, salt & toothpick 125x54x(H)90



## TAPASMINI

- Special, toughest porcelain type available on the market.
- High-impact and wear resistance and still relatively light-weight.
- Shining white.



784426



784327



784365

## TAPAS DISH PLATO

code	packed per	mm
784426	6	Ø100x(H)25

## TAPAS DISH CUADRADO

code	packed per	mm
784327	6	80x80x(H)35

## TAPAS DISH REDONDO

code	packed per	mm
784365	6	Ø75x(H)30



784433



784334

## TAPAS DISH LEON

code	packed per	ml	mm
784433	6	50	Ø55x(H)45

## TAPAS DISH CONCHA

code	packed per	mm
784334	6	90x50x(H)20



784419



784396

## TAPAS DISH CUADRADO

code	packed per	mm
784419	6	59x59x(H)37

## TAPAS DISH TRIANGOLO

code	packed per	mm
784396	6	100x100x(H)25



784389



784372



785324

## TAPAS DISH CACEROLE

code	packed per	mm
784389	6	Ø60x(H)25

## TAPAS DISH HUEVO

code	packed per	mm
784372	6	Ø65x(H)15

## TAPAS DISH CUCHARA

code	packed per	mm
785324	6	133x43x(H)26







785645

### GARNISH BOWL SLANTED

code	mm
785645	170x163x(H)134
785652	138x138x(H)118



426425



426432



426449



426456



### DEEP FRYING BASKET MINIATURES

code	mm
426425	100x80x(H)70
426432	120x100x(H)80
426449	Ø90x(H)90
426456	275x130x(H)45







630907

**CHIPS BAG HOLDER**

code	mm
630907	Ø95/110x(H)175



630914

**CHIPS BAG HOLDER**

- Black wire frame, with room for a saus bowl.
- Melamine ramekin 80 ml fits perfectly [561713], not included.

code	mm
630914	210x110x(H)172



630921

**CHIPS BAGS HOLDER**

- Black wire frame, fits 3 chips bags.

code	mm
630921	270x270x(H)280



678138



678107

**GREASEPROOF PAPER**

- Packed per 500 sheets.

code	colour	mm
678107	newspaper print	250x350
678114	plain	250x350
678121	newspaper print	200x250
678138	plain	250x200



## ENAMELLED

- Enamelled tableware has made a comeback.
- White enamelled steel with a nice blue border.
- High quality enamel.
- Abrasion resistant.



621202



621226



621257

### BOWL RECTANGULAR

- Dishes and desserts can be prepared in the bowl.

code	mm
621202	175x130
621219	215x160

### FLAT PLATE

code	mm
621226	Ø200
621233	Ø240

### DEEP PLATE

code	mm
621240	Ø180
621257	Ø200
621264	Ø220
621271	Ø240



621288

### SALAD BOWL

code	mm
621288	Ø160



621295

### MUG

code	ml	mm
621295	360	Ø90x(H)80
621301	520	Ø100x(H)90



621318

### CUP

code	ml	mm
621318	120	Ø70x(H)50



621332

### TUMBLER

code	ml	mm
621325	300	Ø90x(H)90
621332	400	Ø90x(H)120

### BUCKET WITH HANDLE **NEW!**

code	mm
621349	Ø160x(H)140
621356	Ø220x(H)186



621349



320

HENDI







625804



625705

### SOUP & GRAVY PAN - WITH LID

- Enamelled
- Flanged stainless steel rim
- Low lid

code		liter	mm
625804	blue	0,3	Ø120x(H)95
625705	black	0,6	Ø135x(H)103



622704



622728

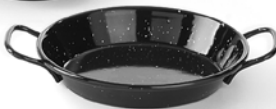

622742

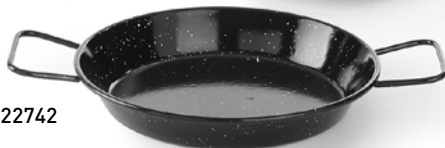

### ENAMELLED PAELLA PANS

- With 2 handles
- Enamelled sheet steel

code	mm
622704	Ø100x(H)20
622711	Ø120x(H)25
622728	Ø150x(H)27
622735	Ø200x(H)36
622742	Ø240x(H)40

622810



622841



622858

### ENAMELLED PAELLA BOWLS

- Deep model
- Enamelled sheet steel

code	mm
622810	Ø145x(H)40
622827	Ø170x(H)40
622834	Ø185x(H)43
622841	Ø205x(H)57
622858	Ø245x(H)70





426326



426357



426463

**WINE COOLER MINIATURES**

code	mm
426326	Ø97x(H)98
426333	Ø115x(H)110
426340	Ø135x(H)130

**BUCKET MINIATURES**

code	mm
426357	Ø70x(H)77
426364	Ø87x(H)93
426371	Ø125x(H)127

**SNACK CAN**

code	mm
426463	45x50
426470	70x100



426388

**STRAINER MINIATURES**

code	mm
426388	Ø100x(H)54
426395	Ø130x(H)64



426487

**SNACK PAN**

code	mm
426487	185x95x(H)45

TABLEWARE



535271

**NEW!**

**COLANDER SQUARE PERFORATED**

- Square model, with base and 2 handles.

code	mm
535271	169x169x(H)55
535288	218x218x(H)70



535295

**NEW!**

**COLANDER PERFORATED**

- With base and 2 handles.

code	mm
535295	Ø160x(H)65





607015

607022

607039

### SMALL SAUCE PAN WITH SPOUT

- Made of 2.5 mm thick 3-ply material, copper/aluminium/ stainless steel.
- Handle attached by rivets.

code	mm
607015	Ø50x(H)30
607022	Ø75x(H)40
607039	Ø85x(H)50



607046

### SMALL FRYING PAN

- Made of 2.5 mm thick 3-ply material, copper/aluminium/ stainless steel.
- Handle attached by rivets.

code	mm
607046	Ø120x(H)30



## GALVANIZED BUCKETS

- Made of galvanized sheet steel, this creates a rustic look.
- Galvanized steel isn't intended for food contact, line the buckets with our greaseproof paper sheets when using it for serving food.

**NEW!**



425947



425961

### DOUBLE BUCKET WITH HANDLE

- Handle is made of wood.

code	mm
425947	200x100x(H)...
425954	120x240x(H)...

### 3 BUCKETS WITH TRAY

code	mm
425961	365x130x(H)125



425978



425992

### CUTLERY & NAPKIN CADDY

- With handle which is fitted with a wooden grip.

code	mm
425978	245x167x(H)132

### PARTY TUB

code	mm
425992	400x330x(H)220



425930



425909

425916

425923

425985

### FLARED TUB

code	mm
425930	100x100x(H)80

### BUCKETS WITH HANDLE

- Fitted with a handle.

code	mm
425909	Ø70x(H)65
425916	Ø100x(H)90
425923	Ø120x(H)115
425985	Ø160x(H)140





### RAMEKIN

- Ribbed

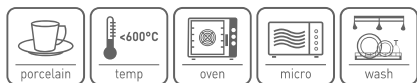

code	mm
783153	Ø70x(H)35
783160	Ø90x(H)48
783627	Ø100x(H)25
783177	Ø120x(H)55



### RAMEKIN

- Ribbed

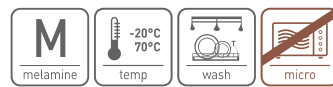

code	packed	mm
565643	4	Ø60x(H)25
561706	50 ml	Ø70x(H)35
565650	4	Ø70x(H)35
561713	80 ml	Ø80x(H)40
565667	4	Ø80x(H)40
561720	100 ml	Ø85x(H)45
565674	4	Ø85x(H)45



### RAMEKIN



code	colour	packed per	ml	mm
565605	black	12	45	60x60x(H)35
565612	ivory	12	45	60x60x(H)35
565629	transparent	12	45	60x60x(H)35
565636	terracotta	12	45	60x60x(H)35



### VELOCITY SLANTED BOWLS

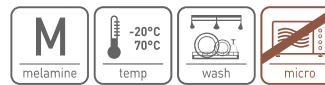

code	mm
564578	70x70x(H)60
564585	97x97x(H)80
564592	110x110x(H)100



### BUTTER & SAUCE DISH

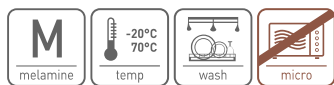

code	colour	packed per	mm
564608	terracotta	3	80x80x(H)30
564561	black	3	80x80x(H)30





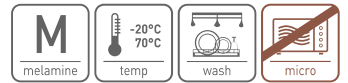

564509

**MINI SAUCEPAN LITTLE CHEF**

– Melamine presentation bowls and trays, shaped like cookware.

code	mm
564509	162x121x(H)30



564516

**MINI GRIDDLE PAN LITTLE CHEF**

– Melamine presentation bowls and trays, shaped like cookware.

code	mm
564516	320x162x(H)20



564523

**MINI ROUND PAN LITTLE CHEF**

– Melamine presentation bowls and trays, shaped like cookware.

code	mm
564523	150x115x(H)37
564530	189x147x(H)37



564554

**MINI OVAL PAN LITTLE CHEF**

– Melamine presentation bowls and trays, shaped like cookware.

code	mm
564547	155x80x(H)37
564554	263x140x(H)37





## SLATE PLATEAUS

- Natural presentation items for serving elegant and exclusive hot or cold dishes.
- Cut out of stone and fitted with anti-slip feet.



### SLATE PLATEAUS ROUND

code	packed per	mm
424629	2	Ø250x(H)5
424636	2	Ø300x(H)5

424612



### SLATE PLATEAUS SQUARE

code	packed per	mm
424643	2	200x200x(H)5
424650	2	250x250x(H)5
424667	2	300x300x(H)5

424643



### SLATE PLATEAUS RECTANGULAR

code	packed per	mm
424681	2	200x100x(H)5
424698	2	300x100x(H)5

424681



## BREAD BAGS

### PAPER BAGS

- Made of food grade washable kraft paper.

code	colour	mm
429211	black	170x170x(H)150
429228	beige	170x170x(H)150

429211



429228



### BREAD BAG ROUND

- Made of durable cotton.
- Available in the color combinations gray/beige and gray/dark gray.

code	colour	mm
429006	Beige	Ø150x(H)150
429013	Dark grey	Ø150x(H)150
429020	Beige	Ø200x(H)200
429037	Dark grey	Ø200x(H)200
429044	Beige	Ø250x(H)160
429051	Dark grey	Ø250x(H)160

429068



429051



429006



429037



## BASKETS

- Polyrattan



### BREAD BASKET - OVAL

code	mm
426500	225x130x(H)55

### BREAD BASKET - RECTANGULAR

code	mm
426807	225x150x(H)65

### BREAD BASKET - ROUND

code	mm
426609	Ø200x(H)65

### BREAD BASKET - OVAL

code	mm
426708	225x110x(H)60

### BREAD BASKET - OVAL

code	mm
426906	375x140x(H)70



### PITTA BREAD BASKET - ROUND

code	mm
425701	Ø150x(H)40
425800	Ø200x(H)50



### PITTA BREAD BASKET - OVAL

code	mm
425503	200x140
425602	230x180



### FRUIT BASKET - Chrome-plated wire

code	mm
426418	Ø 215x(H)205



## SOUP AND SAUCE BOWLS



434208



### SOUP TUREEN

- With lid and serving spoon.

code	liter	mm
434208	2,7	Ø270x(H)120

### SOUP BOWL

- With handles

code	liter	mm
430002	0,35	Ø120x(H)50



430002

### VEGETABLE DISH

- With handles

code	mm
401002	Ø120x(H)30
401101	Ø140x(H)35
401200	Ø160x(H)40



401200

### SAUCE BOAT

- On foot

code	liter	mm
432143	0,085	120x(H)50
432006	0,14	135x(H)70
432105	0,23	160x(H)90
432129	0,28	200x(H)105
432136	0,46	240x(H)120



432136





## VACUUM JUGS

- Double walled stainless steel.
- Seamless structure.
- Vacuum insulation.
- Metal chromed cover, lever, spout and handle.
- High insulation value.



445815

445822

445839



### VACUUM JUG

code	liter	ØxH mm
445815	0,6	120x168
445822	1	136x188
445839	1,5	136x258



446508

446607

446706



### VACUUM JUG

- Double walled stainless steel.
- With black push-button cap.
- Top and lid made of polypropylene.

code	liter	ØxH mm
446508	1	145x205
446607	1,5	145x230
446706	2	145x260



446522

446621

446720



### VACUUM JUG

- Double walled stainless steel.
- With yellow push-button cap.
- Top and lid made of polypropylene.

code	liter	ØxH mm
446522	1	145x205
446621	1,5	145x230
446720	2	145x260







448908



**AIR POT**

- Stainless steel mantle
- With press system to tap drinks

code	liter	ØxH mm
448908	2,2	150x340



445877



**AIR POT**

- Double wall vacuum body and PP head
- Rotatable on base
- Zinc alloy lever designed for extra strength
- Lid opens to 125 degrees for brewing and is also detachable for cleaning
- Secure carrying handle
- Drip tray optional

code	liter
445877	3
445891	drip tray



445891

449608



**VACUUM JUG WITH GLASS INNER BOTTLE**

code	colour	liter	ØxH mm
449608	black	1	140x268





### MULTIPURPOSE JUGS

code	liter	mm
451502	0,35	Ø76x(H)93
451519	0,6	Ø90x(H)112
451526	0,9	Ø102x(H)125
451533	1,5	Ø112x(H)161



### CAPPUCCINO STEAM JUG

- With handle

code	liter	mm
458228	0,3	Ø80x(H)80
458211	0,5	Ø85x(H)110
458204	0,7	Ø95x(H)115
458006	0,9	Ø115x(H)115



### CREAM JUG

- Straight model

code	liter	mm
450109	0,03	Ø35x(H)35
450208	0,04	Ø40x(H)40
450307	0,07	Ø50x(H)55
450406	0,12	Ø60x(H)60
450505	0,25	Ø75x(H)75



### MILK JUG

- Straight model

code	liter	mm
451007	0,35	Ø85x(H)110
451106	0,75	Ø100x(H)120



### COFFEE/ TEA POT WITH LID

- With hinged lid.

- Straight model.

code	liter	mm
453001	0,3	Ø74x(H)95
453100	0,5	Ø74x(H)123
453209	1	Ø97x(H)142
453308	1,5	Ø120x(H)158
453407	2	Ø126x(H)185





456514

### TEA BOX

- Wood with acrylic window
- 12 compartments



code	mm
456514	300x280x(H)90



570807

### TEA STRAINER - WITH HINGED HANDLE

- For herbs and tea
- With hinged handle



code	mm
570807	Ø40x150



638101

### TEA & HERB STRAINER

- For herbs and tea
- With wire handle



code	mm
638101	Ø70x225



592038

### LEMON SLICE SQUEEZER



code	packed per	mm
592038	6	80x70



523629

523636

### SUGAR CUBE TONGS



code	packed per	mm
523629	2	160
523636	2	113



452325

452714

### SUGAR/WHIPPED CREAM DISH



code	packed per	mm
452714	6	Ø65
452325	4	Ø100





452400

### SUGAR DISPENSER

- Glass dispenser.
- Spout made of stainless steel 18/0.



code	ml	mm
452400	200	Ø80x(H)140



452424

### HONEY DISPENSER

- Glass dispenser.
- Stainless steel lever.

code	mm
452424	Ø80x(H)115



465370

### CHEESE/SUGAR DISH

- With glass dish
- Including stainless steel spoon



code	mm
465370	Ø130x(H)90



631300

631102

631201

### SHAKER

code		mm
631201	pepper & salt shaker	Ø55x(H)75
631102	parmesan shaker	Ø55x(H)75
631300	wire mesh powder shaker	Ø55x(H)75



786413

### CONDIMENT SET

- 2-piece set: salt, pepper

code		mm
786413	pepper & salt	Ø42x(H)80



786420

### CONDIMENT SET

- 3 piece set: salt, pepper, toothpick holder

code		mm
786420	pepper, salt & toothpick	125x54x(H)90

### TOOTHPICK HOLDER

- Glass holder
- Stainless steel cap



code	packed per	mm
468821	6	Ø40x(H)70



468821



452103

### SUGAR BOWL

- With hinged lid



code	ml	mm
452103	300	Ø85x(H)80



452202

### SUGAR BOWL

- Without lid



code	ml	mm
452202	300	Ø85x(H)65

460245



### OIL AND VINEGAR SET

- Holder made of chrome-plated iron.
- Two oil/vinegar bottles with stainless steel pourers.



code	ml	mm
460245	2x 237	115x60x(H)325
460252	2x 470	130x70x(H)370







18/0  
stainless steel

465301

**CONDIMENT SET**  
- 2-piece - salt, pepper  
- Matt finish

code	mm
465301	85x55x(H)115



18/0  
stainless steel

465349

**CONDIMENT SET**  
- 2-piece - oil, vinegar  
- Matt finish

code	ml	mm
465349	150	120x75x(H)185



18/0  
stainless steel

465332

**CONDIMENT SET**  
- 3-piece - salt, pepper, mustard  
- With stainless steel mustard spoon  
- Matt finish

code	mm
465332	100x95x(H)115



18/0  
stainless steel

465318

**CONDIMENT SET**  
- 3-piece - salt, pepper, napkin holder  
- Matt finish

code	mm
465318	85x75x(H)115



18/0  
stainless steel

465325

**CONDIMENT SET**  
- 3-piece - salt, pepper, toothpick holder  
- Matt finish

code	mm
465325	90x90x(H)115



18/0  
stainless steel

465356

**CONDIMENT SET**  
- 4-piece - salt, pepper, oil, vinegar  
- Matt finish

code	mm
465356	130x110x(H)185



18/0  
stainless steel

465363

**CONDIMENT SET**  
- 5-piece - salt, pepper, oil, vinegar, toothpick holder  
- Matt finish

code	mm
465363	130x110x(H)185



S.S.  
stainless steel

wash

465387

**SALT AND PEPPER SHAKER SET**  
- Glass shaker.  
- Stainless steel lid with S and P shaped dispensing opening.

code	mm
465387	Ø40x(H)70



S.S.  
stainless steel

wash

461167

461266

**SALT AND PEPPER SHAKER**  
- Glass shaker  
- Stainless steel lid with S or P shaped dispensing opening.

code	packed per	mm
461167	pepper 6	Ø40x(H)70
461266	salt 6	Ø40x(H)70





469422



469477



469415  
469446



469460  
469491



Unique grinding adjustment mechanism at the bottom of the mill, adjustable in 4 steps from fine to coarse



The grinding mechanism is not adjustable



469408  
469439



469453  
469484



### PEPPER MILLS

- Durable ceramic grinding mechanism, the precise placement of the grinding wheel leaves a gap between the teeth which reduces wear.
- Fitted with a unique grinding adjustment mechanism at the bottom of the mill, adjustable in 4 steps from fine to coarse.
- The cap is easy to remove for refilling, its screw tension does not influence the grinding mechanism.
- Available with the appearance of either beech wood (light) or walnut wood (dark).

code		mm
469408	light wood	(H)100
469453	dark wood	(H)100
469415	light wood	(H)215
469460	dark wood	(H)215
469422	light wood	(H)310
469477	dark wood	(H)310

### SALT MILLS

- Durable ceramic grinding mechanism, the precise placement of the grinding wheel leaves a gap between the teeth which reduces wear.
- The grinding mechanism is not adjustable, which gives consistent results.
- The cap is easy to remove for refilling, its screw tension does not influence the grinding mechanism.
- Available with the appearance of either beech wood (light) or walnut wood (dark).

code		mm
469439	light wood	(H)100
469484	dark wood	(H)100
469446	light wood	(H)215
469491	dark wood	(H)215



### PEPPER AND SALT MILLS - TRANSPARENT

- Made of acrylic (PMMA).
- Durable ceramic grinding mechanism, the precise placement of the grinding wheel leaves a gap between the teeth and reduces abrasion.
- Pepper mill fitted with unique grinding adjustment mechanism at the bottom of the mill, adjustable in 4 steps from fine to coarse.
- The grinding mechanism of the salt mill is not adjustable, which gives consistent results.
- The cap is easy to remove for refilling, its screw tension does not influence the grinding mechanism of the pepper mill.



469385



469392

code		mm
469385	pepper mill	(H)105
469392	salt mill	(H)105





400203

**SERVING DISH**

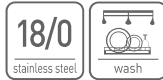

code	mm
400203	205x155



441107

**ICE-CREAM CUP**

- On foot



code	mm
441107	Ø90x(H)50



595008

**RECEPTION BELL**

- Chrome-plated with metal base



code	ØxH mm
595008	85x60



444023

**TABLECLOTH CLIP**



code	packed per	mm
444023	4	50x(H)40



428511

**NAPKIN HOLDER**

- Matt finish



code	mm
428511	170x30x(H)70



428528

**NAPKIN HOLDER**

- Chrome-plated wire



code	mm
428528	190x190x(H)65



441466

**EGG CUP**

- Low model



code	packed per	mm
441466	6	Ø85x(H)15



441367

**EGG CUP**

- On foot



code	packed per	mm
441367	6	Ø50x(H)45



441503

**EGG SPOON**

- White ABS



code	packed per
441503	6





440704



421550



421574



can be used  
as a cutlery  
holder



**TABLETOP LITTERBIN**

- Stainless steel container
- Black ABS tumble cover



**TABLETOP LITTERBIN**



**TABLETOP LITTERBIN OR CUTLERY HOLDER**

code	mm	code	mm	code	colour	mm
440704	Ø120x(H)165	421550	Ø120x(H)180	421574	black	Ø130x(H)160



665251

**MENU CARD TABLE STAND**

- Supplied without menu card.



code	packed per	mm
665251	6	80x77x(H)18



595206

**TAB HOLDER**

- With clamp.



code	packed per	mm
595206	3	152x110



665503

665510

**MENU CARD TABLE STAND**

code	mm
665503	100
665510	200



595305

**TAB GRABBER**

- With clamp.



code	packed per	mm
595305	2	Ø40x(H)104







440216



440223

## NEW!

### WALL MOUNTED ASHTRAY

- Very robust design, easy to mount against walls and poles.
- Easy to empty thanks to the bottom that can be opened and closed with a key.



code	mm
440216	Ø75x(H)460

## NEW!

### STANDING ASHTRAY POLE

- Very robust design, can be mounted on the floor or stand free.
- Easy to empty, upper part can be unlocked with a key and then emptied.
- Base is Ø170 mm, pole is Ø80 mm.



code	mm
440223	Ø170x(H)920



440506

### ASH COLLECTOR

- With hinged lid
- For fire safe emptying ashtrays



code	mm
440506	202x170x(H)91





440605

**ASHTRAY WITH LOWER TRAY**



code	mm
440605	Ø140x(H)40



569757

**ASHTRAY**

- Made of black melamine.



code	mm
569757	Ø146



440407

**ASHTRAY WITH LID**



code	packed per	mm
440407		Ø90x(H)28
440490	3	Ø90x(H)28



440803

**ASHTRAY PROFI LINE**



code	mm
440803	Ø75x(H)28
440858	Ø95x(H)28
440902	Ø120x(H)28



440001

**ASHTRAY WITH FIRE RIM**



code	mm
440001	Ø140x(H)30
440100	Ø160x(H)30



440872

**ASHTRAY KITCHEN LINE**



code	mm
440872	Ø80x(H)30
440865	Ø100x(H)30



440209

**ASHTRAY WITH PUSH BUTTON**



code	mm
440209	Ø90x(H)45



## DOOR SIGNS

- With self-adhesive strip



code	type	mm
663608	men	Ø75
663615	women	Ø75
663622	toilets	Ø75
663639	no smoking	Ø75
663646	wheelchair	Ø75
663653	mobile off	Ø75



663608



663615



663622



663639



663646



663653

## WALL SIGNS ROUND

- With self-adhesive strip.



code	type	mm
663783	smoking	Ø75
663790	no smoking	Ø75
663820	smoking - big	Ø160
663806	no smoking - big	Ø160



663820



663806

## TABLE SIGN 'NO SMOKING'

- 2 sides printed



code	mm
663660	50x(H)40



663660

## TABLE SIGN RESERVED

- Black - white.

- Printed on 2 sides.



code		packed per	mm
663462	"reserved"	1	130x35x(H)40
663745	"gereserveerd"	1	130x35x(H)40
663479	"reserviert"	1	130x35x(H)40
663486	"réservé"	1	130x35x(H)40

663745



663462

## TABLE SIGN RESERVED



code		packed per	mm
663691	"Gereserveerd" & "Réserve"	4	50x(H)40
663707	"Reserviert"	4	50x(H)40

663691



## TABLESTAND NUMBERS

- Sets of multiple numbers

- 12 numbers per set



code		mm
663844	Numbers 1-12	50x(H)40
663851	Numbers 13-24	50x(H)40
663868	Numbers 25-36	50x(H)40
663875	Numbers 37-48	50x(H)40
663882	Numbers 49-60	50x(H)40
663899	Numbers 61-72	50x(H)40

663844





664025



664032



664049



664018

664001

### WALL BLACKBOARD

- Black, with wooden frame

code	mm
664025	300x400
664032	400x600
664049	600x800

### PAVEMENT BLACKBOARD

- Black, with wooden frame

code	mm
664001	500x850
664018	700x1200



664100



664117

### PAVEMENT BLACKBOARD

- Black, with steel frame.

code	mm
664100	700x1100

### PAVEMENT BLACKBOARD

- Black, with steel frame.

code	mm
664117	500x850







**TABLETOP BLACKBOARD**

code	packed per	mm
664087	2	148x97
664094	2	210x150



**TABLETOP BLACKBOARD**

- Black, with wooden stand

code	packed per	mm
664056	2	150x230
664063	2	210x320



**BLACKBOARD WITH EASEL**

- Black, with wooden easel

664070

code	mm
664070	220x360



**BLACKBOARD MARKERS**

- 8 Markers with round nib, writing width 3 mm

code	
664278	1 white, 1 red, 1 blue, 1 green, 1 yellow, 1 purple, 1 orange and 1 pink marker



664261

664209

664216

**BLACKBOARD MARKERS**

- With oblique nib, writing width 2 to 6 mm

code	
664216	1 pink, 1 green, 1 blue and 2 white markers
664209	5 white markers
664261	1 white, 1 orange, 1 yellow, 1 red and 1 purple marker



664223

664230

664247

664254

**BLACKBOARD MARKERS**

- With wide flat nib, writing width 15 mm

code	
664223	3 white markers
664230	1 pink, 1 green and 1 blue marker
664247	1 white, 1 red and 1 yellow marker
664254	1 white, 1 purple and 1 orange marker





Soup name card holder in lid

Lid with insulated handle and ladle recess



860502

Digital touch panel with display that alternates between set and actual soup temperature

Thermostat adjustable from 65° to 95°C by 1° increments



Overheating protection – with alarm for low water level

**SOUP KETTLE**

- Thermal insulation reduces energy consumption and keeps the outside cool.
- These unique advantages can reduce energy consumption by up to 30%.
- Removable lid made of tough, transparent polycarbonate.
- Aluminium water pan for efficient heat transfer.
- Food pan made of stainless steel 18/8.
- Polypropylene housing.
- Ring allows safer and easy removal of food pan to refill water pan.
- Ideal for buffets.

code	liter	V	W	mm
860502	8	230	450	Ø370x(H)300



S.S.  
stainless steel



### SOUP KETTLE

- Bain-marie Hendi
- 8 litres
- Black coated
- With stainless steel inner pan and hinged lid
- Fitted with power regulator
- Ideal for buffets
- Including magnetic signs

code	liter	V	W	mm
860083	8	230	435	Ø340x(H)360



860083



### SOUP KETTLE

- Bain-marie Hendi.
- 8 liter.
- With stainless steel inner pan and hinged lid.
- Fitted with power regulator.
- Ideal for buffets.
- Including magnetic signs.

code	liter	V	W	mm
860304	8	230	435	Ø340x(H)360

S.S.  
stainless steel



860304







204825

### CHAFING DISH ELECTRIC TELLANO

- Gastronorm 1/1.
- Water pan made of heat-resistant polypropylene.
- Continuous settings up to 85°C.
- On/off switch, pilot light.
- Very silent whilest heating.
- Including GN 1/1 food pan 65 mm deep.



code	liter	V	W	mm
204825	9	230	900	573x348x(H)284



204900

### CHAFING DISH ELECTRIC POLLINA

- Gastronorm 1/1.
- Temperature adjustable up to 85°C.
- With lid stand.
- On/off switch with integrated indication light.
- Including Gastronorm 1/1 food pan 65 mm deep.
- Suitable for pans up to 100 mm deep.



code	liter	V	W	mm
204900	9	230	800	615x355x(H)280



204832

### CHAFING DISH ELECTRIC TESINO

- Water pan made of heat-resistant polypropylene.
- Continuous settings up to 85°C.
- Very silent whilest heating.
- On/off switch, pilot light.
- Including 6,8 ltr food pan.



code	liter	V	W	mm
204832	6,8	230	500	Ø405x(H)248



239902

### CHAFING DISH ELECTRIC SAVOI

- With glass lid.
- Including food pan Ø 400 mm, 65 mm deep.
- Continuous settings up to 85°C.
- On/off switch, pilot light.



code	liter	V	W	mm
239902	6,8	230	1000	Ø400x(H)250







**NEW!**

**CHAFING DISH GN 2/3 INDUCTION**

- High gloss stainless steel chafing dish suitable for induction heaters up to Ø260 mm.
- Induction bottom is encapsulated, also suitable for electric hobs and chafing dish fuel.
- The lid is removable for easy cleaning and is fitted with a sturdy handle, glass window with steam release and damper for soft closing.
- Comes with an integrated spoonholder and a 60mm deep GN2/3 foodpan (6L).
- Two versions, with or without frame.



470084

code	
470084	chafing dish
470091	set chafing dish + stand



**INDUCTION HEATER 800W**

- Black crystal glass top surface and plastic housing.
- Power regulation adjustable in 10 steps, fitted with electronic overheating protection.
- Control panel with LED display and touch control, can be mounted in a countersunk manner.
- Can be used as a heater chafing dishes equipped with special adapter.
- Also suitable for built-in installation with the optional separately available ring [239186].



239193

code	V	W	mm
239193	230	800	Ø245x(H)68
239186			Mounting ring stainless steel



239186



809709

With safety switch



**CHAFING DISH HEATER FOR UNDERNEATH WATER PAN**

- For chafing dish GN 1/1.
- With safety switch.

code		V	W	mm
809709	Element only	230	400	200x320



809600

**CHAFING DISH HEATER**

- For use as an alternative to conventional fuel holder
- Only suitable for chafing dishes with a flat bottom
- Extremely suitable for chafing dishes without preparation for electrical elements
- Specifically suitable for Hendi chafing dishes with item number 470008, 475201, 470206 and 471005

code	V	W	mm
809600	230	500	Ø130x(H)100



18/0  
stainless steel



475904



**CHAFING DISH GASTRONORM 1/1**

- Model Economic.
- High-gloss polished lid and lid stand.
- Including chafing dish fuel holders and stainless steel food pan 65 mm deep.
- Suitable for food pans up to 65 mm deep.

code	liter	mm
475904	9	600x358x(H)295
472613	2 pcs.	9
		600x358x(H)295



475201

18/0  
stainless steel

**CHAFING DISH GASTRONORM 1/2**

- Model Economic
- High-gloss polished lid and lid stand
- Including chafing dish fuel holder and stainless steel food pan 65 mm deep
- Suitable for food pans up to 65 mm deep.

code	liter	mm
475201	4,5	385x295x(H)310



470619

S.S. 18/0  
stainless steel stainless steel

**CHAFING DISH - ROUND**

- Glass lid
- Including chafing dish fuel holder and stainless steel food pan

code	liter	mm
470619	3,5	Ø390x(H)270



472507

S.S. 18/0  
stainless steel stainless steel

**SOUP CHAFING DISH**

- Model Economic
- Including chafing dish fuel holder and stainless steel soup pan with lid

code	liter	mm
472507	8	Ø370x(H)325





471005



**CHAFING DISH GASTRONORM 1/1**

- Model Fiora.
- Stackable frame with high-gloss polished lid and lid stand.
- Including two chafing dish fuel holders and stainless steel food pan 65 mm deep.
- Suitable for Gastronorm pans of up to 100 mm deep.



code	liter	mm
471005	9	585x385x(H)315

**CHAFING DISH SET**

- Consists of:
- Chafing Dish "Fiora" as in 471005
- 2 additional GN 1/2 pans 65 mm deep
- 3 additional GN 1/3 pans 65 mm deep

code	mm
471050	585x385x(H)315



3 x

471050

2 x





## CHAFING DISHES PROFI LINE SATIN FINISH

- Ideal for buffets and catering. By using high-quality material and a beautiful finish, these chafing dishes give every presented dish a certain allure.
- The chafing dishes and accessories are entirely made from durable stainless steel.

**NEW!**







470251



470275

### CHAFING DISH GN 1/1 SATIN FINISH

- The lid is fitted with a friction brake, it stays in the position in which it is left. The lid can be removed to ease cleaning.
- Supplied with removable water pan, GN 1/1 65 mm deep food pan and 2 chafing dish fuel can holders.

code	liter	mm
470251	9	570x405x(H)290

### CHAFING DISH GN 2/3 SATIN FINISH

- The lid is fitted with a friction brake, it stays in the position in which it is left. The lid can be removed to ease cleaning.
- Supplied with removable water pan, GN 2/3 65 mm deep food pan and chafing dish fuel can holder.

code	liter	mm
470275	6	395x430x(H)290



470268



470282

### CHAFING DISH GN 1/2 SATIN FINISH

- The lid is fitted with a friction brake, it stays in the position in which it is left. The lid can be removed to ease cleaning.
- Supplied with removable water pan, GN 1/2 65mm deep food pan and chafing dish fuel can holder.

code	liter	mm
470268	4	365x370x(H)280

### CHAFING DISH ROUND SATIN FINISH

- The lid is fitted with a friction brake, it stays in the position in which it is left. The lid can be removed to ease cleaning.
- Supplied with removable round water pan, round 65mm deep food pan and chafing dish fuel can holder.

code	liter	mm
470282	6	465x420x(H)320



## CHAFING DISHES PROFI LINE MIRROR FINISH

- Ideal for buffets and catering. By using high-quality material and a beautiful finish, these chafing dishes give every presented dish a certain allure.
- The chafing dishes and accessories are entirely made from durable stainless steel.

**NEW!**







470213



470237

### CHAFING DISH GN 1/1 MIRROR FINISH

- The lid is fitted with a friction brake, it stays in the position in which it is left. The lid can be removed to ease cleaning.
- Supplied with removable water pan, GN 1/1 65mm deep food pan and 2 chafing dish fuel can holders.

code	liter	mm
470213	9	570x405x(H)320

### CHAFING DISH GN 2/3 MIRROR FINISH

- The lid is fitted with a friction brake, it stays in the position in which it is left. The lid can be removed to ease cleaning.
- Supplied with removable water pan, GN 2/3 65mm deep food pan and chafing dish fuel can holder.

code	liter	mm
470237	6	395x405x320



470220



470244

### CHAFING DISH GN 1/2 MIRROR FINISH

- The lid is fitted with a friction brake, it stays in the position in which it is left. The lid can be removed to ease cleaning.
- Supplied with removable water pan, GN 1/2 65mm deep food pan and chafing dish fuel can holder.

code	liter	mm
470220	4	365x345x(H)345

### SOUP CHAFING DISH MIRROR FINISH

- The round soup container is placed in a large water pan which provides plenty of heat to easily keep the soup hot.
- Soup container fitted with two handles.
- The lid has a recess for the spoon.
- Supplied with removable water pan, round soup container and chafing dish fuel can holder.

code	liter	mm
470244	10	Ø420x(H)380



**NEW!**



470190



**FOOD PAN GN1/1 WITH 2 COMPARTMENTS**

- This GN food pan has two compartments of 3,75 liter each.

code	liter	mm
470190	7,5	530x325x(H)65



470909

470909



**CONVERSION FOR 2 BAIN-MARIE PANS**

- Fits all GN 1/1 types chafing dishes

code	liter	mm
470930	conversion	530x325
470909	bain marie pan	4,2 Ø220x(H)190

470930



**DISH WARMER 2 BURNERS**

- With stainless steel frame and grips
- Anodized aluminium hotplate
- Scratch-proof
- Including 2 candle light holders



code	mm
463000	330x180x(H)65

463000



**DISH WARMER 3 BURNERS**

- With stainless steel frame and grips
- Anodized aluminium hotplate
- Scratch-proof
- Including 3 candle light holders



code	mm
463109	450x180x(H)65

463109



464809



**CANDLE HOLDER**

code	mm
464809	Ø 46







**ROLLTOP-CHAFING DISH  
GASTRONORM 1/1**

- Elegant buffet chafing dish.
- Patented extra quiet opening mechanism.
- Roll-top cover retractable up to 180°.
- Optional installation of electrical heating element.
- Highly polished stainless steel.
- Steel frame 2.3 mm, cover 1.2 mm.
- Set includes two fuel can holders and a GN 1/1 – 65 mm food pan.

code	liter	mm
470305	9	660x490x(H)460



470305



**ROLLTOP-CHAFING DISH - ROUND**

- Elegant buffet chafing dish.
- Patented extra quiet opening mechanism.
- Roll-top cover retractable 180°.
- Set includes one fuel can holder and food pan (Ø390x(H)60 mm).
- Highly polished stainless steel.
- Steel frame 2.3 mm, cover 1.2 mm thick.

code	liter	mm
470312	5,6	510x540x(H)480



470312



**ROLLTOP-CHAFING DISH  
GASTRONORM 1/1**

- Model Rental-Top.
- Solid base with high-gloss polished roll top lid made of 18/0 stainless steel.
- Includes two chafing dish fuel holders and stainless steel food pan 65 mm deep.
- Bottom fitted with fastening bolts for electric heating element prod. no. 809709.
- Suitable for Gastronorm pans up to 100 mm deep.

code	liter	mm
470206	9	590x340x(H)400



470206



## CHAFING DISH FUEL

- Burning gel is made of natural (bio) ethanol alcohol, mixed with water and a thickening agent to make it a solid or gel. Hendi burning gel is artificially made to taste so bitter that it is impossible to swallow. To safely and efficiently heat e.g. chafing dishes, we urgently advise burning gel to be used in special fuel holders.
- Hendi offers most common variants of burning gel. The heating capacity is equal through the range while the heating rate is dependent upon the size of the flame, determined by how far open the lid of the fuel holder is kept.
- "Blaze" brand has a shorter, more intense burn - it is recommended for applications where the burning time will be around 2 hours. "Hendi" brand burning gel is recommended when over 3 hours of heating will be required.
- All Hendi and Blaze burning gel burns soot and odour free.
- Cartouches and cans without special fuel holders become very hot during use, thus creating a significant risk of burns if they are not placed inside a fuel holder. Danger of burns!
- These fuel holders are both included with Hendi chafing dishes and separately available.
- Always read the instructions on the product before use.
- Make sure there are no open flames or hot objects nearby when working with burning gel. The flammable vapour easily escapes the container.
- Make sure no (condensation) water drips into the burning fuel.

- It can cause dangerous sputtering and splashing of fuel.
- Only light the fuel after the cans inside the fuel holders have been placed in the final location.
- The flames are almost entirely blue, making them very hard to see in light. Caution is advised.
- Only ever extinguish the fuel by closing the lid of the fuel holder.
- Refilling: Always make sure the can and its holder have completely cooled down. Remove the can from the holder to refill the can.
- Storage: Always store in closed containers in a dark, well ventilated location, below 20°C. For storing larger amounts of fuel please consult your local regulations.
- If the instructions above are followed, the risk of accidents will be minimal.
- In case of a starting/small fire: use a fire blanket (or a large, wet blanket) to cover the fire and deprive it of oxygen.
- In case of fire on clothes/body: use a fire blanket or a powder/CO<sub>2</sub> fire extinguisher. Never try to extinguish the fire with a small towel as this would only spread the fuel and the flames!
- After extinguishing the fire keep the body cool for 15 minutes or until medical assistance arrives. Leave clothes in place. Always seek medical assistance immediately.



193310



194355

### CHAFING DISH FUEL BLAZE

- Blue Blaze B-B100 can
- 200 grams can
- Burning time ± 2.5 hours per can
- Pallet: 56 x 193310

code		order unit
193310	box 72 pieces	1
193327	set of 12 pieces	6

### CHAFING DISH FUEL CAN

- 200 grams pack for chafing dish.
- Burning time: ± 3 hours.
- Pallet: 50x 194355, 140x 194300.

code		order unit
194355	box of 72	1
194300	box of 24	1



470527

### CHAFING DISH FUEL CAN HOLDER



code	packed per	mm
470527	2	Ø90x(H)60





190401



195505

195109

**CHAFING DISH FUEL BUCKET**

- Bucket 4 kilos

code	order unit
190401	4

**CHAFING DISH FUEL JERRY CAN**

- Jerry can 5 liter.

code	order unit
195505	4

**CHAFING DISH FUEL BOTTLE**

- Bottle 1 liter

code	order unit
195109	12

**FUEL DISPENSER**

- Suitable for e.g. can of chafing dish fuel prod. no. 195505

code	length 280 mm
195604	



195604



190036

**FUEL FOR FONDUE-BURNERS**

- For gourmet, fondue, rechauds and stone grills.
- 80 grams portion packs.
- Burning time: ± 2 hours.
- For use with 111420.

code	packed per
190036	3



111420

**FONDUE-BURNER**

- Suitable for fuel for fondue-burners.

code	packed per	mm
111420	2	Ø90



## LIQUID FUEL WITH WICK

- Burns without soot or odours.
- This fuel is made of pure diethylene glycol (DEG), which is also used as antifreeze in radiators. By using a wick the DEG can be vaporized and burned despite its relatively high flame point of 143°C.
- HENDI sells this fuel in closed, non-refillable metal cans of 145 or 200 grams. In addition, 198 gram cans of "Blaze" brand aluminium cans are available.
- The burning time of a can is inversely proportional to the intensity of its flame, which may be adjusted by changing the exposed height of the wick.
- Use: place the can directly below a chafing dish or other heating appliance suitable for use with liquid fuel open flames.
- Burning time: ± 4 hours for 145 gram cans, ± 6 hours for 198 and 200 grams cans.
- Heat output: about 50% of ethanol-based burning gel.
- Advantages in comparison to burning gel:
  - Safer to use. No hazardous refilling. Flame is more visible and predictable.
  - Cans stay cool enough to touch safely. May be used without fuel holder.
  - Safer in case of accidents. Any spillage will be minimal and difficult to ignite.
  - Properly re-sealable and re-usable.
  - Easy to extinguish by blowing or replacing the cap.
  - Cost per burning hour comparable to ethanol-based burning gel.
  - Less intense flame. Reduces chance that Chafing Dish water pans will boil dry.
- CAUTION:
  - Diethylene Glycol is a hazardous irritant. Always wash hands after skin contact with the liquid, preferably wear latex gloves to adjust the wick height.
  - A Material Safety Data Sheet (MSDS) is available on the HENDI website, we recommend printing a copy and keeping it nearby.



193617

### LIQUID FUEL BLAZE

- Burns soot and odour free

code	order unit	packed per	g
193617	1	24 in box	198
193624	4	set 6 pieces	198

Adjustable wick length



The can doesn't get hot and doesn't leak when tilted



Use the same can several times





## LIQUID FUEL WITH WICK

- HENDI tin with wick, contains 100% diethylene glycol.
- Burns up completely.
- Soot and odour free.
- Special wick provides proper burning temperature and time.
- The can does not overheat, no fuel holder needed.
- Equal flame temperature and height during the whole burning process.
- Box 4x6 tins.
- Due to the special cap, it is possible to use the same can several times, store it and transport it safely.



193938

Burns ± 4 hours



193761

Burns ± 6 hours

code		order unit	packed per
193938	burns ± 6 hours	1	24 in box
193716	burns ± 6 hours	4	6 in tray
193952	burns ± 4 hours	1	24 in box
193761	burns ± 4 hours	4	6 in tray

Adjustable  
wick length



The can doesn't get hot  
and doesn't leak when tilted



Use the same  
can several times



## BUFFET LADLES AND SERVING SPOONS



# NEW!



529089

529096

529058

529065

529072



720103

720608

720400

721308

720509



721209

721100

720905

721001

720806

721407

### SERVING SPOON

code	mm
529058	60x305
529065	71x321

### SLOTTED SPOON

code	mm
529072	71x321

### SOUP LADLE

code	liter	mm
529089	0,05	69x270
529096	0,09	85x308

### CARVING FORK

code	mm
720103	325

### SALAD FORK

code	mm
720608	305

### SAUCE SPOON

code	liter	mm
720400	0,03	290

### SOUP LADLE

code	liter	mm
720509	0,12	Ø90x315
721308	0,06	Ø70x285

### SPAGHETTI SPOON

code	mm
721209	325

### CAKE KNIFE / SERVER

code	mm
721100	290

### SKIMMER

code	mm
720905	Ø110x365

### SLOTTED SPATULA

code	mm
721001	325

### SERVING SPOON

code	mm
720806	325
721407	300



## CHAFING DISH LADLES AND SERVING SPOONS

- With polypropylene handle



### SOUP LADLE

code	liter	mm
529003	0,09	Ø90x335
529010	0,11	Ø80x300

### SERVING SPOON

code	mm
529300	350

### SKIMMER

code	mm
529201	345

### SKIMMER, ROUND

code	mm
529041	370



### CAKE SCOOP

code	mm
529027	310

### CARVING FORK

code	mm
529102	345

### SLOTTED SPATULA

code	mm
529409	355

### SPAGHETTI SPOON

code	mm
529034	370



### SPOON HOLDER

code	mm
722107	110x264



722107



## LADLES AND SERVING SPOONS, HEAT RESISTANT



### SALAD CUTLERY

code		colour	mm
563908	Salad spoon	white	305
564004	Salad fork	white	305

### SAUCE SPOON

code	colour	liter	mm
563502	white	0,07	235
563557	black	0,07	235
563700	white	0,14	300
563755	black	0,14	300

### SALAD SPOONS



### SALAD SPOON

code	colour	liter	mm
564103	white	0,03	235
564158	black	0,03	235
564202	transparent	0,03	235

### SALAD SPOON

code	colour	liter	mm
564400	white	0,06	335
564455	black	0,06	335

### SAUCE LADLE

code	colour	liter	mm
563632	Ivory white	0,04	180
563649	Black	0,04	180





## SERVING TONGS

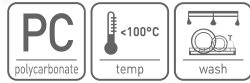

### SERVING TONGS

code	colour	length (mm)
657607	black	230
657621	transparent	230



### CAKE TONGS

- Decorative tongs

code	length (mm)
171615	220



### PASTRY TONG

code	length (mm)
523018	215



### SALAD TONGS

code	length (mm)
523315	212



### SPAGHETTI TONGS

code	length (mm)
523216	200





424186

**ROLLTOP DISPLAY COOLED - GASTRONORM 1/1**

- Cooling by included ice pack, to go below 0°C.
- Stainless steel Gastronorm 1/1 serving tray included.
- With transparent polycarbonate rolltop cover.
- ABS housing.

code	set	mm
424186	set	555x357x(H)175
424193	Cooling element for use with cooling tray 424186	430x275



424193



**THERMO-TRAY RECTANGULAR**

- 5-piece set
- ABS with transparent PS plastic cover
- Including stainless steel tray
- 2 cooling elements

code	mm
424155	430x290x(H)150



424155





871805



**ROLL TOP DISPLAY COOLED**

- ABS plastic with transparent SAN plastic rolltop cover
- Including stainless steel tray and 2 cooling elements

code	mm
871805	440x320x(H)205



871812



**ROLL TOP DISPLAY COOLED**

- Double tray
- ABS plastic with transparent SAN rolltop cover
- Including 2 stainless steel trays and 4 cooling elements

code	mm
871812	440x320x(H)440



871706

**ROLL TOP DISPLAY**

- ABS plastic with transparent SAN plastic rolltop cover



code	mm
871706	465x310x(H)190



871713

**ROLL TOP DISPLAY**

- Double tray, ABS plastic with transparent SAN plastic rolltop cover



code	mm
871713	465x310x(H)410







427507

**ROLLTOP PRESENTATION COVER**

- Clear polycarbonate.



code		mm
427507	GN 1/1	540x330x(H)180



866009

**PRESENTATION COVER**



code		mm
866009	GN 1/1	545x335x(H)95



427538

**ROLLTOP PRESENTATION COVER GN 2/3**

- Clear polycarbonate.



code		mm
427538	GN 2/3	365x335x(H)175



427415

**PRESENTATION COVER**



code		mm
427415	GN 1/1	530x325x(H)76







424001

### ROLL TOP SET

- Including stainless steel tray.
- Roll top cover with chrome button.



code		mm
424001	Plateau & roll-top hood	Ø380x(H)240
427514	Top cover only	Ø380x(H)240



980101

### CAKE PLATE WITH COVER

- With polystyrene cover.
- Stainless steel tray.



code	mm
980101	Ø300x(H)110



### CAKE PLATE ROTATABLE

- Stainless steel base.
- Polystyrene cover sold separately.



code		mm
523827	cake plate	Ø300x(H)90
523834	cover	Ø300x(H)110



523834

523827

### CAKE SERVER

- With polypropylene handle



code	mm
523902	260x60



523902

### CAKE SCOOP/CUTTER

- With black polypropylene handle
- With cutting sides



code	mm
523957	280x75



523957



SERVING STANDS



**TIERED STAND**  
- With 3 trays



code	mm
429914	Ø 268-220-166x(H)320



429914



425473



**SERVING STAND FOR PLATES**  
- For 3 plates



code	plates max. Ø	mm
425466	170 mm	185x120x(H)260
425473	275 mm	290x200x(H)440

425466

BUFFET PRODUCTS





480502



480519

**SEA FOOD TRAY STAND**  
- With two serving trays.



code		mm
480519		Ø300-400x(H)200
480502	Stand only	Ø250-200x(H)190

**SALAD BOWL**  
- Transparent blue



code	liter	mm
566909	4	Ø325x(H)100



566909





DISPENSERS AND JUGS



**NEW!**

425299



425411

**JUICE DISPENSER**

- With ice cylinder cooling.
- Easy to clean dripping tray.
- Clear polycarbonate juice container.
- With non-drip tap.

code	liter	mm
425299	8	260x360x(H)560
425411	2x8	580x350x(H)560



**NEW!**

425428



425435



**JUICE DISPENSER**

- With ice cylinder cooling.
- Easy to clean dripping tray.
- Clear polycarbonate juice container.
- With non-drip tap.

code	liter	mm
425428	3	215x315x(H)490
425435	2x3	415x315x(H)490







### JUICE DISPENSER

- With ice cube cooling.
- Clear polycarbonate juice container.
- With non-drip tap.

code	liter	mm
425190	5	280x220x(H)510



425190



### MILK DISPENSER - 10,5 L

- Stainless steel housing.
- With ice cylinder cooling.
- Removable container with non-drip tap.
- Stable bottom plate with dripping tray.

code	liter	mm
425343	10,5	260x360x(H)536



425343



### MULTI DISPENSER

- Suitable for dry foods only.
- Stainless steel stand.
- Polycarbonate dispenser.
- Airtight lid to retain long freshness of the ingredients.
- Hygienic, controlled dosing prevents spillage.
- Mountable to working table or wall.

code	liter	mm
557402	4	184x240x(H)600



557402





425138

### JUICE JUG

- Straight model of scratch resistant plastic with lid.



code	liter	mm
425138	2	Ø120x(H)250



567906

### PITCHER

- Very break resistant.



code	liter	mm
567906	1,8	Ø125x(H)210



425107



425121



425763



### PITCHER WITH ICE TUBE

- Pear shaped model of scratch resistant clear SAN plastic with lid.

- With ice cube tube for cooling.

code	liter	mm
425107	2,2	Ø150x(H)260
425121	3	Ø170x(H)285



### CARAFE

- Cover with pourer

code	liter	mm
425763	1	Ø92x(H)245





274101

**S.S.**  
stainless steel

**CHOCOLATE FOUNTAIN**

- Made of stainless steel.
- With warming function.
- Suitable for 700g chocolate.
- With separate switch for motor and heating element.

code	V	W	mm
274101	230	275	Ø210x(H)390





**CUTTING BOARD WOOD**



505007

**BREAD BOARD**

- Solid beech wood

code	mm
505007	340x200x(H)14



505205

**CARVING BOARD**

- Solid beech wood

- Grooved

code	mm
505205	390x230x(H)16



505106

**CUTTING BOARD WITH GRIP**

- Solid beech wood

code	mm
505106	390x160x(H)13

side with groove



505403

**BAGUETTE BOARD**

- Solid beech wood

- Combined model, 1 side grooved and 1 side ribbed

code	mm
505403	530x325x(H)18



505502

**BAGUETTE BOARD**

- Wooden with removable grid

code	mm
505502	475x322



removable grid  
- easy to clean





**BASKETS**



561102

**BREAD BASKET GN 1/1**

- Rectangular

code	mm
561102	530x320x(H)90



561201

**BREAD BASKET DISPLAY GN 1/2**

- Rectangular.

- Set of 2 with chrome-plated rack.

code	mm
561201	360x280x(H)90/315



561003

**BREAD BASKET**

- Oval

code	mm
561003	380x270x(H)90



426968

**BASKET WITH ROLL TOP COVER**

- Gastronorm 2/3.

- Basket made of heavy duty polypropylene (poly-rattan).

- Roll top hood made of polycarbonate.



code	mm
426968	365x335x(H)245



426951

**BREAD BASKET WITH ROLL TOP COVER**

- Round

- Break resistant

- With stainless-steel wire frame

- Including polycarbonate rolltop cover



code	mm
426951	Ø400x(H)300



561102



561003



426951



426968



561201



## CANDLEHOLDER 5 ARMS

- Self-assembly
- Candles not included



code	height (mm)
466070	380
466087	540
466117	790
466124	1060
466131	1180



466131

466124

466117

466087

466070



428245



### MULTI RACK

- 3 Layers for holding cups and bags of condiments.
- Polished stainless steel stand with three 1 liter bowls.

code	mm
428245	190x240x(H)410



# NEW!



810422



810392



810446



810484



810385



810439



810491

### RETRACTABLE BELT BARRIER

- Barrier system with integrated retractable belt.
- Easy to set up, belt is connected to the post with a clip system.

code		mm
810422	mirror finish	Ø360x(H)825

### BARRIER POST MIRROR FINISH

- Made of stainless steel, very stable and sturdy.
- For use in combination with barrier ropes.

code		mm
810392	post + base	
810446	post	Ø51x935
810484	base	Ø360

### BARRIER POST GOLD FINISH

- Made of stainless steel, very stable and sturdy.
- For use in combination with barrier ropes.

code		mm
810385	pole + base	
810439	pole	Ø51x935
810491	base	Ø360



810453



810460



810477



### BARRIER ROPES

- Made of durable rope with stainless steel hooks at each end.
- For use in combination with barrier posts.

code		mm
810453	red with polished hook	1500
810460	blue with polished hook	1500
810477	red with gold coloured hook	1500





## FOLDABLE CATERING FURNITURE

- Easy to store and transport foldable furniture for outdoor and indoor use.
- Ideal for fairs, events, catering, rental, etc.
- Table top made of HDPE polyethylene, frame made of powder coated metal.
- Easy to clean and dirt-resistant.



810910



### BUFFET TABLE

- Foldable to suitcase model for easy transporting and storage.

code	mm
810910	1830x750x(H)740
810927	1520x700x(H)740

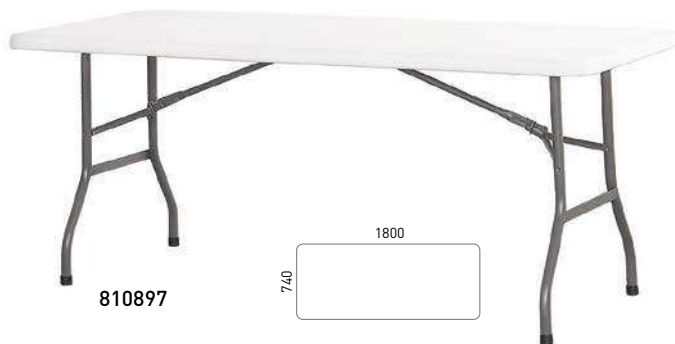

810897



810934

### BUFFET TABLE

code	mm
810897	1800x740x(H)740

### BUFFET TABLE

code	mm
810934	1220x610x(H)740

## NEW!

### TABLE COVER SYMPOSIUM RECTANGULAR

- Fabric: Plain Jersey 160 g/m<sup>2</sup>.
- 90% micro polyester / 10% elasthan.
- No ironing needed.
- Fits rectangular buffet tables.



code	colour	suitable for	mm
814352	cream	810934	1200x760x(H)730
814369	white	810934	1200x760x(H)730
814376	black	810934	1200x760x(H)730
814390	white	810927	1500x760x(H)730
814383	cream	810927	1500x760x(H)730
814406	black	810927	1500x760x(H)730
814420	white	810910 810897	1830x760x(H)730
814413	cream	810910 810897	1830x760x(H)730
814437	black	810910 810897	1830x760x(H)730



814420



814413

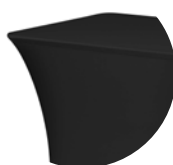

814437







**NEW!**

**BAR TABLE ROUND**

- Thanks to the design of the legs the bar table covers fit perfectly.

code	mm
810521	Ø675x(H)1100
810538	Ø860x(H)1100

**BAR TABLE ROUND**

code	mm
810958	Ø800x(H)1100

**NEW!**



**BAR TABLE COVER**

- Fabric: Plain Jersey 160 g/m<sup>2</sup>.
- 90% micro polyester / 10% elastan.
- No ironing needed.
- Fits bar tables with a table top of Ø80-85cm.



code	colour	suitable for	mm
813157	white	810521 810538	Ø800-850x(H)1050-1150
813171	cream	810521 810538	Ø800-850x(H)1050-1150
813164	black	810521 810538	Ø800-850x(H)1050-1150

**NEW!**

**BAR TABLE COVER**

- Fabric: Plain Jersey 160 g/m<sup>2</sup>.
- 90% micro polyester / 10% elastan.
- No ironing needed.
- Fits bar tables with a table top of Ø70-85cm.



code	colour	mm
813829	white	Ø700-850x(H)1050-1150
813850	cream	Ø700-850x(H)1050-1150
813836	black	Ø700-850x(H)1050-1150



**NEW!**



810941

**BUFFET TABLE ROUND**

code	mm
810941	Ø1800x(H)740



814451



814444



814468

**TABLE COVER SYMPOSIUM ROUND**

- Fabric: Plain Jersey 160 g/m<sup>2</sup>.
- 90% micro polyester / 10% elasthan.
- No ironing needed.
- Fits round buffet tables.

**OEKO-TEX®**  
CONFIDENCE IN TEXTILES

code	colour	suitable for	mm
814444	cream	810941	Ø1800x(H)760
814451	white	810941	Ø1800x(H)760
814468	black	810941	Ø1800x(H)760



810965

**CATERING CHAIR**

code	mm
810965	540x440x(H)840



810989

**CATERING CHAIR - BLACK**

code	mm
810989	540x440x(H)840

**NEW!**



813096

**FOLDING CHAIR COVER**

- Fabric: President 170 g/m<sup>2</sup>.
- 100% polyester.
- No ironing needed.

code	suitable for	mm
813096	810965 810989	540x440x(H)840



### CUTLERY TRAY

- 4 sections
- GN 1/1



code	colour	mm
552315	black	530x325x(H)100
552322	bordeaux	530x325x(H)100
552308	grey	530x325x(H)100



552315



552322



552308

### CUTLERY TRAY

- 6 sections
- Suitable for coffee spoons, teaspoons and cake forks
- GN 1/1



code	colour	mm
552353	grey	530x325x(H)105
552360	black	530x325x(H)105



552353



552360



552407

### CUTLERY BASKET HOLDER

- For 4 baskets
- Baskets not included



code	mm
552407	255x295x(H)215



552254



552261

### CUTLERY TRAY WITH STAND

- Set of cutlery tray and matching stand
- Gastronorm 1/1



code	sections	colour
552254	4 sections	grey
552261	6 sections	grey

### CUTLERY BASKET

code	mm
871201	Ø97x(H)137



### CUTLERY BASKET

code	mm
552490	Ø97x(H)137



871201



552490





## MELAMINE

- Hygienic and shock resistant.
- Light weight.

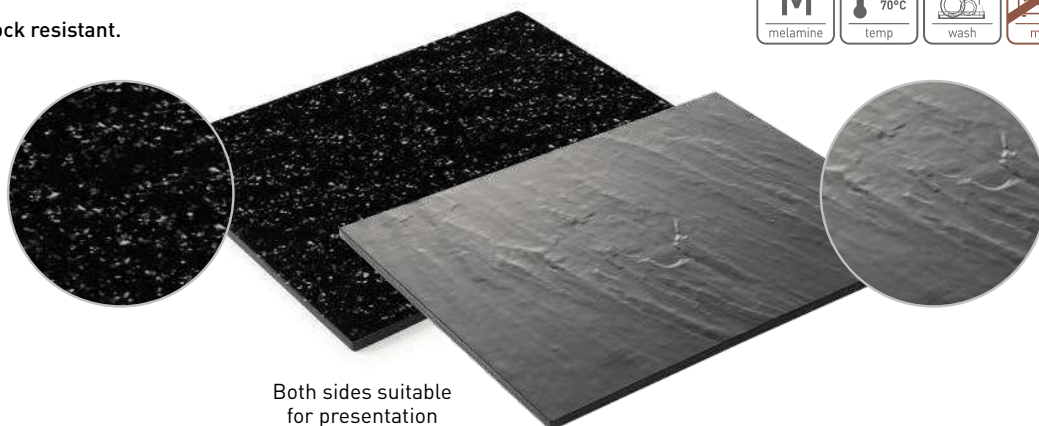

Both sides suitable for presentation



561379

561393



561409



561355

## PLATEAUS GN

- With slate appearance.
- One side with a textured slate appearance, other side with a smooth black granite appearance.

code		mm
561362	Gastronorm 1/1	530x325x(H)7
561379	Gastronorm 1/2	325x265x(H)7
561386	Gastronorm 1/3	325x175x(H)7
561393	Gastronorm 2/4	525x160x(H)7

## PLATEAUS ROUND

- With slate appearance.
- One side with a textured slate appearance, other side with a smooth black granite appearance.

code	mm
561409	Ø330x(H)7
561416	Ø430x(H)7

## PLATEAU ROUND WITH HANDLE

- With slate appearance.
- With non-slip feet.

code	mm
561355	424x300x(H)15





### PLATEAUS GN

- With wood appearance.
- With non-slip feet.

code		mm
561324	Gastronorm 1/1	530x325x(H)10
561331	Gastronorm 1/2	325x265x(H)10
561348	Gastronorm 2/4	525x160x(H)10



### PLATEAU ROUND WITH HANDLE

- With wood appearance.

code	mm
561300	424x300x(H)15



### PLATEAU RECTANGULAR WITH HANDLE

- With wood appearance.

code	mm
561317	530x200x(H)15



## MELAMINE

- Hygienic and shock resistant.
- Light weight.



Full range of bread baskets on page 375

Buffet and serving stand on page 388







Non slip display stands  
and melamine bowls  
on pages 388-389



566008



566015

#### GASTRONORM TRAYS WITH SLIM RIM

code		mm
566008	GN 1/1	530x325x(H)20
566015	GN 1/2	325x265x(H)20
566060	GN 1/2	325x265x(H)65
566022	GN 1/3	325x177x(H)20
566077	GN 1/3	325x177x(H)65
566046	GN 1/4	265x152x(H)20
566053	GN 2/4	530x163x(H)20



## MELAMINE BUFFET DISPLAY STANDS



561850  
561911



561898  
561928



561942  
561935

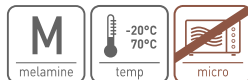

### MELAMINE CONTAINERS

- Melaminware is hygienic and shock resistant.
- Only for presentation.
- Not suitable for chafing dishes.

code		mm	height (mm)
561942	Container only	Ø120	110
561850	Container only	GN 1/3 - 325x176	100
561898	Container only	GN 1/6 - 176x162	100

### BUFFET DISPLAY STANDS

- Space saving and elegant solution for diverse condiments on buffets or in the kitchen.
- Chrome plated frame, easy to assemble.
- The included melamine containers are hygienic and light.
- Gastronorm models are suitable for HENDI Polycarbonate Gastronorm lids.

code	size	mm
561935	stand + 3x1L	193x540x(H)270
561911	stand + 3xGN1/3	360x570x(H)270
561928	stand + 3xGN1/6	207x570x(H)265





## MELAMINE

- Hygienic and shock resistant.
- Light weight.

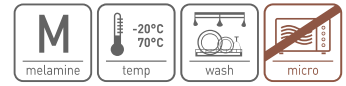

561607

### TABLET GN 1/1

code	mm
561607	530x325x(H)20



### PLATTER RECTANGULAR

code	mm
561508	360x205x(H)38
561515	495x270x(H)56
561522	560x320x(H)52



561591

### PASTA BOWL ROUND

code	mm
561591	Ø380x(H)90



### PLATE SQUARE

code	mm
561539	305x305x(H)40
561553	405x405x(H)50

### BUFFET DISH OVAL

code	mm
561645	610x230x(H)42

561645



561652



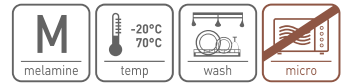

561584

561560

**BOWL SQUARE**

code	mm
561560	130x130x(H)65
561577	190x190x(H)100
561584	270x270x(H)105



561294

**BUFFET AND SERVING STAND**

- Bamboo stand with 3 melamine bowls.

code	mm
561294	400x130x(H)60

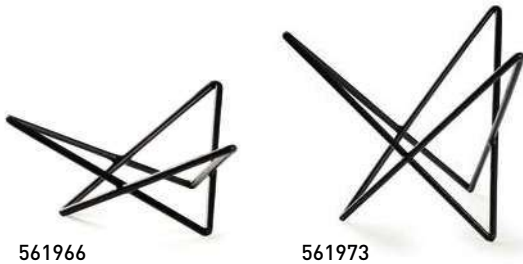

561966

561973

**NON-SLIP DISPLAY STANDS**

- Steel frame with PVC coating.  
- Supports a variety of display trays and bowls.

code	mm
561966	260x230x(H)100
561973	265x230x(H)200



561980

561997

**NON-SLIP DISPLAY STANDS**

- Steel frame with PVC coating.  
- Supports a variety of display trays and bowls.

code		mm
561980	round	Ø200x(H)100
561997	round	Ø200x(H)200



### CURVED PLATEAUS

- Hygienic and shock resistant.
- Light weight.

code	size	mm	height (mm)
561669	GN 1/1	530x325	40
561676	GN 1/2	325x265	40



561669

### CURVED BOWLS

- Hygienic and shock resistant.
- Light weight.

code	size	mm
561454	white	250x120x(H)75
561485	white	530x270x(H)107



561485



561461

### CURVED BOWLS

- Hygienic and shock resistant.
- Light weight.

code	size	mm
561461	white	315x310x(H)123
561478	black	315x310x(H)123



561478

### SLANTED BOWLS

- Hygienic and shock resistant.
- Light weight.

code	size	mm
561423		212x208x(H)104
561430		300x291x(H)137
561447		360x349x(H)163



561423





## PORCELAIN

- Special porcelain type, toughest type available.
- Thermal shock resistant, can withstand extreme temperature changes.
- High-impact and wear resistance and still relatively light-weight.
- Extremely pure and brilliant white.



783009

### GASTRONORM PAN GN 1/1

code		mm
783009	GN 1/1	530x325x(H)65



783016

### GASTRONORM PAN GN 1/2

code		mm
783016	GN 1/2	325x265x(H)65



783023

### GASTRONORM PAN GN 1/3

code		mm
783023	GN 1/3	325x176x(H)65



785003

785010

### DRESSING POT

code	ml
785003	1800
785010	1000



## FAST FOOD TRAYS

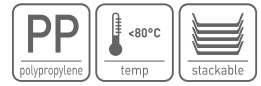

### FAST FOOD TRAYS MEDIUM

code	colour	mm
878903	grey	305x415
878910	red	305x415
878927	blue	305x415
878934	green	305x415
878941	brown	305x415
878958	black	305x415

### FAST FOOD TRAYS LARGE

code	colour	mm
878804	grey	350x450
878811	red	350x450
878828	blue	350x450
878835	green	350x450
878842	brown	350x450
878859	black	350x450

### FAST FOOD TRAYS SMALL

code	colour	mm
878705	grey	265x345
878712	red	265x345
878729	blue	265x345
878736	green	265x345
878743	brown	265x345
878750	black	265x345



Space between trays  
for better air circulation

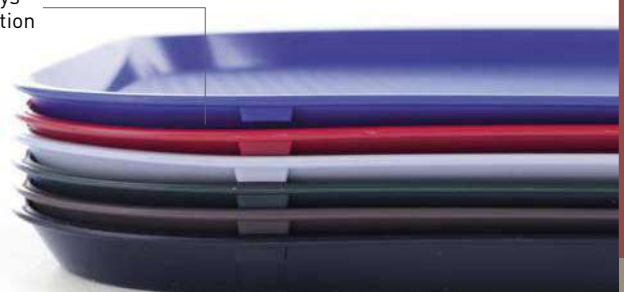
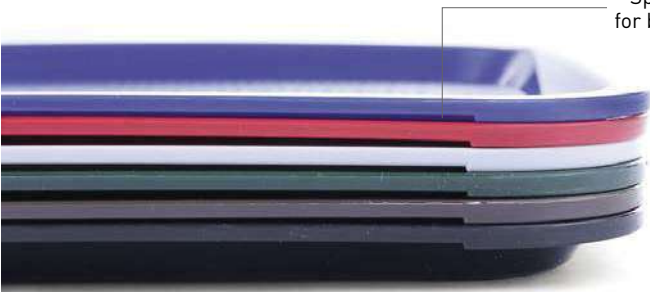

## GRANITE FORM



876602



### SERVING TRAY RECTANGULAR

- 'Granite' colour pattern.
- Professional grade quality, high durability.
- Ideal for self-service restaurants and canteens.

code		mm
876619	GN 1/1	530x325
876602	GN 1/2	265x325

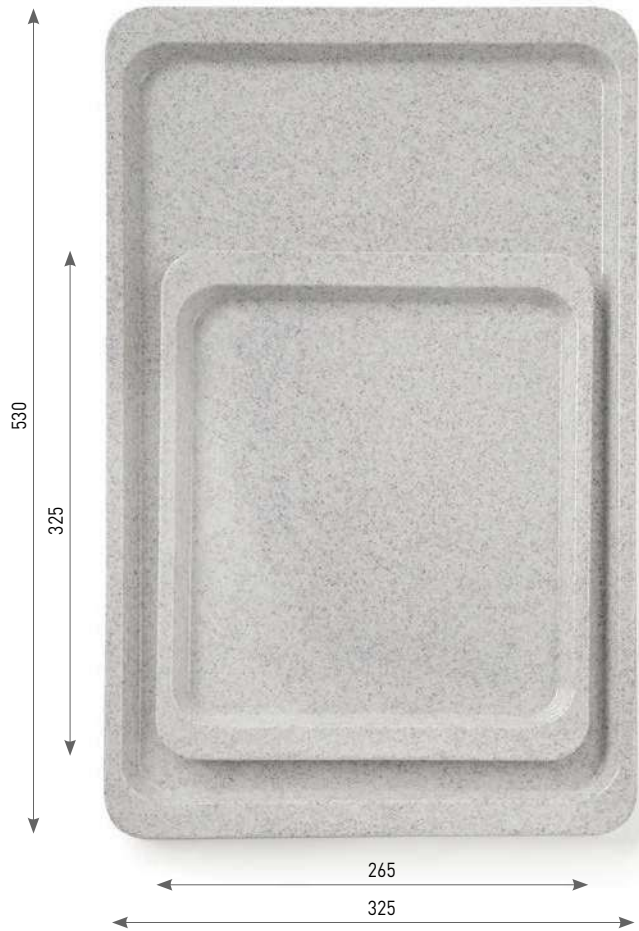

Distance between trays for better air circulation



876619



878507



878552

### FAST FOOD TRAYS OVAL

**NEW!**

code	colour	mm
878507	grey	265x195
878552	black	265x195





## WOOD FORM

- Mahogany colour.
- Wood reinforced laminate with non-slip layer.
- Shockproof, break resistant.



507216

### SERVING TRAY WOOD FORM

- Rectangular

code	
507216	GN 1/1
507117	Euronorm
507018	430x610
507469	330x430



507865

### SERVING TRAY WOOD FORM

- Round, with low rim

code	mm
507865	Ø380



507933



507568



507711

### SERVING TRAY WOOD FORM

- Oval

code	mm
507568	200x265
507964	230x160
507933	290x210

### SERVING TRAY WOOD FORM

- Round, with high rim

code	mm
507711	Ø320x(H)35
507766	Ø360x(H)30
507773	Ø420x(H)30

## POLYPROPYLENE

- Non-slip rubber surface, effective both wet and dry.
- Shockproof, break resistant



878101



878125



878606

### SERVING TRAY RECTANGULAR

- Black

code	mm
878118	255x355
878101	GN 1/1

### SERVING TRAY ROUND

- Black

code	mm
878125	Ø280
878132	Ø360
878149	Ø410

### SERVING TRAY ROUND WITH HIGH RIM

- Black

code	mm
878606	Ø320
878408	Ø360





## FIBREGLASS

- Fibreglass reinforced polyester.
- Ideal for heavy use scenarios.
- Non-slip rubber surface, effective both wet and dry.
- Shockproof, break resistant.



508657



508817



508718

### SERVING TRAY RECTANGULAR

- Black

code		mm
508657		200x280
508626	GN 1/1	325x530
508619	Euronorm	370x530

### SERVING TRAY ROUND

- Black

code	mm
508824	Ø280
508817	Ø350
508800	Ø400
508794	Ø460

### SERVING TRAY OVAL

- Black

code	mm
508718	160x230
508725	200x265
508732	210x290



508831



### SERVING TRAY OVAL XL

- Black.

code	mm
508831	735x600



810507



### FOLDING TRAY STAND

- High quality materials, sturdy construction.
- Fitted with black belts, easy to set up.

code	mm
810507	520x410x(H)800





### MELAMINE SERVING TRAY WITH WOOD PRINT

- Made of melamine, printed with a wood pattern.
- Excellent resistance to chemicals, stains and scratches.
- Available with 3 different stylish patterns.



code	colour	mm
508909	light oak	240x350
508916	brown oak	240x350
508923	dark oak	240x350
508930	light oak	370x530
508947	brown oak	370x530
508954	dark oak	370x530





TRAY STAINLESS STEEL



Full range of presentation covers on page 366

436103



436103

**SERVING TRAY GN 1/1**  
- Mirror with matt rim



code	mm
436103	530x325x(H)13



807705

**TRAY GN 1/1**



code	mm
807705	GN 1/1 530x325x(H)10



807804

**TRAY RECTANGULAR**  
- With decorated rim



code	mm
807804	GN 1/1 530x325





## SERVING DISH OVAL



code	mm
404003	190x140
404102	240x170
404201	300x220
404300	350x240
404409	400x260
404508	450x290
404607	500x350



## SERVING TRAY - Brushed



code	mm
480205	Ø300
480304	Ø350
480403	Ø400



## PARTY TRAY



code		mm
496206	oval	455x340
496305	round	Ø350
496404	GN 1/1	530x325
496107	rectangular	410x310



496206



496404

496107



496305



405000



421291



480106

## COFFEE TRAY OVAL - Satin finish



code	mm
405000	200x140
405208	265x195
405307	285x220

## COFFEE TRAY - DECORATED - Chrome-plated/nickel-plated iron



code	mm
421291	310x230

## BEER TRAY



code	mm
480106	Ø315x(H)45



## GREEN FIRE

- Much less sensitive to wind thanks to the improved air supply
- Easy to clean, due to e.g. fully removable burners and removable Gastronorm 2/1 dripping tray.
- Improved burners grant 90% of the surface useful heat.
- Technical parts mounted out of sight.
- Very clean burning, low CO emissions.
- Removable legs.



149508

### GREEN FIRE WITH 2 BURNERS

- Supplied with wind screen.
- Elevated stainless steel grid for keeping warm sauces and finished food.
- Gas hose with quick connector fitting to the barbecue. Gas hose and regulator attach to gas bottle - improved portability.

code		kW	mm
149508	Enamelled cast iron Gastronorm 1/1 griddle and grid	11,6	740x612x(H)825



149621

### GREEN FIRE WITH 2 BURNERS

- Supplied with wind screen.
- Elevated stainless steel grid for keeping warm sauces and finished food.
- Gas hose with quick connector fitting to the barbecue. Gas hose and regulator attach to gas bottle - improved portability.

code		kW	mm
149621	2 Stainless steel Gastronorm 1/1 barbecue grids	11,6	740x612x(H)825







149591

### GREEN FIRE WITH 3 BURNERS

- Enamelled cast iron griddle and 2 Gastronorm 1/1 grids included.
- Supplied with wind screen.
- Elevated stainless steel grid for keeping warm sauces and finished food.
- Gas hose with quick connector fitting to the barbecue. Gas hose and regulator attach to gas bottle - improved portability.

code	kW	mm
149591	17,4	1078x612x(H)825



149607

### GREEN FIRE WITH 4 BURNERS

- 2 Enamelled cast iron griddles and 2 Gastronorm 1/1 grids included.
- Supplied with wind screen.
- Elevated stainless steel grid for keeping warm sauces and finished food.
- Gas hose with quick connector fitting to the barbecue. Gas hose and regulator attach to gas bottle - improved portability.

code	kW	mm
149607	22	1400x612x(H)825



149614

### GREEN FIRE WITH 4 BURNERS

- 2 Enamelled cast iron griddles and 2 Gastronorm 1/1 grids included.
- Supplied with wind screen.
- Elevated stainless steel grid for keeping warm sauces and finished food.
- Gas hose with quick connector fitting to the barbecue. Gas hose and regulator attach to gas bottle - improved portability.

code	kW	mm
149614	on wheeled base	22 1400x612x(H)825





## GREEN FIRE ACCESSORIES



149515

### ROLLTOP HOOD FOR GREEN FIRE WITH 2 BURNERS

- With integrated thermometer.  
- Suitable for: 149508, 149621.



code	mm
149515	706x685x(H)239



144930

### PROTECTIVE COVER

- Made of UV-resistant PEVA.

code	suitable for	mm
144930	Green Fire 2 burner 149508 149621	745x615x(H)355



149539

### REAR TABLE FOR GREEN FIRE BARBECUES

- Suitable for: 149508, 149621, 149607, 149614.  
- Rear top 149539 is half as wide as the Green Fire with 4 burners. Two of these make one full-width rear top for the Green Fire with 4 burners.

code	mm
149539	rear table 650x298x(H)160



149522

149522

### SIDE TABLE FOR GREEN FIRE BARBECUES

- Suitable for: 149508, 149591, 149607, 149614, 149621

code	mm
149522	480x298x(H)160



626504

149546

### WOK

- With handles, sheet steel 1.5 mm thick.  
- Especially suitable for stainless steel wok holder 149546 with Green Fire barbecues, and in combination with stainless steel ring 147207 and Hokker 147108.

code	mm
626504	Ø700x(H)235



149553

### WOK HOLDER

- Suitable for all Green Fire Profi Line barbecues.

code	mm
149546	



### DUTCH PANCAKE GRIDDLE

- Suitable for all Green Fire Profi Line barbecues.

code	mm
149553	GN 2/1



side with groove



932001

ribbed side



932018

### CAST IRON GRIDDLE

- Suitable for all Green Fire Profi Line barbecues.

code		mm
932001	GN 1/1	325x530

### CAST IRON GRID

- Suitable for all Green Fire Profi Line barbecues.

code		mm
932018	GN 1/1	325x530



939949



939956



145777



### GRID & FLAME TAMER

- Place the flame tamer over the burner element to prevent fat dripping directly on the burner element.
- Chrome plated grid.
- Flame tamer made of stainless steel.
- Suitable for all Green Fire Profi Line barbecues.

code		mm
939949	Grid GN 1/1	325x530
939956	Flame tamer GN 2/1	650x530

### LAVA ROCK GRID

- Supplied with lava rocks.
- Suitable for all Green Fire Profi Line barbecues.

code		mm
145777	GN 1/1	535x330x(H)68



152706



152805

### LAVA ROCKS - FINE

- Suitable for various types of gas barbecues.
- Fine, relatively small rocks.

code	packed per
152706	3 kg in box

### LAVA ROCKS - COARSE

- Suitable for various types of gas barbecues.
- Coarse, relatively large rocks.

code	packed per
152805	5 kg in box
152904	9 kg in bag





154601

**BAKE-MASTER MINI**

- Frame made of 18/0 stainless steel.
- With enamelled frying pan.
- Inner dimensions of frying pan 290x480 mm.
- Electronic ignition and thermocouple.
- Gas hose and pressure regulator included.
- Suitable for propane and butane gas.
- Consumption 0,215 m³/h.

code	Power kW [Hs]	mm
154601	5,8	340x540x(H)300



154618

**BAKE-MASTER MAXI**

- Frame made of 18/0 stainless steel.
- With enamelled frying pan.
- Inner dimensions of frying pan 590x480 mm.
- Electronic ignition and thermocouple.
- Gas hose and pressure regulator included.
- Suitable for propane and butane gas.
- Consumption 0,430 m³/h.

code	Power kW [Hs]	mm
154618	11,6	650x540x(H)300



154656

**ENAMELLED FRYING PAN**

- Inner dimensions: 590x480 mm.



code	mm
154656	650x540



145531

**LAVA ROCK GRID**

- For Grill-Master Maxi.
- Supplied with lava rocks.



code	mm
145531	630x500



144923

**PROTECTIVE COVER**

- Made of UV-resistant PEVA.

code	suitable for	mm
144923	Grill- & Roast-Master Maxi 154717 154878	720x560x(H)360







Enamelled frying pan included



154717

**GRILL-MASTER MAXI**

- Frame made of 18/0 stainless steel.
- With chrome plated grid and enamelled frying pan.
- Inner dimensions of frying pan 590x480 mm.
- Electronic ignition and thermocouple.
- Gas hose and pressure regulator included.
- Suitable for propane and butane gas.
- Consumption 0,430 m³/h.

code	Power kW [Hs]	mm
154717	11,6	650x540x(H)840



154878

**ROAST-MASTER HEAVY DUTY**

- With chrome plated grid and heavy duty flame tamer.
- Frame and flame tamer made of 18/0 stainless steel.
- Electronic ignition and thermocouple.
- Gas hose and pressure regulator included.
- Suitable for propane or butane gas.
- Consumption 0,430 m³/h.

code	Power kW [Hs]	mm
154878	11,6	650x540x(H)840



154700

**GRILL-MASTER MINI**

- Frame made of 18/0 stainless steel.
- With chrome plated grid and enamelled frying pan.
- Inner dimensions of frying pan 290x480 mm.
- Electronic ignition and thermocouple.
- Gas hose and pressure regulator included.
- Suitable for propane and butane gas.
- Consumption 0,215 m³/h.

code	Power kW [Hs]	mm
154700	5,8	340x540x(H)840

Enamelled frying pan included



154908

**GRILL-MASTER QUATTRO**

- Fully stainless steel frame with 2 dripping trays.
- Suitable for propane and butane gas and fitted with 4 burners which can be regulated independently.
- Supplied with 2 nickel-plated grids and 1 enamelled griddle (590x480 mm internal dimensions).
- Thermocouple and electronic ignition.
- Gas hose and pressure regulator included.
- Consumption 0,8 m³/h.
- On a base with bottom shelf and 4 wheels for easy moving.

code	Power kW [Hs]	mm
154908	22	1270x525x(H)840



FOR GRILLING  
PERFECT STEAKS

18/0  
stainless steel

outdoor



148105

**XENON PRO**

- This stainless steel power grill with folding base is easy to move thanks to its wheels and can be flat-packed into a compact unit during transport.
- The burner develops a high temperature in the windproof unit and therefore this barbecue is suitable for high volume production.
- The unit itself is easy to clean thanks to these high temperatures.
- The grill is fitted with a thermocouple and electronic ignition, gas hose and pressure regulator are included.
- Suitable for propane gas.
- Grid surface area 860x260 mm (2 grids of 430x260 mm).
- Folding and mobile base.
- Gas hose, electronic ignition and pressure regulator included.
- Consumption 536 g/h.

code	Power kW [Hs]	mm
148105	7,5	1120x410x(H)900



148143

**SIDE TOP FOR XENON-PRO**

18/0  
stainless steel

code	mm
148143	870x(H)180





146002



146804

**FIESTA 600**

- Stainless steel base and sheet steel paella pan Ø 600 mm.
- Includes gas hose, electronic ignition and pressure regulator.
- With thermocouple and a round burner.
- Burner unit can be removed for easy cleaning.
- The space underneath is suitable for gas cylinders of 5 or 6 kg.
- Suitable for propane gas, consumption 334 g/h.

code	suitable for	Power kW [Hs]	mm
146002	622407	4,8	600x600x(H)870

**FIESTA 800**

- Stainless steel base and sheet steel paella pan Ø 800 mm.
- Includes gas hose, electronic ignition and pressure regulator.
- With thermocouple and a round burner.
- Burner unit can be removed for easy cleaning.
- The space underneath is suitable for gas cylinders of 5 or 11 kg.
- Suitable for propane gas, consumption 489 g/h.

code	suitable for	Power kW [Hs]	mm
146804	622605	7,0	800x800x(H)900



622407



**PAELLA PAN**

- Top-quality frying pans made of sheet steel
- With two handles

code	suitable for	mm
622407	146002	Ø600x(H)40
622605	146804	Ø800x(H)50





## CHARCOAL BARBECUES

– 18/0 stainless steel with removable stands.



150603



150801

### CHARCOAL BARBECUE PATIO

– Model Patio  
– Fitted with 2 grids of 345x345 mm each

code	mm
150603	770x380x(H)760

### CHARCOAL BARBECUE RESTO

– Model Resto  
– Fitted with 3 grids of 345x345 mm each

code	mm
150801	1145x380x(H)770

## BARBECUE ACCESSORIES



855218

855201



170045

18/0  
stainless steel

### BARBECUE SKEWERS

code	packed per	length (mm)
170045	24	210

### GRIDDLE SCRAPER

code	mm
855201	100x315

### SPARE BLADE FOR 855201

– 5 pieces

code
855218



170328

170120

18/0  
stainless steel  
wash

### BARBECUE SKEWERS

code	packed per	length (mm)
170120	6	250
170328	6	350



525517

### WIRE BRUSH

– Wood with four rows of wire.



code	per 2 on card	mm
525517		290



525418

### WIRE BRUSH

– Polypropylene with 8 rows of steel wire.  
– Steel scraper for grids.



code	mm
525418	70x190x(H)80

## OVEN MITTS

- Certified protective gloves. CE compliant in accordance with the Personal Protective Equipment Directive 89/686/EEC.



556603



### OVEN MITTS, COTTON

code	packed per	mm
556603	2	345



556627



### OVEN MITTS, FIBERGLASS

code	packed per	mm
556627	2	430



556610



### OVEN MITTS, FLAME RETARDANT COTTON

- Extra long to protect the forearm

code	packed per	mm
556610	cotton with flame retardant coating	430



556634



### OVEN GLOVE HEAT RESISTANT

- Heat resistant up to 350°C.

- Comfortable fit.

code	packed per	mm
556634	2	300



556696



**NEW!**

556658

### OVEN MITTS LEATHER

- Made from cow leather.

- Extra long to protect the forearm.

code	packed per	mm
556658	2	460

### BARBECUE APRON

- Canvas 280 g/m<sup>2</sup>.

- Flame retardant coating.

code	mm
556696	810x660



## PATIO HEATER



272602

### PATIO HEATER

- Suitable for propane or butane gas
- Easy to transport thanks to its 2 wheels
- Including electronic ignition, gas hose and pressure regulator
- With anti-tilt protection
- Consumption: 785 g/h

code	Power kW [Hs]	ØxH mm
272602	12,7	770x2200
144916	protective cover	Ø790x(H)2220

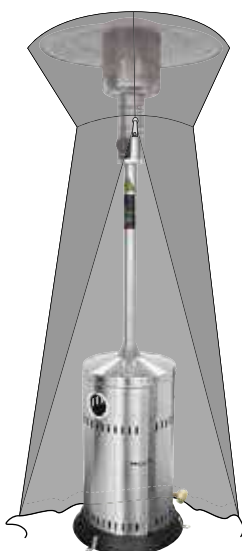

144916



272701

### PATIO HEATER - RETRACTABLE

- Suitable for propane or butane gas.
- Easy to transport thanks to its 2 wheels.
- Retractable shaft to facilitate transport and storage.
- Including electronic ignition, gas hose and pressure regulator.
- With anti-tilt protection.
- Retractable to (H)160 cm for storage and transport purposes.
- Consumption: 1048 g/h.

code	Power kW [Hs]	ØxH mm
272701	12,7	770x1580-2200
144916	protective cover	Ø790x(H)2220





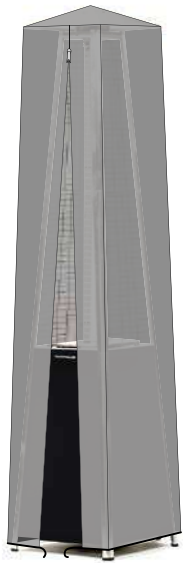

144909

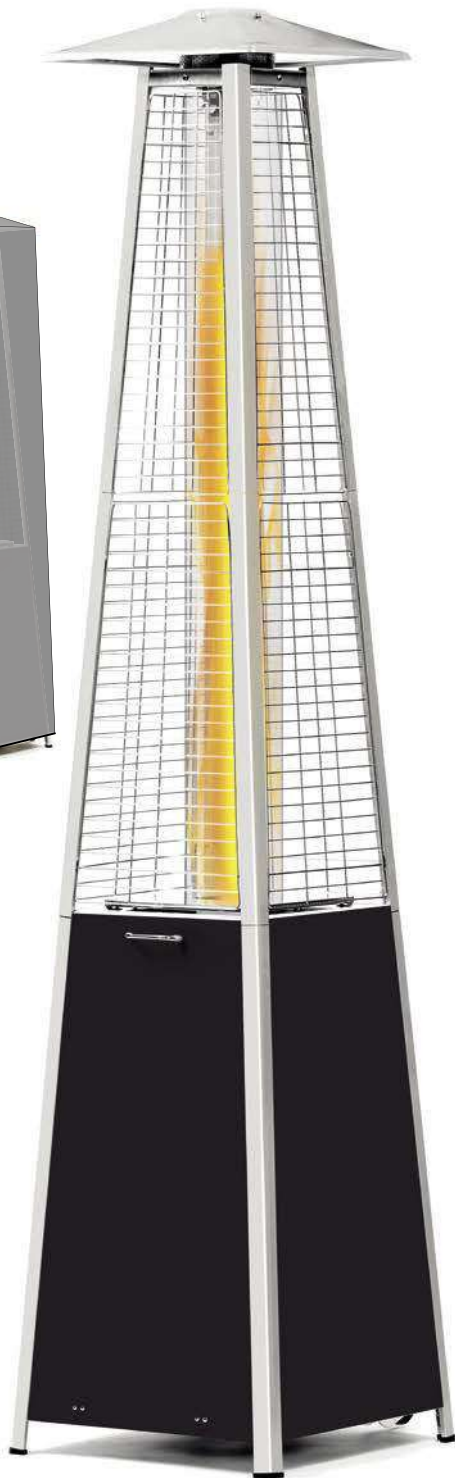

272404

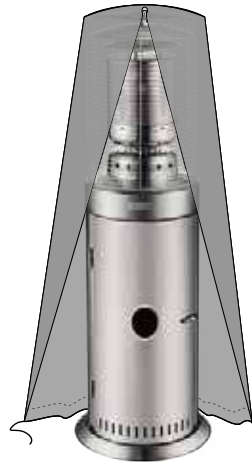

144954



272411

### PATIO HEATER PYRAMID

- Heating with a real flame in a glass tube, improves ambiance.
- Aluminium structure with black metal side panels and quartz glass tube.
- Gas tank fits in the base.
- Includes electronic ignition, gas hose and pressure regulator.
- With anti-tilt protection.
- Suitable for propane or butane gas.

code	Power kW [Hs]	ØxH mm
272404	11,2	420x420x(H)2220
144909	protective cover	480x480x(H)2220

### LOUNGE HEATER

- Suitable for propane or butane gas, max. 15 liter gas bottles.
- Compact design with hinged door for easily replacing the gas bottle.
- With tilt switch, flame failure device and flame guard for enhanced safety.
- Including electronic ignition, gas hose and pressure regulator.
- Easy to transport thanks to the 2 wheels.

code	Power kW [Hs]	ØxH mm
272411	13,5	Ø556x(H)1430
144954	protective cover	Ø580x(H)1460



## GENERAL INFORMATION

This product is protected by copyright. Use for commercial activities is only allowed if the original context is left intact, unless explicit permission for adaptation is given in writing by the author. In all cases of (partial) reproduction HENDI BV is to be clearly credited as source. Because of our striving for continuous product development, we reserve the right to change a product's specification, price and appearance without prior warning. Printing and typesetting errors reserved. The printed colors of products in this catalogue may have a limited deviation from the physical product.

For more information see [www.hendi.eu](http://www.hendi.eu)



### LEGEND OF THE ICONS USED IN THIS CATALOGUE

	Energy saving product		Food Contact compliant		High density polyethylene
	HACCP compliant		Not Food Contact compliant		Low density polyethylene
<b>NEW!</b>	New product		Cooling		Polypropylene
	For indoor and outdoor use		Self-assembly		Expanded Polypropylene
	For indoor use only		Temperature resistance		Polycarbonate
	For outdoor use only		Temperature resistance range		ABS plastic
	Suitable for gas stoves		Aluminium		POM plastic
	Suitable for gas stoves only		Aluminium casting		Polyamide
	Suitable for electric stoves		Stainless steel		SAN plastic
	Suitable for ceramic stoves		Stainless steel 18/0		Hard polymer heat resistant
	Suitable for induction stoves		Stainless steel 18/8		Silicone
	Not suitable for induction stoves		Stainless steel 18/10		Plexiglas
	Microwave proof		German steel X50CrMoV15		BPA free – no Bisphenol A
	Not microwave proof		Carbon steel		Fiberglass
	Dishwasher proof		Tin plated		Melamine
	Not dishwasher proof		Chrome plated		Porcelain
	Suitable for use in ovens		Nickel plated		Non slip
	Stackable		Polyethylene		Magnetic

**CODE-BASED INDEX**

code	page	code	page	code	page	code	page	code	page	code	page	code	page	code	page
<b>1xxxxx</b>		193327	356	208380	289	223093	205	227398	145	233122	220	238608	171	270202	257
110126	15	193617	358	208533	290	223109	203	229002	162	233139	220	238905	178	270219	256
111420	357	193624	358	208618	289	223116	205	229019	162	233207	210	238912	178	270226	256
144909	409	193716	359	208625	288	223123	202	229026	163	233214	210	239186	151, 347	270233	256
144916	408	193761	359	208632	288	223130	204	229033	163	233221	217, 271	239193	151, 347	270240	256
144923	402	193938	359	208649	288	223215	203	230299	250	233238	214	239209	150	270257	257
144930	400	193952	359	208656	290	223222	205	230305	250	233245	217, 271	239216	161	271117	92
144954	409	194300	356	208670	288	223291	202	230312	251	233252	211	239230	150	271124	92
145531	402	194355	356	208687	288	223307	204	230442	254	233269	215	239278	147	271148	90
145777	401	195109	357	208694	289	223345	201	230459	254	233276	212	239285	147	271155	92
146002	405	195505	357	208724	289	223352	201	230688	282	233283	212	239292	147	271162	91
146804	405	195604	357	208731	288	223369	200	230695	283	233290	215	239315	150	271179	92
147108	142	196007	65	209202	165	223376	200	230718	281	233306	212	239322	149	271186	92
147207	142	198124	117	209301	165	223642	203, 205	231050	250	233320	212	239346	149	271209	91
147306	142	198209	117	209509	151	223659	202, 203,	231210	255	233337	212	239506	171	271216	91
147610	145	198216	116	209523	147		204, 205	231227	255	233344	223	239605	171	271223	90
147801	142	198223	117	209882	295	223666	202, 204	231234	255	233351	223	239681	148	271230	91
148105	404	198230	116	209899	295	224038	278	231265	254, 255	233375	212	239698	149	271247	92, 289
148143	404	199039	116, 145	209905	296	224076	155	231760	251	233382	223	239711	148	271308	90
149508	398	199046	117	209981	69, 297	224328	122	231777	251	233399	223	239766	148	271339	91
149515	400	199770	160	209998	69, 297	224335	122	231784	251	233412	219	239773	148	271346	90
149522	400	199787	160	210000	135	224342	123	231791	251	233443	212	239780	150	271407	91
149539	400	199800	160	210017	135	224359	123	231807	118	233450	212	239902	346	271513	272
149546	400	199824	160	210031	134	224373	121	231852	119	233467	212	240403	158	271520	272
149553	400	199831	160	210048	134	224380	123	232019	222	233610	214	240410	158	271551	268
149591	399	199848	160	210215	136	224397	122	232026	222	233627	214	240502	177	271568	268
149607	399	199855	160	210222	136	224403	54	232033	229	233634	214	240601	296	271575	268
149614	399	199862	160	210246	136	224410	54	232040	224	233641	215	240700	296	271773	269
149621	398	199893	160	210802	128	224670	198	232057	224	233658	215	261163	181	271780	269
150603	406	199961	97, 160	210819	129	224823	198	232064	224	233665	215	261200	180	271797	269
150801	406	199978	97, 160	210864	130	224830	190	232071	224	233672	213	261309	180	272404	409
152706	401	199985	97, 160	211106	292	224847	190	232118	221	233689	213	262214	181	272411	409
152805	401	<b>2xxxxx</b>		211205	292	225165	198	232125	221	233696	215	262801	181	272602	408
152904	401	201107	178	211243	296	225264	154	232132	221	233702	211	263501	172	272701	408
154601	402	201206	178	211250	296	225448	154	232149	221	233719	211	263600	172	273869	153
154618	402	201428	138	211267	291	225479	157	232163	231	233726	152	263655	172	273876	153
154656	402	201435	138	211304	292	225516	199	232170	231	233733	152	263662	172	273883	153
154700	403	201442	139	211403	294	225523	199	232187	231	233740	151	263709	173	273890	153
154717	403	203125	170	211502	294	225608	155	232194	231	233757	213	263808	173	273906	153
154878	403	203149	170	212004	179	225639	199	232699	224	233788	218	263907	173	273982	152
154908	403	203156	170	212103	179	225707	143	232781	227	233795	218	264119	175	273999	152
170045	406	203163	170	212127	179	225806	143	232798	227	233825	210	264201	175	274101	373
170120	406	203170	170	212134	179	225882	144	232804	226	233832	210	264300	175	274125	297
170328	406	204825	346	215012	168	225899	144	232811	226	233849	219	264409	175	274149	297
171028	70	204832	346	215029	168	225929	198	232842	229	233856	219	264607	174	274224	280
171127	70	204900	346	220306	193	226001	186	232859	228	233863	219	264706	174	274231	107
171301	70	205808	166	221044	275	226094	144	232873	228	233870	219	265000	177	274248	161
171318	70	205815	166	221082	274	226209	188	232880	227	233887	219	265109	130	280096	118
171325	70	205822	166	221099	276	226308	188	232897	227	233894	219	267240	187	280102	118
171417	70	205839	166	221204	277	226315	188	232903	225	233900	216, 270	267257	187	280126	118
171516	70	205846	166	221808	259	226339	189	232910	225	233917	216, 270	268506	176	280201	118
171615	363	205853	166	222140	121	226346	189	232927	225	233924	216, 270	268605	176	280218	118
171707	71	205914	169	222157	121	226353	189	232965	225	233931	216, 270	268704	176	280225	118
171752	71	207208	165	222164	121	226612	191	232972	225	233948	225	268735	176	280294	118
171806	71	207307	165	222553	57	226629	191	232989	225	233955	225	270028	256	280300	118
171837	71	207345	164	222560	57	226636	191	232996	225	233962	151	270066	257	280317	118
171844	71	207352	164	222614	59	226827	187	233009	250	233979	225	270073	256	280416	118
171851	71	207369	164	222652	59	226834	120	233016	250	233986	225	270080	256	280423	119
171875	71	207376	164	222676	59	226865	195	233023	250	233993	225	270134	257	280621	118
171882	71	208007	293	222829	124	226872	195	233030	250	234730	119	270141	257	280690	119
171899	71	208106	293	222836	124	226889	195	233047	250	234747	119	270158	258	281246	259
171905	71	208205	293	222843	124	226896	195	233054	250	234754	119	270165	258	281352	184
190036	357	208304	290	222997	156	227060	196	233061	251	234761	119	270172	258	281369	185
190401	357	208335	289	223031	201	227077	197	233108	220	238301	171	270189	256	281390	183
193310	356	208342	289	223086	203	227381	145	233115	220	238486	159	270196	256	281413	185



code	page	code	page	code	page	code	page	code	page	code	page	code	page	code	page
281444	184	425138	372	432136	329	461266	335	5xxxxx		509463	81	521403	86	535516	85
281451	183	425190	371	432143	329	462904	69	505007	39, 374	510001	80	521410	266	535523	85
281475	182	425206	280	434208	329	463000	354	505106	39, 374	510100	80	521502	86	540107	78
281482	182	425299	370	436103	396	463109	354	505205	39, 374	510209	80	521601	86	540305	78
281499	183	425343	371	440001	340	464809	354	505403	39, 374	510308	80	521809	86	540404	78
281710	184	425411	370	440100	340	465301	335	505502	39, 374	510407	80	523018	363	540503	78
282007	127	425428	370	440209	340	465318	335	505540	193	511503	80	523216	363	540602	78
282014	127	425435	370	440216	339	465325	335	505557	193	511602	80	523315	363	540701	78
282021	127	425466	368	440223	339	465332	335	505564	193	511701	80	523520	266	541104	78
282038	127	425473	368	440407	340	465349	335	505571	193	511718	81	523629	333	541203	78
282045	127	425503	328	440490	340	465356	335	505588	193	511725	81	523636	333	541302	78
282052	127	425602	328	440506	339	465363	335	505595	193	511732	81	523827	367	541500	78
282069	127	425701	328	440605	340	465370	334	505618	62	511749	81	523834	367	542200	79
282076	127	425763	372	440704	338	465387	335	505625	62	511756	81	523902	192, 367	542507	79
282090	132	425800	328	440803	340	466070	376	505632	62	512104	96, 110	523957	192, 367	542606	79
282113	131	425909	324	440858	340	466087	376	505649	62	512135	96, 110	524008	72	542705	79
282120	131	425916	324	440865	340	466117	376	505656	62	512142	96, 110	524039	72	547304	83
282137	132	425923	324	440872	340	466124	376	505663	62	512159	96, 110	525005	77	547502	83
282144	132	425930	324	440902	340	466131	376	505670	62	512166	96, 110	525142	77	550106	108
282151	132	425947	324	441107	337	468821	334	505687	62	512173	96, 110	525418	406	550113	108
282199	126	425954	324	441367	337	469385	336	505694	62	512203	96, 110	525517	406	550120	108
282229	126	425961	324	441466	337	469392	336	506011	62	512210	96, 110	525630	194	550205	108
282236	126	425978	324	441503	337	469408	336	506905	39	512227	96, 110	526101	79	550229	108
282243	126	425985	324	443002	58	469415	336	506912	39	512234	96, 110	526118	79	550304	108
282250	126	425992	324	444023	337	469422	336	507018	393	512302	96, 110	526200	79	550328	108
282267	126	426326	322	445815	330	469439	336	507117	393	513002	63	526309	79	550403	108
282304	126	426333	322	445822	330	469446	336	507216	393	513019	63	527108	79	550427	108
282359	126	426340	322	445839	330	469453	336	507469	393	513026	131	527207	79	550502	108
282571	132	426357	322	445877	331	469460	336	507568	393	513033	131	527306	79	550526	108
282588	132	426364	322	445891	331	469477	336	507711	393	513538	62	528105	79	551011	109
4xxxxx		426371	322	445907	290	469484	336	507766	393	513545	62	528204	79	551110	109
400203	337	426388	322	446508	330	469491	336	507773	393	513552	62	529003	361	551202	109
401002	329	426395	322	446522	330	470084	347	507865	393	513569	62	529010	361	551400	109
401101	329	426418	328	446607	330	470091	347	507933	393	513705	56	529027	361	551417	109
401200	329	426425	318	446621	330	470190	354	507964	393	513712	56	529034	361	551592	109
402023	303	426432	318	446706	330	470206	355	508107	233	515006	115	529041	361	551691	109
402221	303	426449	318	446720	330	470213	353	508206	233	515013	115	529058	360	551790	109
402528	303	426456	318	448908	331	470220	353	508305	233	515020	115	529065	360	551806	93
403709	303	426463	322	449608	331	470237	353	508503	15	515037	115	529072	360	551813	93
403716	303	426470	322	450109	332	470244	353	508510	15	515044	112	529089	360	552001	253
404003	397	426487	322	450208	332	470251	351	508527	15	515105	55	529096	360	552100	285
404102	397	426500	328	450307	332	470268	351	508619	394	515228	111	529102	361	552131	285
404201	397	426609	328	450406	332	470275	351	508626	394	515327	111	529201	361	552254	381
404300	397	426708	328	450505	332	470282	351	508657	394	515358	111	529300	361	552261	381
404409	397	426807	328	451007	332	470305	355	508718	394	515365	111	529409	361	552308	381
404508	397	426906	328	451106	332	470312	355	508725	394	515389	111	530108	82	552315	381
404607	397	426951	375	451502	332	470527	356	508732	394	515396	111	530207	82	552322	381
405000	397	426968	375	451519	332	470619	348	508794	394	515501	82	530306	82	552353	381
405208	397	427415	366	451526	332	470909	354	508800	394	516102	86	530405	82	552360	381
405307	397	427507	366	451533	332	470930	354	508817	394	516201	86	530504	82	552407	381
407202	233	427514	367	452103	334	471005	349	508824	394	516300	86	530603	82	552490	381
407400	233	427538	366	452202	334	471050	349	508831	394	516676	68	530702	82	552681	286
408308	233	428245	289, 376	452325	333	471500	266	508909	395	516683	68	532003	81	553404	112
421291	397	428511	337	452400	334	471524	266	508916	395	516690	68	532102	81	554166	112
421550	338	428528	337	452424	334	472507	348	508923	395	516706	68	532201	81	554364	112
421574	338	429006	327	452714	333	472613	348	508930	395	516713	68	532300	81	554432	112
424001	367	429013	327	453001	332	475201	348	508947	395	516720	68	535103	85	556603	209, 407
424155	364	429020	327	453100	332	475904	348	508954	395	516737	68	535202	85	556610	209, 407
424186	364	429037	327	453209	332	480106	397	509005	80	516744	68	535271	85, 322	556627	209, 407
424193	364	429044	327	453308	332	480205	397	509012	80	517109	82	535288	85, 322	556634	209, 407
424629	327	429051	327	453407	332	480304	397	509104	80	517208	82	535295	85, 322	556641	53
424636	327	429211	327	456514	333	480403	397	509203	80	517307	82	535301	85	556658	209, 407
424643	327	429228	327	458006	332	480502	369	509302	80	517406	82	535400	85	556696	407
424650	327	429419	233	458204	332	480519	369	509401	80	517604	82	535417	85	556719	68
424667	327	429914	368	458211	332	496107	397	509418	81	518519	110	535424	85	557105	108
424681	327	430002	329	458228	332	496206	397	509425	81	518533	110	535431	85	557112	108
424698	327	432006	329	460245	334	496305	397	509432	81	518700	69	535448	85	557303	108
425107	372	432105	329	460252	334	496404	397	509449	81	521205	86	535455	85	557402	371
425121	372	432129	329	461167	335			509456	81	521304	86	535509	85	557600	279

code	page	code	page	code	page	code	page	code	page	code	page	code	page	code	page
557617	279	561676	389	566909	369	593042	284	611609	9	622735	17, 321	635155	84	663486	341
557624	279	561706	325	567104	86	593066	284	611708	9	622742	17, 321	635209	84	663608	341
557631	279	561713	325	567203	86	593097	284	612002	9	622810	17, 321	635308	84	663615	341
557648	279	561720	325	567302	86	593103	265	612101	9	622827	17, 321	635407	84	663622	341
557808	94	561850	386	567401	86	593158	265	612200	9	622834	17, 321	635605	84	663639	341
557815	94	561898	386	567500	86	593165	266	612309	9	622841	17, 321	637104	84	663646	341
557822	94	561911	386	567616	69	593202	265	612408	9	622858	17, 321	637203	84	663653	341
557839	94	561928	386	567630	69	593608	265	612507	9	624302	69	637302	84	663660	341
557846	94	561935	386	567654	69	593806	265	613009	9	625002	16	637401	84	663691	341
557853	94	561942	386	567821	86	593813	265	613108	9	625057	16	637500	84	663707	341
557907	94	561966	388	567838	86	593905	265	613207	9	625101	16	637609	84	663745	341
557914	94	561973	388	567845	86	594704	266	613603	9	625606	16	637791	113	663783	341
557921	94	561980	388	567852	86	594742	266	613702	9	625705	16, 321	637807	113	663790	341
557938	94	561997	388	567906	372	594759	266	613801	9	625804	16, 321	637814	113	663806	341
557945	94	562000	86	568101	232	595008	337	617014	51, 192	626504	142, 400	637821	113	663820	341
557952	94	562017	86	568200	232	595206	338	617069	193	627600	12	637838	113	663844	341
557969	95	562079	86	568309	232	595305	338	617076	193	627617	12	637845	113	663851	341
557976	95	563007	77	568408	232	595572	264	617083	193	627624	12	638101	333	663868	341
557983	95	563106	77	568507	232	595589	264	617090	193	627631	12	638309	84	663875	341
558003	94	563205	77	568804	232	596715	284	617106	193	627648	12	638507	84	663882	341
558010	94	563304	73	569009	232	596722	284	617205	193	627655	12	638705	84	663899	341
558027	94	563311	73	569016	232	596739	284	617304	193	627662	12	638903	84	663950	258
558034	94	563328	73	569108	232	596746	262	617403	193	627679	12	639009	84	663998	258
558041	94	563335	73	569207	232	596753	284	617410	193	627686	12	639016	84	664001	342
558058	94	563342	73	569757	340	596760	285	617427	193	627716	12	639023	84	664018	342
558324	95	563359	73	570012	56	596777	285	617434	193	627730	12	640104	66	664025	342
558355	95	563366	73	570104	56	596807	262	617502	193	627747	12	640203	66	664032	342
558386	95	563373	73	570159	60	597200	262	617526	193	628591	14	640401	66	664049	342
558416	95	563380	73	570166	60	597316	262	617533	193	628607	14	640500	66	664056	343
558447	95	563502	362	570715	56	597323	262	617540	193	628614	14	640609	66	664063	343
558478	95	563557	362	570807	333	597507	262	617557	193	628621	14	640708	66	664070	343
559208	62	563632	362	570906	57	597958	286	617564	193	628638	14	640807	66	664087	343
560037	261	563649	362	572016	104	597965	286	617571	193	628706	14	640913	66	664094	343
560044	261	563700	362	572115	104	597972	286	617588	193	628713	14	640920	66	664100	342
561003	375	563755	362	572214	104	598016	264	617595	193	628805	14	642504	67	664117	342
561102	375	563908	362	572313	104	598047	38	617700	192	628850	14	642559	67	664209	343
561201	375	564004	362	572412	104	598214	264	617816	194	629109	11	642566	67	664216	343
561294	388	564103	362	572511	104	598313	264	617861	194	629130	10	642603	67	664223	343
561300	383	564158	362	572610	104	598412	264	619100	9	629154	10	643914	262	664230	343
561317	383	564202	362	572719	104	598719	264	619209	9	629208	11	646205	67	664247	343
561324	383	564400	362	580004	87	598818	264	619308	9	629253	10	646304	67	664254	343
561331	383	564455	362	580226	87	598955	287	621103	13	629307	11	646601	67	664261	343
561348	383	564509	326	580233	87	598962	287	621110	13	629345	10	647509	83	664278	343
561355	382	564516	326	580301	87	599013	264	621127	13	629352	11	647516	83	665121	287
561362	382	564523	326	582015	92	599112	264	621134	13	629390	11	647554	83	665138	287
561379	382	564530	326	582022	92	599198	264	621158	13	629413	11	647561	83	665145	287
561386	382	564547	326	586907	101	599211	264	621202	320	629505	11	647592	82	665152	287
561393	382	564554	326	588017	98	599372	263	621219	320	629604	11	657607	363	665169	287
561409	382	564561	325	588024	98	599402	263	621226	320	629802	11	657621	363	665251	338
561416	382	564578	325	588031	100	599419	263	621233	320	630006	64	658000	77	665381	287
561423	389	564585	325	588147	99	599426	263	621240	320	630105	65	658604	76	665503	338
561430	389	564592	325	588208	101	599433	263	621257	320	630136	65	658703	76	665510	338
561447	389	564608	325	588215	101	599440	263	621264	320	630204	65	658802	76	673416	111
561454	389	565360	287	588369	100	599457	263	621271	320	630235	65	658901	76	674413	111
561461	389	565605	325	588376	100	599464	263	621288	320	630303	64	659007	76	676202	114
561478	389	565612	325	588406	273	599471	263	621295	320	630402	61, 120	659014	76	676509	114
561485	389	565629	325	588420	100	599488	263	621301	320	630419	61, 120	659106	76	676707	114
561508	387	565636	325	588567	273	6xxxxx		621318	320	630648	94	659205	76	676806	114
561515	387	565643	325	588574	273	607015	323	621325	320	630716	64	659304	76	676905	114
561522	387	565650	325	589007	100	607022	323	621332	320	630808	64	659403	76	677001	114
561539	387	565667	325	589106	99	607039	323	621349	320	630907	319	659458	76	677209	114
561553	387	565674	325	589113	99	607046	323	621356	320	630914	319	659465	76	677308	114
561560	388	566008	385	589205	98	610107	9	622100	17	630921	319	659472	76	677506	114
561577	388	566015	385	592038	333	610206	9	622308	17	631102	334	659502	77	677810	113
561584	388	566022	385	592045	279	610305	9	622407	17, 405	631201	334	659601	77	677827	113
561591	387	566046	385	592052	279	611104	9	622605	17, 405	631300	334	659700	77	677834	113
561607	387	566053	385	592069	279	611302	9	622704	17, 321	632802	65	659809	77	678008	162
561645	387	566060	385	593004	284	611401	9	622711	17, 321	632901	65	663462	341	678015	162
561669	389	566077	385	593035	284	611500	9	622728	17, 321	635001	84	663479	341	678022	162

code	page	code	page	code	page	code	page	code	page	code	page	code	page	code	page
678107	319	721100	360	764510	299	785546	314	795101	305	800850	25	802519	21	806654	23
678114	319	721209	360	764527	299	785553	314	795309	305	800867	25	802526	21	806692	23
678121	319	721308	360	780008	311	785560	314	795507	305	800874	25	802533	21	806722	23
678138	319	721407	360	780015	311	785577	314	795705	305	801208	20	802540	21	806739	23
679005	267	722107	361	780022	311	785645	314, 318	795903	305	801215	20	802601	21	806814	23
679012	267	755006	102	780039	311	785652	314, 318	796306	305	801222	20	802618	21	806821	23
679029	267	755013	102	780046	311	785669	314	796405	305	801239	20	802625	21	806838	23
679036	267	755020	102	780053	311	785676	314	796603	305	801246	20	802632	21	806845	23
679043	267	755037	102	780060	311	785683	314	796702	305	801253	20	802649	21	806852	23
679050	267	755044	102	780077	311	785690	314	796801	305	801307	20	802656	21	806869	23
679067	267	755051	102	780084	311	785904	315	798010	305	801314	20	804001	23, 25	806876	23
680018	72	755068	102	780091	311	786239	316	798034	305	801321	20	804018	23, 25	806913	23
680025	72	755075	102	780107	311	786307	315	798164	305	801338	20	804025	23, 25	806920	23
680032	72	755082	102	780114	311	786321	315	798171	305	801345	20	804032	23, 25	806937	23
680049	72	755099	102	780121	311	786338	315	798249	305	801352	20	804049	23, 25	806944	23
680056	72	755105	102	780138	311	786345	315	798805	305	801406	21	804056	23, 25	806951	23
680063	72	755112	102	780145	311	786352	315	798904	305	801413	21	804100	21	806968	23
680070	72	755143	102	780152	311	786369	315	799147	313	801420	21	804117	21	806975	23
680087	72	755259	102	780169	311	786376	315	799154	313	801437	21	804124	21	807019	106
680094	72	755273	102	780176	311	786383	315	799161	313	801444	21	804131	21	807026	106
680100	72	755334	103	780183	311	786413	316, 334	799178	313	801451	21	804148	21	807033	106
680117	72	755341	103	780190	311	786420	316, 334	799383	313	801505	21	804155	21	807057	106
680124	72	755358	103	780206	311	786437	316	799390	313	801512	21	804162	21	807071	106
682104	110	755365	103	781302	43	786451	316	799406	313	801529	21	804179	21	807088	106
682302	110	755372	103	781319	42	786499	316	799413	313	801536	21	805107	21	807095	106
682401	110	755389	103	781326	43	787007	307	799420	313	801543	21	805114	21	807118	23
689608	110	755396	103	781333	43	787014	307	799437	313	801550	21	805121	21	807125	23
689806	110	755556	103	781340	42	787021	307	799444	313	801604	21	805138	21	807132	23
690000	56	755563	103	781357	42	787038	307	799451	313	801611	21	805145	21	807224	23
691021	261	755570	103	781364	43	787045	307	799468	313	801628	21	805152	21	807323	23
691120	261	755655	103	781371	42	787052	307	799475	313	801635	21	805534	208	807330	23
693001	55	755679	103	781388	43	787069	307	799482	313	801642	21	805541	208	807705	396
693100	55	755686	103	781395	43	787076	307	8xxxx		801659	21	805558	208	807804	396
693209	55	755693	103	781401	43	787083	307	800102	24	801666	20	806104	22	808108	23
693216	55	755730	105	781418	43, 45	787090	307	800119	24	801703	21	806111	22	808153	23
693223	55	755808	105	781432	302	787113	307	800126	24	801710	21	806128	22	808207	206
693254	55	755815	105	781449	302	787120	307	800133	24	801727	21	806135	22	808214	206
693261	55	755822	105	781456	302	787144	307	800140	24	801734	21	806142	22	808221	206
695708	272	755839	105	783009	390	787151	307	800157	24	801826	21	806159	22	808238	206
695906	278	759233	104	783016	390	787175	307	800218	24	801833	21	806197	23	808245	206
696002	286	759240	104	783023	390	787182	307	800225	24	801840	20	806203	22	808306	207
696040	286	759257	104	783153	117, 325	787267	307	800232	24	801857	20	806210	22	808313	208
696200	287	759264	104	783160	117, 325	794050	313	800249	24	801864	20	806227	22	808405	207
7xxxx		759301	105	783177	117, 325	794067	313	800300	24	801871	20	806234	22	808412	208
707661	244	764015	301	783627	117, 325	794074	313	800317	24	801901	207	806241	22	808429	207
707814	247	764022	301	783658	314	794081	313	800324	24	801918	207	806258	22	808474	207
707821	243, 245	764039	301	784006	315	794098	313	800331	24	801925	206	806296	23	808504	232
	247	764077	301	784013	315	794319	309	800348	24	801932	208	806302	22	808511	232
707845	243, 244	764084	301	784020	315	794326	309	800355	24	801956	207	806319	22	808566	232
707906	247	764091	301	784105	315	794333	309	800409	25	801963	206	806326	22	808573	232
707944	247	764138	301	784112	315	794340	309	800416	25	801970	196, 197	806333	22	809150	207
707951	247	764206	300	784129	315	794357	309	800423	25	801994	206	806340	22	809242	207
707968	247	764213	300	784327	317	794364	309	800430	25	802021	106	806357	22	809259	207
707975	247	764220	300	784334	317	794371	309	800447	25	802038	106	806395	23	809600	347
707982	246	764237	300	784365	317	794388	309	800454	25	802045	106	806401	23	809709	347
707999	245	764244	300	784372	317	794395	309	800522	25	802052	106	806418	23	810002	235
709818	194	764251	300	784389	317	794401	309	800539	25	802168	21	806425	23	810101	235
709825	194	764268	300	784396	317	794418	309	800546	25	802205	21	806432	23	810149	236
709900	194	764404	299	784419	317	794425	309	800553	25	802212	21	806449	23	810156	236
710104	248	764411	299	784426	317	794432	309	800621	25	802229	21	806456	23	810200	236
710203	248	764428	299	784433	317	794449	309	800638	25	802236	21	806494	23	810309	259
710302	248	764435	299	784730	314	794456	309	800645	25	802243	21	806524	23	810316	259
720103	360	764442	299	784747	314	794463	309	800652	25	802328	21	806531	23	810385	377
720400	360	764459	299	784754	314	794470	309	800720	25	802335	21	806548	23	810392	377
720509	360	764466	299	784761	314	794487	309	800737	25	802342	21	806555	23	810422	377
720608	360	764473	299	784778	314	794500	305	800812	25	802427	21	806593	23	810439	377
720806	360	764480	299	785003	390	794517	309	800829	25	802434	21	806623	23	810446	377
720905	360	764497	299	785010	390	794524	309	800836	25	802441	21	806630	23	810453	377
721001	360	764503	299	785324	317	794531	309	800843	25	802502	21	806647	23	810460	377



code	page	code	page	code	page	code	page	code	page	code	page	code	page	code	page
810477	377	825556	36	832837	8	842621	46	856031	50	862537	30	869635	26	877920	240
810484	377	825563	36	832844	8	842638	47	856048	50	862568	31	869666	27	877937	240
810491	377	825570	35, 36	832851	8	842645	47	856055	50	862575	31	869673	27	878101	393
810507	394	825600	36	832882	8	842652	48	856062	51	862582	31	869680	27	878118	393
810514	236	825617	36	832899	8	842669	46	856079	51	862612	30	869727	26	878125	393
810521	379	825624	36	833506	3	842676	35	856086	50	862629	30	869734	26	878132	393
810538	379	825631	36	834206	8	842706	45	856109	80	862636	30	869772	27	878149	393
810606	235	825648	36	834404	8	842713	48	856116	56	862674	31	869789	27	878408	393
810613	234	825655	36	834701	8	842720	46	856123	56	862681	31	869819	26	878507	392
810651	234	825662	35, 36	834909	8	842737	47	856147	55	862704	30	869826	26	878552	392
810668	234	826003	37	835104	8	842744	47	856154	51	862711	30	869833	26	878606	393
810705	249	826010	37	835401	5	842751	48	856178	51	862728	30	869840	26	878705	391
810712	249	826027	37	835432	5	842775	35	856185	50	862735	30	869857	26	878712	391
810729	249	826034	37	835500	5	842799	46	856192	51	862766	31	869864	26	878729	391
810736	249	826041	37	835531	5	842904	45	856208	52	862773	31	869918	26	878736	391
810743	249	826058	37	835609	5	842928	46	856215	52	862780	31	869925	26	878743	391
810897	378	826065	35, 37	835630	5	842966	46	856222	52	862827	30	869949	27	878750	391
810910	378	826102	37	836002	6	843000	45	856239	52	862902	30	869956	27	878804	391
810927	378	826119	37	836019	6	843055	48	856246	52	862919	31	869963	27	878811	391
810934	378	826126	37	836026	6	843109	45	856253	51	862926	30	869970	27	878828	391
810941	380	826133	37	836033	6	843154	48	856277	53	862933	30	869987	27	878835	391
810958	379	826140	37	836040	6	843451	63	856284	53	862940	30	869994	27	878842	391
810965	380	826157	37	836057	15	844205	40	856291	52	862957	30	871102	253	878859	391
810989	380	826164	35, 37	836101	6	844212	40	856307	53	862964	31	871201	381	878903	391
812204	237	826201	36	836200	6	844229	41	856314	53	862971	31	871300	253	878910	391
812266	238	826300	38	836309	6	844236	41	856321	58	862988	31	871324	253	878927	391
812273	239	826324	38	836408	6	844250	40	856338	58	862995	31	871331	253	878934	391
812280	239	826331	38	836507	6	844267	41	856345	58	864104	29	871348	253	878941	391
812372	238	826348	39, 285	837108	6	844274	41	856352	58	864128	29	871546	33	878958	391
813096	380	826355	39, 285	837207	6	844281	41	856369	58	864135	29	871706	365	880005	28
813157	379	826478	39, 285	837306	6	844298	41	856376	58	864142	29	871713	365	880012	28
813164	379	826485	39, 285	837405	6	844304	41	860083	345	864159	29	871805	365	880029	28
813171	379	826607	38	837603	6	844311	41	860304	345	864166	29	871812	365	880036	32, 34
813829	379	826614	38	838105	7	844328	41	860502	344	866009	366	876602	392	880050	32, 34
813836	379	826621	38	838204	7	844335	41	861202	29	868522	29	876619	392	880067	32, 34
813850	379	826638	38	838303	7	844342	41	861219	29	868546	29	877005	252	880074	32, 34
814352	378	826645	38	838501	7	844359	53	861226	29	868553	29	877012	252	880104	28
814369	378	826652	38	838600	7	844366	53	861233	29	868577	29	877029	252	880111	28
814376	378	826706	38	838617	7	844403	41	861400	29	869208	26	877036	252	880128	28
814383	378	826713	38	839003	15	844410	45	861417	29	869215	26	877043	252	880159	32, 34
814390	378	826720	38	839409	7	844427	45	861424	29	869222	26	877050	252	880166	32, 34
814406	378	826737	38	839997	7	844434	45	861431	29	869239	26	877104	252	880173	32, 34
814413	378	826744	38	841020	49	844441	45	861509	29	869260	27	877111	253	880203	28
814420	378	826751	38	841105	49	845028	44	861516	29	869277	27	877128	253	880210	28
814437	378	830000	4	841112	49	845035	44	861523	29	869284	27	877173	253	880227	28
814444	380	830048	4	841129	49	845042	44	861530	29	869307	26	877180	253	880258	33, 34
814451	380	830055	4	841136	49	845059	44	861608	29	869314	26	877197	253	880265	33, 34
814468	380	830154	4	841228	49	855119	74	861615	29	869321	26	877203	252	880272	33, 34
817148	25	830208	4	841235	49	855201	170, 406	861622	29	869338	26	877234	253	880289	33, 34
817155	25	830253	4	842003	49	855218	170, 406	861639	29	869369	27	877241	253	880302	28
817247	25	830352	5	842010	49	855508	74	861707	29	869376	27	877258	253	880319	28
817254	25	830376	5	842102	45	855607	74	861714	29	869383	27	877265	253	880326	28
817346	25	830406	4	842119	48	855652	74	861721	29	869406	26	877272	253	880357	33, 34
817353	25	830505	4	842171	35	855669	74	861738	29	869413	26	877289	253	880364	33, 34
817445	25	830604	4	842201	45	855676	74	861820	29	869420	26	877296	253	880371	33, 34
817452	25	831007	3	842218	48	855683	75	861837	29	869437	26	877500	252	880388	33, 34
817810	25	831205	3	842256	48	855690	75	862209	30	869468	27	877517	252	880401	28
817827	25	831403	3	842270	35	855706	75	862216	30	869475	27	877524	252	880418	28
817834	25	831502	3	842317	48	855713	74	862223	30	869482	27	877531	252	880425	28
817841	25	831601	3	842355	48	855720	74	862285	31	869505	26	877548	252	880456	33, 34
820209	43	831700	3	842409	45	855737	74	862407	30	869512	26	877814	243	880463	33, 34
820308	43	832004	2	842423	46	855744	75	862414	30	869529	26	877821	243	880470	33, 34
820407	43	832202	2	842478	35	855751	112	862421	30	869536	26	877845	242	880487	33, 34
820605	54	832400	2	842522	46	855768	51	862438	30	869567	27	877852	242	880524	28
820612	54	832509	2	842539	47	855775	75	862476	31	869574	27	877869	242	880555	33, 34
825518	36	832608	2	842546	47	855782	75	862483	31	869581	27	877876	242	880562	33, 34
825525	36	832707	2	842553	48	856000	50	862506	30	869604	26	877883	241	880609	28, 33
825532	36	832806	2	842607	45	856017	50	862513	30	869611	26	877906	241	880616	28, 33
825549	36	832820	8	842614	48	856024	50	862520	30	869628	26	877913	240	880623	28, 33

code	page	code	page	code	page	code	page	code	page	code	page	code	page	code	page
880630	28, 33	881712	35	9xxxxx		933350	129	943380	196, 197	970614	138	971055	141, 156	975398	137
880647	28, 33	881729	35	919200	153	933367	129	943489	281	970621	138	971062	140	975732	135
880654	28, 33	881736	35	919217	153	933688	281	970232	249	970638	140	971079	140	975749	135
880661	33	881743	35	931219	128	934012	121	970249	249	970652	137, 154	971314	137, 154	975756	135
880678	33	881750	35	931226	128	934029	123	970256	249	970669	137, 154	971321	137, 154	975770	44
880685	33	881804	28	931233	128	934159	257	970270	249	970676	137, 154	971338	137, 154	975800	135
880692	33	881811	28	931240	128	934166	257	970294	133	970683	137, 154	975251	137	980033	87
880869	33, 35	881828	28	931257	128	935286	258	970300	260	970690	137, 154	975268	137	980101	367
880906	192	890233	208	932001	401	939949	401	970362	141	971000	141, 156	975275	137		
880913	192	890240	208	932018	401	939956	401	970386	138	971017	141, 156	975305	125		
880920	192	890257	208	933329	129	942642	281	970393	138	971024	141, 156	975312	125		
880968	192	890349	208	933336	129	942758	278	970515	260	971031	141, 156	975329	125		
881705	35	890356	208	933343	129	942765	278	970607	138	971048	141, 156	975374	140		











# HENDI

## Tools for chefs | 2019

**Hendi B.V.**

Steenoven 21  
3911 TX Rhenen  
The Netherlands  
T: +31 317 681 040  
info@hendi.eu

**Hendi Polska Sp. z o.o.**

ul. Magazynowa 5  
62-023 Gądko  
Poland  
T: +48 61 658 7000  
info@hendi.pl

**Hendi Food Service Equipment GmbH**

Gewerbegebiet Ehring 15  
5112 Lamprechtshausen  
Austria  
T: +43 6274 200 10 0  
office.austria@hendi.eu

**Hendi Food Service Equipment Romania S.R.L.**

Str. 13 Decembrie 94A, Hala 14  
Braşov, 500164  
Romania  
T: +40 268 320 330  
office@hendi.ro

**Hendi UK Ltd.**

Central Barn, Hornby Road  
Lancaster, LA2 9JX  
United Kingdom  
T: +44 333 014 3200  
sales@hendi.co.uk

**Hendi HK Ltd.**

1208, 12/F Exchange Tower  
33 Wang Chiu Road, Kowloon Bay  
Hong Kong  
T: +852 2154 2618  
info-hk@hendi.eu

**PKS Hendi South East Europe SA**

5 Metsovou Str.  
18346 Moschato, Athens  
Greece  
T: +30 210 483 9700  
office.greece@hendi.eu

**Hendi Italia S.R.L.**

Boznerstrasse 63 - Via Bolzano, 63  
39057 Eppan a.d.W.-Appiano s.s.d.v.(BZ)  
Italy  
T: +39 338 491 4565  
office.italy@hendi.eu

Distributor

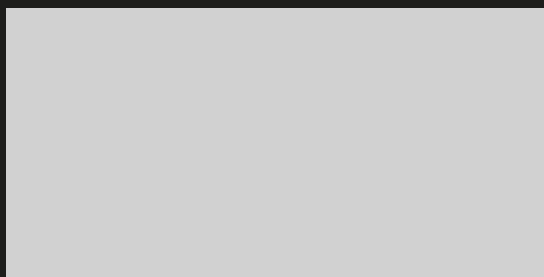

[www.hendi.eu](http://www.hendi.eu)