

# EKF 311 N UD

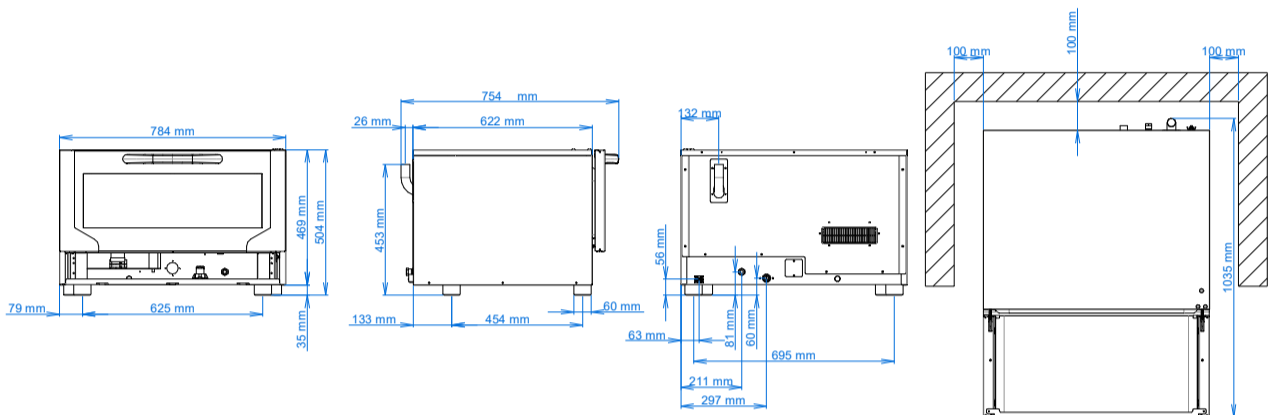

## ELECTRIC CONVECTION OVEN WITH DIRECT STEAM

Use: Gastronomy



### DIMENSIONAL FEATURES

Oven dimensions (WxDxH mm)	784	754	504
Oven weight (kg)	44		
Distance between rack rails (mm)	70		

### ELECTRICAL FEATURES

Power supply (kW)	3,7
Frequency (Hz)	50 (60 on demand)
Voltage (Volt)	AC 220/230
N° of motors	1 Bidirectional
Boiler	/
Protection against water	IPX3

### FUNCTIONAL FEATURES

Power	Electricity
Capacity	N° 3 trays/grids 1/1 GN
Type of cooking	Ventilated
Steam	Direct steam controlled by knob (5 levels)
Cooking chamber	AISI 304 Stainless steel
Temperature	100 - 260 °C
Temperature control	Thermostat
Control panel	Electromechanic - Lower side
N° of programs	/
Programmable cooking steps	/
Pre-heating temperature	/
Pre-heating function	/
Door	Tilt door Ventilated Inspectionable glass
Modularity	Available

### EQUIPMENT

Cardboard box dimensions (WxDxH mm)	805	830	670
Lateral supports	1 right + 1 left		
Cable	Single-phase [3G 1,5] - L=1600 mm		