

## LiberoPro LiberoPro Point for 2 1PH Units

ITEM # \_\_\_\_\_

MODEL # \_\_\_\_\_

NAME # \_\_\_\_\_

SIS # \_\_\_\_\_

AIA # \_\_\_\_\_

**351080 (E2VVADBQZA)**

LiberoPro Point Mobile Counter, suitable for 2 LiberoPro Line appliances with four 1-phase sockets

### Short Form Specification

**Item No.** \_\_\_\_\_

Plug in mobile cooking station in heavy duty AISI 304 stainless steel. Can be combined with up to two LiberoPro table top units 1PHASE (Plug Type Schuko): flat induction hobs, induction wok, induction griddle. Plate holder shelf coupled with tempered glass and lighting for a better visibility from guest side. Automatic ventilation adjustment according to cooking intensity thanks to LiberoPro Duo function. Integrated air filtration system - LiberoPro Fresh - to absorb efficiently grease particles and bad odours in the working area. It is a 2-stage system with stainless steel and ceramic activated carbon filters easy to remove for cleaning operations. For additional storage space, up to two optional neutral 30 lt drawers are available.

Counter Plug Type : IEC/EN 60309-1/2 - 32 Amps. Mounted on 4 swivelling wheels (2 with brakes).

### Main Features

- Can be combined with up to two tabletop appliances LiberoPro 1PHASE (Plug Type Schuko): flat induction hobs, induction wok, induction griddle.
- Compact, lightweight and easy to move.
- Plate holder shelf coupled with tempered glass and lighting for a better visibility from guest side.
- Designed for LiberoPro Duo function for automatic regulation of fan speed according to cooking intensity. Can be activated exclusively with LiberoPro stand alone units.
- LiberoPro Fresh is a low noise air filtration system to absorb efficiently grease particles and bad odours in the working area. It is a 2-stage filtering system with stainless steel fat filters and ceramic activated carbon ones.
- 30 lt neutral drawer - accepting N° 1 GN1/1 - is available as optional accessory.
- Through the user interface with soft touch buttons the operator can:
  - vary the 4 fan speed;
  - switch on the LED lighting system of the cooking area;
  - display indications on maintenance operations (e.g. on filters) or any anomalous operating conditions.

### Construction

- Heavy duty AISI 304 Stainless steel construction.
- Mounted on 4 swivelling wheels with brakes on the 2 front wheels (on the operator side).
- Frontal panel in AISI 304 can be customized requiring a special execution.
- Grease and odours filters are easily accessible and removable from operator's side for efficient maintenance without any tool.
- Side support frames each holding n.2 GN 1/9 containers and n.1 tools holder. All included in the standard delivery and easily removable for better cleanability.
- Plug type: IEC/EN 60309-1/2 - 32 amps.
- IPx4 water protection.

### Included Accessories

- 2 of Carbon filter for Mobile Counter PNC 650190
- 2 of Labyrinth grease filter with stainless steel grid for Mobile Counter PNC 650191
- 1 of Support frame for containers including 2 x 1/9 GN trays and 1 kitchen tool holder for Mobile Counter, left side PNC 650192
- 1 of Support frame for containers including 2 x 1/9 GN trays and 1 kitchen tool holder for Mobile Counter, right side PNC 650193

### Optional Accessories

- Tilting side shelf for Mobile Counter PNC 650005

**APPROVAL:** \_\_\_\_\_

- Neutral drawer for Mobile Counter PNC 650189
- Carbon filter for Mobile Counter PNC 650190
- Labyrinth grease filter with stainless steel grid for Mobile Counter PNC 650191
- Support frame for containers including 2 x 1/9 GN trays and 1 kitchen tool holder for Mobile Counter, left side PNC 650192
- Support frame for containers including 2 x 1/9 GN trays and 1 kitchen tool holder for Mobile Counter, right side PNC 650193
- Kitchen tool holder to be inserted into support frame for Mobile Counter PNC 650194
- Side paper towel support PNC 650195

Front

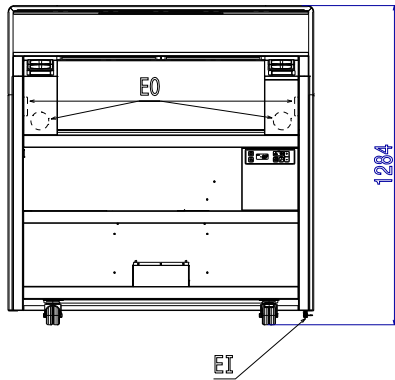

Side

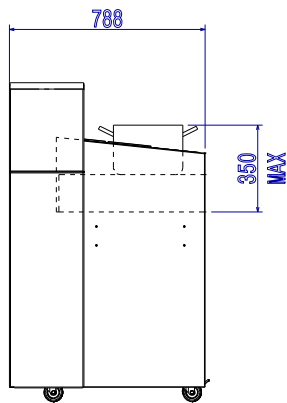

EI = Electrical inlet (power)  
EO = Electrical Outlet

Top

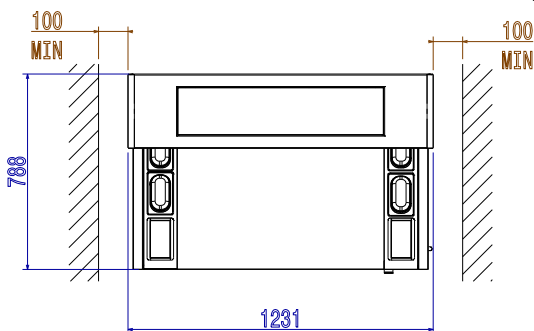

### Electric

Supply voltage:	380-415 V/3N ph/50/60 Hz
351080 (E2VVADBQZA)	
Electrical power max.:	14.5 kW
Plug type:	IEC/EN 60309-1/2

### Key Information:

External dimensions, Width:	1231 mm
External dimensions, Height:	1284 mm
External dimensions, Depth:	788 mm
Net weight:	155 kg

Frontal power sockets available for Plug-in Units:	4 x 1 Phase Plugs (Plug Type Schuko)
--	--------------------------------------

### Air Emission:

Air Flow Rate	710 m <sup>3</sup> / hour
---------------	---------------------------