

Item
Model
ProjectName



660031

FEATURES

- Sturdy construction in 304 AISI stainless steel and mounted on height-adjustable feet.
- Washing well and all external panelling in 304 AISI stainless steel; support top in stainless steel with work area in non-toxic material suitable for use with food.
- Internal components made entirely from 304 AISI stainless steel and/or non-corrosive material for maximum hygiene.

Fixed well

The range consists of two models with a fixed well designed for the efficient and safe treatment of vegetables in the commercial kitchen. Those appliances have been constructed on the basis of rigorous technical principles to guarantee functionality, long term reliability and efficient running costs.

- Perforated stainless steel base filter which is easily removeable to allow inspection of the well bottom; the well has an overflow with suitable filter in 304 AISI stainless steel.
- The dimensions of the appliance are in line with the rest of the preparation equipment range.
- The washing well is shaped to achieve an efficient water vortex for a quick and thorough washing of the vegetables.

Vegetable washer



DITO**Electrolux**

- Control panel on the front panel of the appliance for easy and quick operation; the panel consists of a limited number of controls: ON/OFF switch and a water inlet to the well, operating cycle and well drainage switch. The panel also includes a knob for regulating the inlet and pressure of the wash water, variable from minimum to maximum; regulation is via a "soft-action" ball valve.

- Inclined well bottom to allow automatic cleaning of the bottom of the well.
- Drainage solenoid valve for rapid opening and closing to guarantee easy and efficient well drainage.
- Water inlet solenoid valve for rapid fill of the well.

Specifications

MODEL	LV200 660031	LV300 660033
External dimensions - mm		
width	1200	1500
depth	700	900
height	850	850
Usable well capacity - lt	200	300
Loading capacity - kg.		
light vegetables	8	10
heavy vegetables	30	40
Power - kW		
total power	1.1	1.1
Net weight - kg.	105	150

Optional accessories

CODE	DESCRIPTION	LV200 660031	LV300 660033
661040	MOBILE TANK WITH FALSE BOTTOM - 140 L	✓	✓



DITO**Electrolux**

Installation drawings

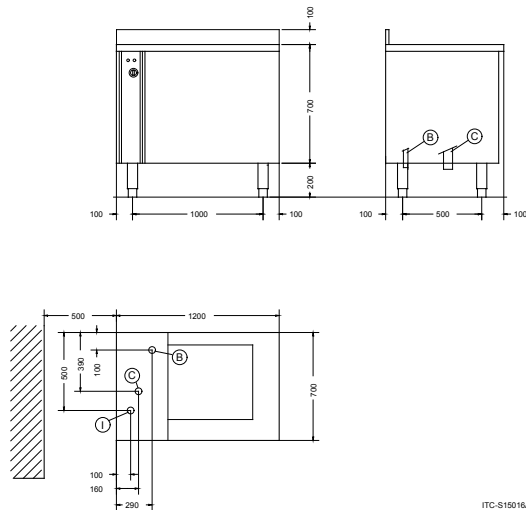
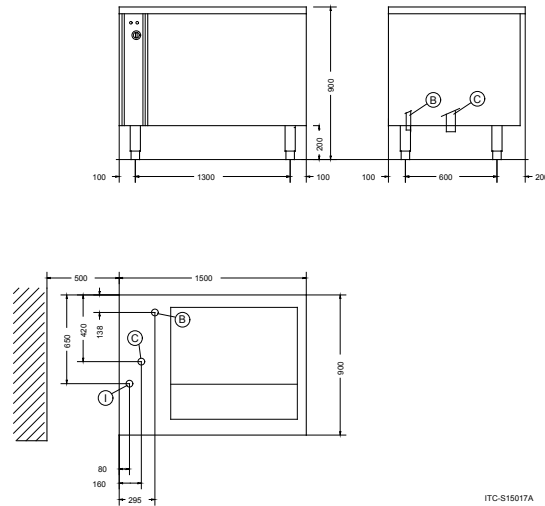
660031**660033****MODEL****LV200
660031****LV300
660033**

B - Cold water inlet

1"

1"

C - Water drain

2"

2"

I - Electrical connection

400 V, 3N, 50

400 V, 3N, 50

The manufacturer reserves the right to modify and make improvements to the products without giving prior warning. Dimensions, illustrations, technical data, weights, etc. are given as an indication only.



www.dito-electrolux.com

Vegetable washer

AGAC010

