

# MKF 1021 S

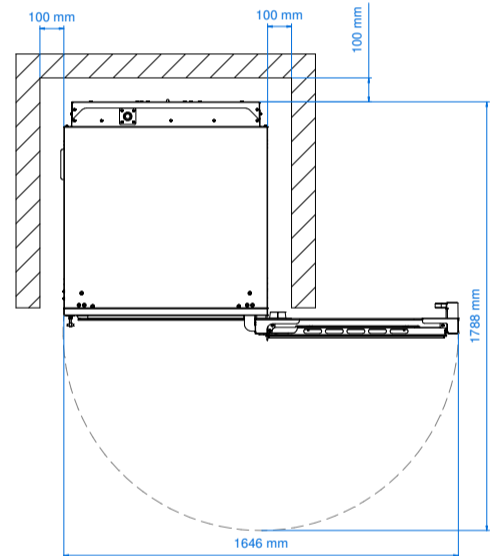

## Electric combi oven 10 trays 2/1 GN with electromechanic panel

With a three-knob electromechanical panel, the new MKF 1021 S oven allows high-performance management for achieving the best results in the kitchen with excellent, even cooking and fast times that result in reduced consumption, a characteristic that is the distinguishing mark of the entire MILLENNIAL line.

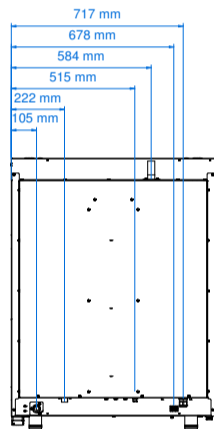
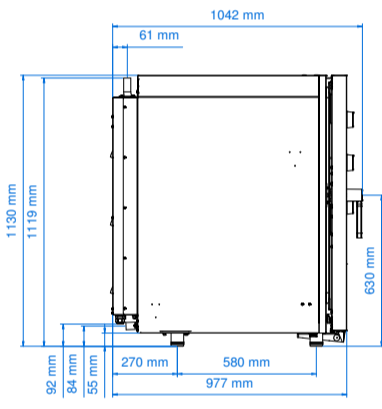
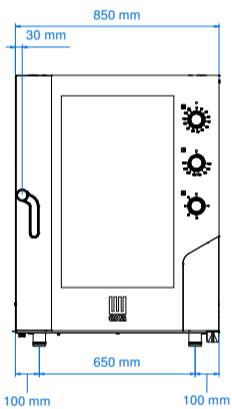

### Plus

Available on request at the order Voltage (V) : AC 220/230 3 PH  
Left side opening door \*  
 Adjustable door hinges

### Equipment

Cardboard box dimensions with pallet (WxDxH mm) 910 x 1090 x 1295  
 Lateral supports 1 right + 1 left  
 Manual washing predisposition  
 Condensate collection bowl, with drain on door  
 Hinge with door locking for openings adjusted at 60°, 90°, 120°, 180°

### Dimensional features

Dimensions (WxDxH mm) 850 x 1041 x 1130  
 Weight (kg) 140,4  
 Distance between rack rails (mm) 80

### Optionals

Available in the dedicated section

### Electrical features

Power supply (kW)	27,5
Frequency (Hz)	50/60
Voltage (V)	AC 380/400 3N
N° motors	3 bidirectionals
Boiler (kW)	/
Protection against water	IPX4

### Functional features

Power	Electricity
Capacity	N° 10 trays/grids 2/1 GN
Type of cooking	Ventilated
Steam	Direct steam controlled by knob (5 levels)
Cooking chamber	AISI 304 stainless steel
Temperature	100 - 270 °C
Temperature control	Thermostat
Control panel	Electromechanic - right side
N° programs	/
Programmable cooking steps	/
Pre-heating temperature	/
Pre-heating function	/
Door	Right side opening Ventilated Inspectionable glass
Modularity	Yes
Feet	Adjustable