

MKF 1664 S

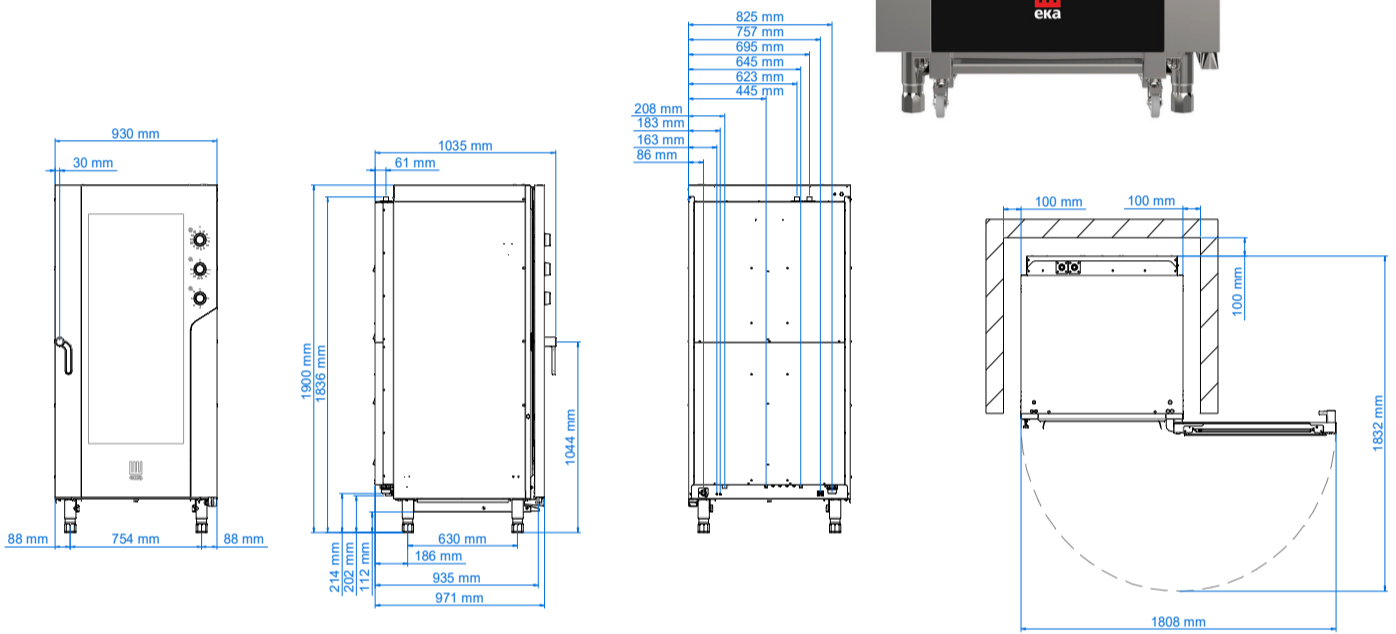

Electric combi oven 16 trays 600 x 400 mm
with electromechanic panel



Dimensional features

Dimensions (WxDxH mm)	930 x 1035 x 1900
Weight (kg)	247,2
Distance between rack rails (mm)	80

Electrical features

Power supply (kW)	31
Frequency (Hz)	50 (60 on demand)
Voltage (V)	AC 380/400 3N
N° motors	4 bidirectionals
Boiler (kW)	/
Protection against water	IPX4

Functional features

Power	Electricity
Capacity	16 trays/grids 600 x 400 mm
Type of cooking	Ventilated
Steam	Direct steam controlled by knob (5 levels)
Cooking chamber	AISI 304 stainless steel
Temperature	100 - 270 °C
Temperature control	Thermostat
Control panel	Electromechanic - right side
N° programs	/
Programmable cooking steps	/
Pre-heating temperature	/
Pre-heating function	/
Door	Right side opening Ventilated Inspectionable glass
Feet	Adjustable

Optionals

Condensation hood	MKCC 1620 S
Trolleys	EKCR 16TC ERCR 1664
Other accessories	Available in the dedicated section

Equipment

Cardboard box dimensions with pallet (WxDxH mm)	1146 x 1260 x 2090 mm
Manual washing predisposition	
Hinge with door locking for openings adjusted at 60°, 90°, 120°, 180°	
Trolley with removable handle and braked wheels cod. EKCR 16TC	

Plus

Available on request at the order	Voltage (V) : AC 220/230 3 PH Left side opening door
Adjustable door hinges	