

MKF 511 G BM

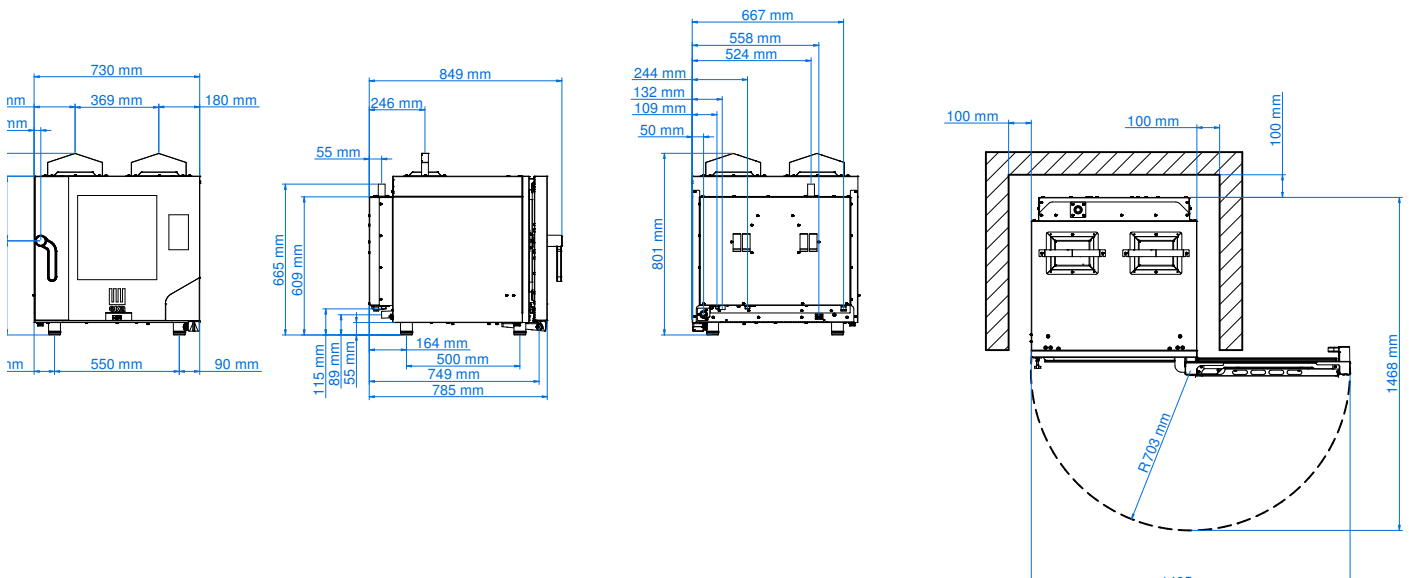

Gas combi oven 5 trays 1/1 GN
with digital touch panel with
BLACK MASK technology



Dimensional features

Dimensions (WxDxH mm)	730 x 849 x 801
Weight (kg)	89
Distance between rack rails (mm)	68

Electrical features

Thermal supply (kW)	9,3
Frequency (Hz)	50/60
Voltage (V)	AC 220/230
N° motors	1 bidirectional
Boiler (kW)	/
Protection against water	IPX3

Functional features

Power	Multigas (tested for natural gas)
Capacity	N° 5 trays/grids 1/1 GN
Type of cooking	Semistatic + ventilated
Steam	Direct steam controlled by touch screen (10 levels)
Cooking chamber	AISI 304 stainless steel
Temperature	30 - 260 °C
Temperature control	Digital probe thermometer
Control panel	Black mask electronic control
N° programs	100
Programmable cooking steps	10
Pre-heating temperature	180 °C
Pre-heating function	Programmable
Door	Right side opening Ventilated Inspectionable glass
Feet	Adjustable

Optionals

Kit for overlapping ovens	MKSST 511
Tables	MKTS 11
Holding cabinet	MKM 1211
Other accessories	Available in the dedicated section

Equipment

Cardboard box dimensions with pallet (WxDxH mm)	788 x 903 x 866 mm
Lateral supports	1 right + 1 left
Cable	Single-phase [3G 1,5]-L=1600 mm
USB port	
Core probe predisposition	
Automatic washing system predisposition	
Condensate collection bowl, with drain on door	
Hinge with door locking for openings adjusted at 60°, 90°, 120°, 180°	
Nozzle for LPG	

Plus

Patented fan guard system Airflowlogic™	
Patented system for direct steam Humilogic™	
Available on request at the order	Left side opening door
Humidity management software	
Programmable oven start	
N° 40 recipes stored	
HACCP system	
Adjustable door hinges	
Regulation 2016/426/UE	