

Item
Model
ProjectName



LMP600BF

The pastry roller has an important role in catering or restaurant kitchens, as it helps with the lining of pastry, rolling of dough and puff pastry work. The LMP600BF is used in restaurants and big production kitchens. It can work with any type of dough and can allow for a wide range of thicknesses and may be equipped with cutting module for croissants.

603538

FEATURES

- The LMP600BF is a floor standing belt dough sheeter mounted on wheels.
- Working width of 600 mm and two working belts 1300 mm in length.
- The rolling direction may be inverted by the movement of a joystick.
- 2 speed model.
- The cylinders may be regulated for sheets ranging from 0,1 to 34 mm in thickness.
- Rollers: 71,5 mm Ø in chromium plated steel. The accessibility of the parts in contact with the pastry/dough makes cleaning easier. The smooth surfaces are white-paint finished.
- The upper and lower roller scrapers may be easily removed for cleaning.
- The slides can be raised to save space.
- Cutting module for croissants 130x140 mm available as accessory.

Dough sheeters



DITO

Electrolux

- Each safety grating is hinged on the structure and is equipped with a safety micro-switch which helps to avoid injury. When the gratings raise over a particular level, the motor stops.
- Remote foot pedal to change rolling direction (available as accessory).
- Flour container fixed on the top of the machine.

- General electrical protection by fuses.
- Motor protected by a circuit breaker.
- The belts can be removed and are washable.
- Ergonomic controls situated very close together and are designed to suit natural movements.
- Emergency stop button with lock and manual re-start.

Specifications

MODEL	LMP600BF 603538
External dimensions - mm	
width	3050
depth	1020
height	1290
Power - kW	
installed-electric	1.1
Net weight - kg.	240
Supply voltage	380...415 V, 3, 50

Optional accessories

CODE	DESCRIPTION	
653601	CUTTING MOD(CROISS)TRIANG.130X140-LMP600	✓
653600	PEDAL TO CHANGE ROLLING DIRECT.-SHEETERS	✓



DITO

Electrolux

Installation drawings

603538

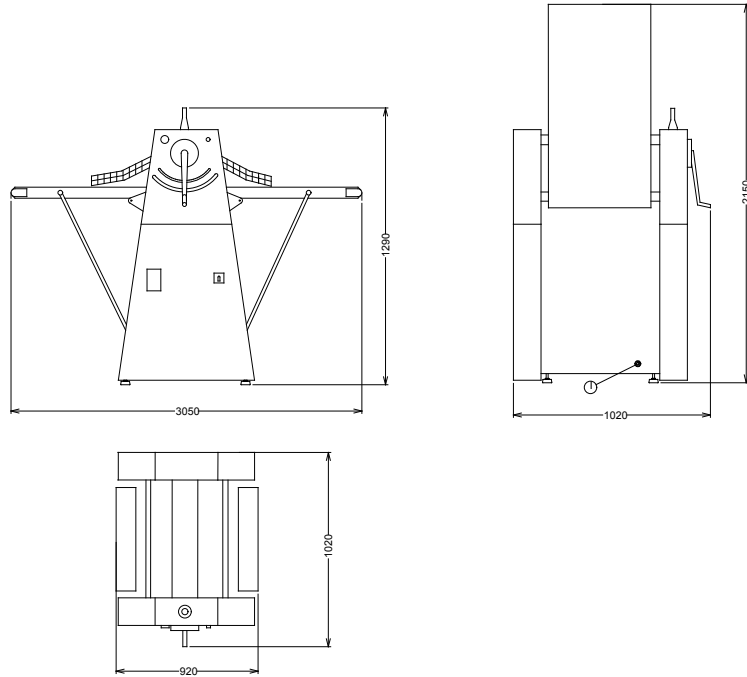

MODEL

I - Electrical connection

LMP600BF
603538

380...415 V, 3, 50

The manufacturer reserves the right to modify and make improvements to the products without giving prior warning. Dimensions, illustrations, technical data, weights, etc. are given as an indication only.



www.dito-electrolux.com

Dough sheeters



AIE010