

MKF 664 S

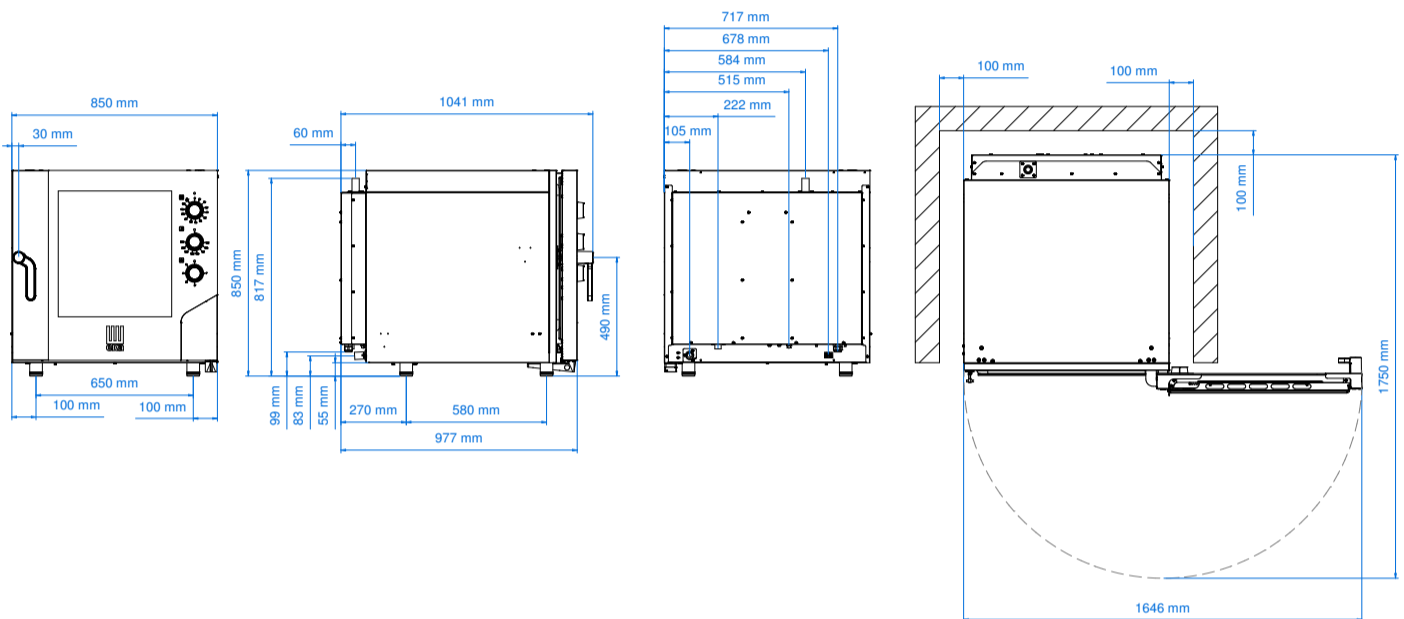

Electric combi oven 6 trays 600 x 400 mm
with electromechanic panel



Dimensional features

Dimensions (WxDxH mm)	850 x 1041 x 850
Weight (kg)	108,2
Distance between rack rails (mm)	80

Electrical features

Power supply (kW)	10,4
Frequency (Hz)	50 (60 on demand)
Voltage (V)	AC 380/400 3N
N° motors	2 bidirectionals
Boiler (kW)	/
Protection against water	IPX4

Functional features

Power	Electricity
Capacity	6 trays/grids 600 x 400 mm
Type of cooking	Ventilated
Steam	Direct steam controlled by knob (5 levels)
Cooking chamber	AISI 304 stainless steel
Temperature	100 - 270 °C
Temperature control	Thermostat
Control panel	Electromechanic - right side
N° programs	/
Programmable cooking steps	/
Pre-heating temperature	/
Pre-heating function	/
Door	Right side opening Ventilated Inspectionable glass
Modularity	Yes
Feet	Adjustable

Optionals

Condensation hood	MKKC 610 S
Kit for overlapping ovens	MKS 64 MKST 664
Tables	MKTS 64 MKT 64 D
Proofer	MKL 1064 S
Other accessories	Available in the dedicated section

Equipment

Cardboard box dimensions with pallet (WxDxH mm)	910 x 1090 x 1015 mm
Lateral supports	1 right + 1 left
Cable	Three-phase+neutral [5G 2,5]-L=1600 mm
Manual washing predisposition	
Condensate collection bowl, with drain on door	
Hinge with door locking for openings adjusted at 60°, 90°, 120°, 180°	

Plus

Available on request at the order	Voltage (V) : AC 220/230 3 PH Left side opening door
Adjustable door hinges	