

Fast and  
reliable

TDR 5 Manual

**The Turbo Deli Rotisserie is the fastest original rotisserie in the industry. The TDR's cavity is fed with fresh air, roasting a rotisserie chicken as it is meant to be: crispy and delicious while maintaining an attractive appearance for hours.**

The TDR pushes the air throughout the cavity, resulting in an improved heat transfer on the products. It consumes less electricity during the preparation process. Add to this the improved cooking time and you have the most energy efficient rotisserie and a high output.

The double glass doors create a striking, large display section that maximises your products' visual appeal to customers! It also offers perfect insulation with contact temperatures below 70°C.



## Features TDR 5 Manual

### Top features

- Controls with manual settings
- Easy to operate - set time, temperature and start the rotisserie
- Efficient heat transfer reduces energy consumption
- Endless possibilities: poultry (parts), pork roast, ribs, lamb, roast beef, pork belly, meat loaf, porchetta and other proteins

### Standard characteristics

- 5 Meat fork, V-spit, basket or rack positions
- Rotor for up to 20 chickens (1,2 kg)
- Range of accessories available for preparation of chicken, chicken parts, ribs, etc.

### Accessories

- Meat forks (included)
- Multi-purpose baskets
- Insert for baskets
- V-spits
- Stand on castors

### Optional

- Stacked unit 5 + 5 M
- Flexible positioning with ventless hood
- Door handle set for pass through operation
- Also available in combination with a 2 level self-serve heated display - Space Saver



Manual controls



Ventless hood (optional)



5 M with self-serve heated display



Also available: Stacked TDR 5 + 5 M

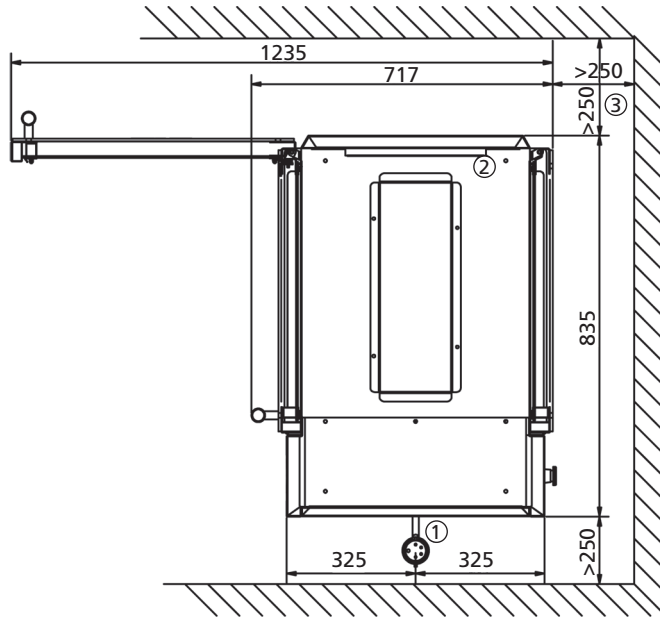

## TDR 5 Manual

- 1 Power cable, 2.2 m
- 2 Exhaust opening
- 3 Space to the wall
- 4 Location for socket

### Dimensions TDR 5

|                  |         |
|------------------|---------|
| Width            | 835 mm  |
| Depth            | 717 mm  |
| Depth with hood  | 853 mm  |
| Height           | 910 mm  |
| Height on stand  | 1725 mm |
| Height with hood | 1245 mm |

### Technical data TDR 5

|              |               |
|--------------|---------------|
| Net weight   | 130 kg        |
| Gross weight | 152 kg        |
| Voltage      | 3N~ 400/230 V |
| Frequency    | 50/60 Hz      |
| Power        | 6.6 kW        |

### Dimensions TDR 5+5

|                  |         |
|------------------|---------|
| Width            | 835 mm  |
| Depth            | 717 mm  |
| Depth with hood  | 853 mm  |
| Height           | 1790 mm |
| Height with hood | 2124 mm |

### Technical data TDR 5+5

|              |               |
|--------------|---------------|
| Net weight   | 266 kg        |
| Gross weight | 306 kg        |
| Voltage      | 3N~ 400/230 V |
| Frequency    | 50/60 Hz      |
| Power        | 13.2 kW       |

Specifications and technical data are subject to amendment without prior notice.

These are basic drawings. For more detailed technical information, please refer to the installation manual at [www.frijado.com](http://www.frijado.com).

