

| |
|-------------|
| Item |
| Model |
| ProjectName |



CPX + Optional Table

CPX

The CPX is an electric bread slicer useful in all high volume catering establishments or for company and commercial kitchens. The CPX bread slicer is well suited to the kitchens of schools and colleges, with table or self-service, truck stops, company canteens, cafeterias, etc.

FEATURES

- Safety, in both operation and cleaning. The CPX is fitted with an original safety device so the user does not touch the blade, especially when cleaning. The blade is immobilised and covered when the bread evacuation door is raised.
- Cost saving, as bread sliced in this way costs less than individual buns or loaves.

- Hygienic, as the bread does not have to be handled in order to be cut; and the machine may be fitted on a table or on a special stand.
- Long loaves (400 g French loaves, sticks and baguettes) may be cut into slices between 8 and 60 mm thick, depending on the setting.
- The bread is simply inserted in a vertical spout and is cut automatically as soon as the machine is started.

Bread slicers



DITO

Electrolux

- Output: approximately 130 to 260 slices/minute (2 baguettes). Maximum cross section of the bread: 110 - 175 mm.
- Eliminates waste thanks to its high speed of operation, the bread may be cut as required.
- Saves time because the bread slicer operates three to six times quicker

than slicing by hand, with better quality results.

- Touch button control panel improves the ergonomics and the reliability against the humidity or water jets.
- Pulse button.
- Start/Stop push button.
- The motor stops immediately when the safety guard is opened.

Specifications

| MODEL | CPXF215 603265 |
|--------------------------|-------------------|
| External dimensions - mm | |
| width | 472 |
| depth | 418 |
| height | 857 |
| Power - kW | |
| installed-electric | 0.37 |
| Net weight - kg. | 31 |
| Supply voltage | 230 V, 1N, 50 |

Optional accessories

| CODE | DESCRIPTION | |
|--------|---------------------------------------|---|
| 653180 | TABLE+SHELF+GN 1/1 POLYCARBONATE TRAY | ✓ |



DITO

Electrolux

Installation drawings

603265

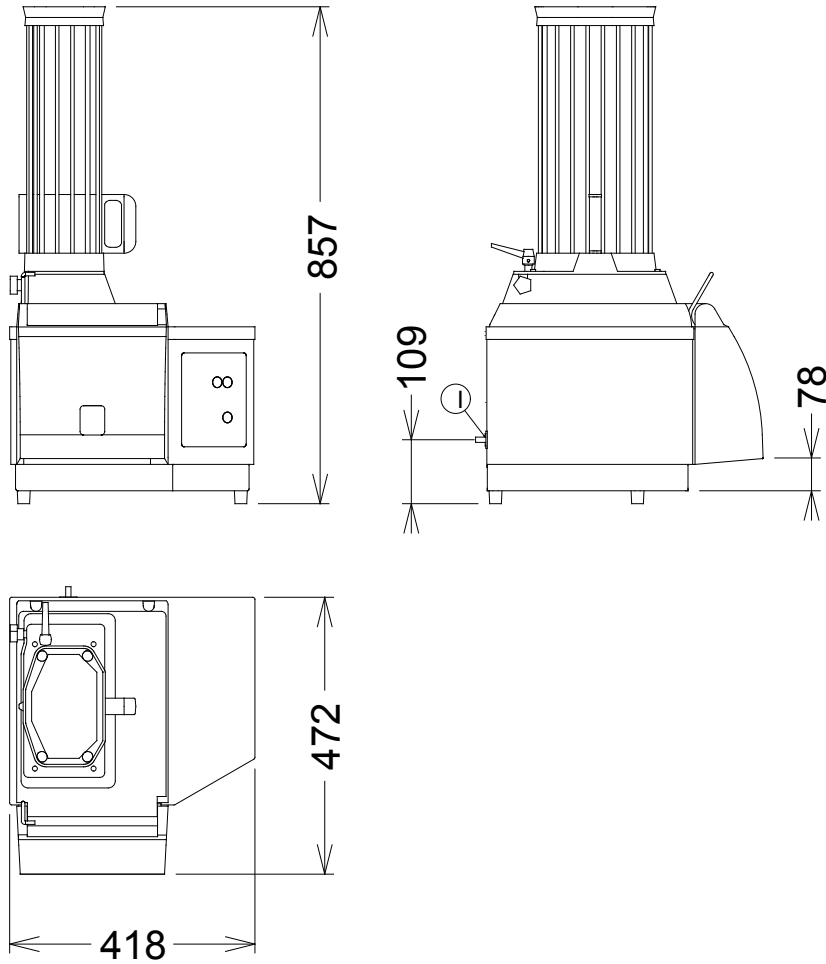

MODEL

I - Electrical connection

CPXF215
603265

230 V, 1N, 50



Bread slicers

The manufacturer reserves the right to modify and make improvements to the products without giving prior warning. Dimensions, illustrations, technical data, weights, etc. are given as an indication only.



www.dito-electrolux.com

