

EKF 523 N UD

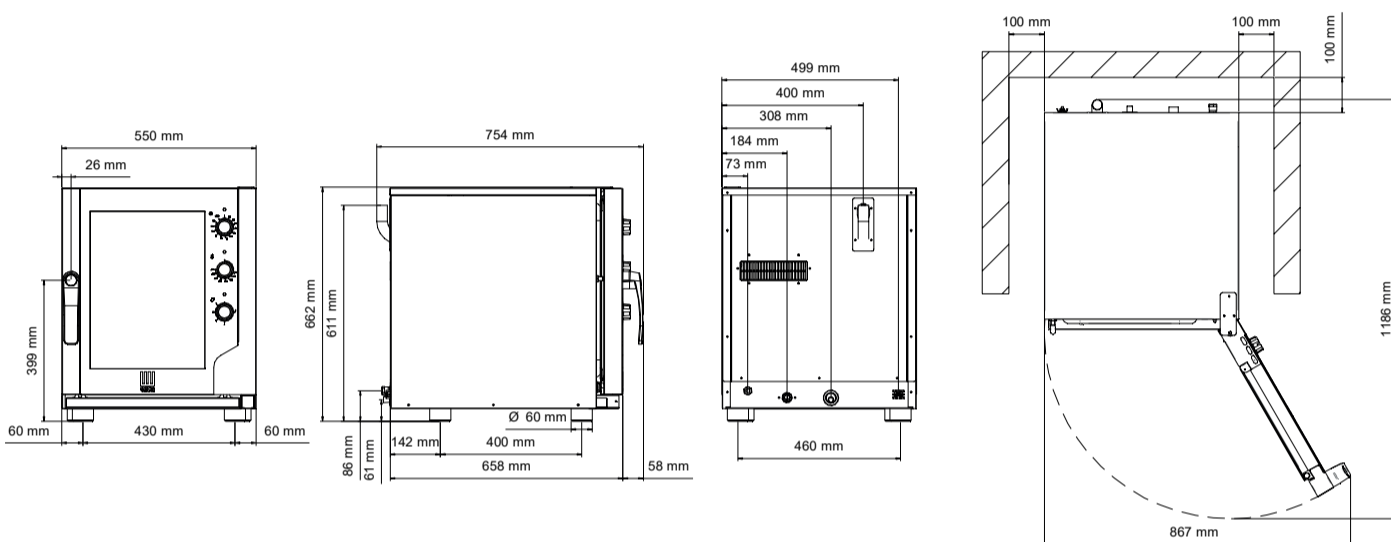

ELECTRIC COMBI OVEN

The latest 5 trays 2/3 GN with just 55cm width size , EKF523NUD establishes a new benchmark level for cafes and convenience store thanks to its compact size, a truly smart design along with easy adjustable commands, motor's reverse rotation, steam injection, available inner drain.



DIMENSIONAL FEATURES

Oven dimensions (WxDxH mm)	550	754	662
Oven weight (kg)	40		
Distance between rack rails (mm)	80		

ELECTRICAL FEATURES

Power supply (kW)	3,2
Frequency (Hz)	50 (60 on request)
Voltage (Volt)	AC 220/230
N° of motors	1 Bidirectional
Boiler	/
Protection against water	IPX4

FUNCTIONAL FEATURES

Power	Electricity
Capacity	N° 5 Trays / grids 2/3 GN (354x325 mm)
Type of cooking	Ventilated
Steam	Direct controlled by 5-position knob selector
Cooking chamber	AISI 304 Stainless Steel
Temperature	100 - 270 °C
Temperature control	Thermostat
Control panel	Electromechanic-right side
N° of programs	/
Programmable cooking steps	/
Pre-heating temperature	/
Pre-heating function	/
Door	Right hinged only
Modularity	/

EQUIPMENT

Cardboard box dimensions with pallet (WxDxH mm)	599	784	735
Lateral supports	1 right + 1 left		
Cable	Single-Phase [3G 1,5] - L=1600 mm		
Manual washing set up			